

目录Contents

1. 使用说明书 INSTRUCTION MANUAL

1. 1. 安全事项和注意事项 Safety instruction and notes for procedure	1-7
1. 2. 安装台的组装Assembling the machine rest board	8
1. 3. 缝纫机的安装 Sewing machine installation	8
1. 4. 皮带轮护盖的安装Installing the belt cover	8
1. 5. 缝纫机的旋转方向 Operating direction of machine pulley	8
1. 6. 关于供油Lubrication	9
1. 7. 给HR装置供油Silicone oil for H.R.device	10
1. 8. 穿线的方法Threading	11-12
1. 9. 压脚压力的调节Adjusting presser foot pressure	13
1. 10. 差动比的调节Adjusting the differential feed ratio	13
1. 11. 针脚长度的调节Adjusting stitch length	13
1. 12. 线状态的调节Adjusting the thread tension	14
1. 13. 缝纫机的清扫Cleaning the machine	14
1. 14. 机针的更换Replacing the needle	15
1. 15. 机油的更换Oil replacement	15
1. 16. 排油的方法To drain the oil	15
1. 17. 油泵滤油网的检查与清扫Checking and cleaning the oil filter	16
1. 18. 调整基准数值/针号对照表/标准用针 Adjustment dimensions/Comparison table for equivalent sizes/standard needle	17
1. 19. 子型号规格表Subclass specification	18

2. 零件手册 PARTS LIST

2. 1. 机壳结构(1) Machine bed frame (1)	20-21
2. 2. 机壳结构(2) Machine bed frame (2)	22-23
2. 3. 机壳结构(3) Machine bed frame (3)	24-25
2. 4. 下轴传动机构 Crank shaft drive mechanism	26-27
2. 5. 上轴传动机构 Arm shaft drive mechanism	28-29
2. 6. 针杆机构 Needle bar mechanism	30-31
2. 7. 保针机构 Needle guard mechanism	32-33
2. 8. 弯针机构 Looper drive mechanism	34-35
2. 9. 送布机构 Feeder mechanism	36-38
2. 10. 差动调节机构 Differential feed mechanism	39-40
2. 11. 压脚机构 Presser foot mechanism	41-42
2. 12. 绷针机构 Spreader mechanism	43-44
2. 13. 挺线及夹线机构 Thread tension mechanism	45-46
2. 14. 挑线机构 Needle&spreader thread handling	47-48
2. 15. 打线凸轮机构 Looper thread handling	49-50
2. 16. 润滑机构(1) Lubrication mechanism(1)	51-52
2. 17. 润滑机构(2) Lubrication mechanism(2)	53-54
2. 18. 硅油盒机构 HR device	55-56
2. 19. 线架 Thread stand	57-58
2. 20. 台板及附件 Parts for semi-submerged installation	59-60
2. 21. 卷边专用件 Folder Asm	61-62
2. 22. 直驱电机结构Esdd Motor Components	63-64
2. 23. 针位互换清单Gauge Parts List	65

1.使用说明书

INSTRUCTION MANUAL

1、前言 Introduction

- 该书是为了安全使用本产品的使用说明书。

This is the instruction manual that describes how to use this product safely.

- 在使用该产品之前,务必阅读此书,在充分理解掌握缝纫机的操作、检查、调整、维修等方法之后,再进行使用。

Read this instruction manual and learn very carefully how to operate, adjust and service this sewing machine before beginning any of the procedures.

- 工业用缝纫机是在缝纫作业中,操作者距机针等运动着的缝纫机部件近距离进行操作的。

所以时常有接触缝纫机运动部件的危险性,这点应充分认识。

因此,为了确保安全,需要本公司提供安全的产品,使用者正确安全的操作。对于顾客也有一些必要的安全对策和要
求。缝纫机使用的有关人员务必熟读本书与驱动装置的使用说明书,在实施必要的安全对策之后,再充分使用缝纫机。

You should realize first that there is always the risk of contacting moving parts, such as needles because you have to work at point-blank range to them when you are operating industrial sewing machines.

For safety it is essential that we supply safe products and you use them correctly and safely.

There may be some safety measures that you yourself must take.

Therefore, you should read and understand very carefully this instruction manual together with that of the driving equipment and take necessary safety measures in order to use this machine efficiently and effectively.

2、安全措施 Safety precautions

①用途·目的 Applications, purpose

本公司的工业用缝纫机,是以提高服装业的质量和生产率为目的而研究开发的商品。因此除以上用途以外,请绝对不要使用。

Our industrial sewing machines have been developed in order to increase quality and/or production in the sewing industry. Accordingly never use our products for other than intended use described above.

②使用环境 Circumstances

本公司的工业用缝纫机,根据使用的环境,有可能给缝纫机的寿命、性能及安全带来不良影响。

The environment in which our industrial sewing machines are used may seriously affect their lives, functions, performance and/or safety. For safety, do not use the machine under the circumstances below.

1. 在靠近高频焊接机等产生干扰的机器设备旁边。

Do not use the machine near objects which make noise such as a high-frequency welder, etc.

2. 产生药品蒸气气氛的地方,及受药品飞溅等地方使用或保管。

Do not use or store the machine in the air which has vapor from chemicals, or do not expose the device to chemicals.

3. 屋外、高温高湿、直接曝曬阳光的地方。

Do not leave the machine outside, in high temperatures or the direct sun.

4. 周围的温度、湿度很大,会给缝纫机带来坏影响的地方。

Do not use the machine in the places of high ambient temperature and humidity that seriously affects sewing machines.

5. 额定电压常超过±10%以上的电压变动较厉害的地方。

Do not use the machine on the condition that the voltage fluctuation range is more than ±10% of the rated voltage.

6. 电源容量无法确保控制马达规格上所需要的容量时。

Do not use the machine in the place where the supply voltage specified for the control motor cannot be properly obtained.

③安全措施 Safety measures

(1) 进行维修保养、检验时的安全保护 Safety precautions when you perform maintenance on the machine.

在对缝纫机进行检查、修理、清扫等维护作业时,请关掉电源开关,将电源插销从插座上拔下,并确认踩缝纫机踏板也不会转动之后,再进行操作。但是,有必要接通电源进行作业时,请制定防止缝纫机意外转动或操作者错误而导致危险的安全操作准则,并遵守一切安全防护规则。

Always turn off the power, unplug the machine and then make sure that the machine does not run by pressing the treadle before performing any maintenance, such as checking, repairing, cleaning, etc. However, if you need to perform these procedures with the power on, to prevent accidents due to the unexpected start of the machine and users misoperation, establish your own procedures for safety and follow them.

在进行以下作业时,务必关掉电源开关,将电源插销从插座上拔下之后进行。

Always turn off the power and unplug the machine before performing the procedures shown below.

- 加油 Lubrication
 - 穿线 Threading
 - 打扫缝纫机 Cleaning
 - 换机针 Replacing the needle
 - 进行供油元件的清扫和更换时。Checking/replacing oil element
 - 更换机油 Replacing the oil
- 在进行以下作业时，请务必关掉电源开关之后进行。Always turn off the power before performing the procedures shown below.
- 调节针脚时 Adjusting the stitch length
 - 调节差动比时 Adjusting the differential feed ratio

(2) 开始运转前的检验事项 Before operating the machine

- 在开始操作运转缝纫机前，先检查缝纫机皮带及缝纫部分，看是否有损伤，功能不良等问题。万一有异常现象时，应立即修理或采取必要的措施。

Check the machine head and unit for any damage and/or faulty function at the start of each day.

If there should be something wrong with the machine, immediately perform repairs and/or other necessary procedures.

- 务必用手触摸来确认针箍是否固定好。Check by hand to see if the needle holder is secured.

※ 请注意针尖有危险。Be careful of the needle point.

- 在使用缝纫机之前，务必确认压脚是否在正确的位置。
(用手轻轻转动手轮，让针尖是否落在压脚的针孔中心)

Before starting the machine, make sure that the presser foot is positioned correctly (turn the machine pulley slowly by hand to see if the needle point is centered in the needle drop hole on the presser foot).

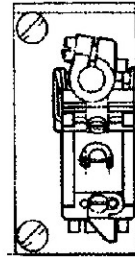

- 务必检查压脚是否牢固的固定好。(使用抬压脚机构抬起压脚，用手前后左右扳动，检查压脚是否有松动)

Check to see if the presser foot is secured (raise the presser foot by the foot lifter and press it by hand front to back and left to right).

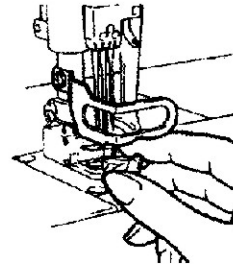

(3) 培训·进修 Training

- 为了防止事故，缝纫头或缝纫系统的操作人员及维修保养专员，应先学会所需知识和有关技能，以其工作的安全。为此，请由客户的管理单位给她们安排培训计划，而实施充分的训练。

To prevent accidents, operators and service/maintenance personnel should have proper knowledge and skills for safe operation.

To ensure so, managers must design and conduct training for these people.

3、各操作过程的注意事项 Notes for each procedure

① 开箱 Unpacking

1. 缝纫机机头在出厂时包装好后装入纸箱运出的。从印刷在纸箱上的标记字样确认上下后，请从上到下按顺序开箱。

The machine is packaged in a cardboard box before shipping. Unpack your machine in orderly sequence while checking them right-Side up by referring to the indications, such as logo, etc printed on the boxes.

2. 把缝纫机机头从缓冲包装材料里拿出时，绝对不要提拿与机针部位或过线器等有关的部件。否则会发生危险或损伤机器。

Never hold the area near the needle and/or thread guide related parts when taking out the machine from the cushion.

3. 在取出缝纫机机头时，请注意重心的位置，小心谨慎的取出。

Take out the machine very carefully while checking the position of the center of the gravity.

4. 开箱用过的纸箱如果以后还用的话，请好好保存放好。

Keep the cardboard box and packing carefully in case secondary transport is needed in the future.

包装材料的处理 Disposal of the packaging

- 包装材料包括木头、纸张、纸箱、VCE纤维。恳请顾客负有责任的将包装材料正确适当的进行处理。

The packaging material of the machine consists of wood, paper, cardboard and VCE fiber. The proper disposal of the packaging is the Responsibility of the customer.

缝纫机废物的处理 Disposal of machine waste

1. 缝纫机的废物, 请客商负责任进行处理。The proper disposal of machine waste is the responsibility of the customer.
2. 制造缝纫机所使用的材料有铁、铝、锌及各种塑料。The materials used on the machines are steel, aluminum, brass and various plastics.
3. 缝纫机的废物应遵照当地环境保护的有关规定进行处理。必要时委托专门的厂家进行处理。

The machine waste is to be disposed of in accordance with the locally valid environmental protection regulations. A specialist should be commissioned if necessary.

※有油污的部件务必遵照当地环境保护的有关规下, 分别进行处理。

The parts contaminated with lubricants should be disposed off separately according to the locally valid environmental protection regulations.

在顾客领地内移动缝纫机 Transport within the customer's premises

- 关于在顾客领地内移动缝纫机, 本制造厂商没有责任。移动时为了避免缝纫机掉落摔坏, 请注意不要倾斜缝纫机是。

The manufacturer assumes no liability for transport within the customer's premises. Care should be taken to transport the machine in an upright position avoiding it from dropping or falling down to the ground when it is moved.

②搬运 Transportation

1. 缝纫机机头的搬运一定要两个人以上进行。另外, 用人直接搬运应只限于搬往缝纫机台或小台车。其他搬运务必使用小台车进行。

The machine should be carried by at least more than two people when it is mounted on the table and/or a hand truck. Be sure to use a hand truck for other transportation.

2. 移动缝纫机机头时, 用右手抓住传动轮, 左手垮在机头里, 扎实牢固的搬起。缝纫机上沾有油污时容易滑脱摔坏, 搬运前请好好擦净机头上的油污。

To carry the machine, hold the machine pulley tightly with your right hand and the machine arm with your left upper arm. If the machine and/or your hands are stained with oil, the machine may be easy to slip out of your hands and fall to the floor. Therefore, wipe off the oil carefully.

3. 在往缝纫机台板上或小台车上搬运时, 请注意不要过分冲击或震动, 以免缝纫机倒斜造危险。

Care should be taken to avoid excessive shock and shake when the machine is mounted on the table and/or transferred using a hand truck. Otherwise the machine may fall down.

4. 如果要第二次运送缝纫机并要包装时, 请一定擦干净机头上的油污。否则搬运时会滑脱摔坏机头或油污使包装材料变质穿底。

Wipe off the oil from the machine before packaging it again for secondary transport. Otherwise the machine may easily slip out of your hands or the bottom of the box may come off while in transit.

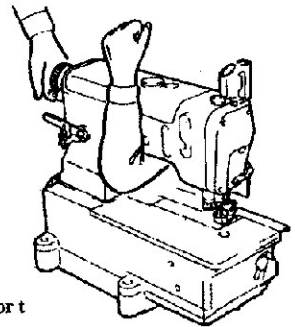

③安装·准备 Installation preparation

缝纫机台板 Machine table

1. 请使用能充分承受缝纫机机头重量及搬运时产生的反作用力的缝纫机台板(台板、铁架)。

Use the machine table (table board, metal legs) that completely carries the machine and is fully resistant to warping while the machine is running.

2. 应充分考虑缝纫机装配部件和操作光线的明亮度, 放置在容易作业的环境中。如果光线不是十分明亮时, 应根据需要安装照明电灯。

Arrange the working environment for easy operation by considering where to place the machine and the brightness around the working area. If the illumination is insufficient, control or change lighting as required.

3. 在运转缝纫机时, 为防止操作者脚踏板时脚滑脱造成事故, 一定要在缝纫机踏板上安装防止滑脱的垫子。

Attach a non-slip pad to the treadle (foot switch). Otherwise the operator may slip off the treadle while running the machine, causing trouble.

4. 在考虑操作者姿势的前提下, 决定台板面的高度(工作时的高度)。

Adjust the height of the table according to a working posture of the operator.

接线 Cables

1. 请牢固的插好缝纫机机头与电机连接线的插头。缝纫机机头与电机用连接线进行连接时, 务必在将电源开关关闭的状态下进行操作。

When connecting the cables between the machine and the motor, be sure to turn off the power and connect each cable connectors securely.

2. 在使用中请不要给连接线过多的力。

Do not strain the cables in use.

3. 请不要过度弯曲连接线。

Do not bend the cables excessively.

4. 接近运动部件(如传动轮、V形皮带等)的连接线, 应最小距离在25mm处进行安装。

When connecting the cables that are close to the moving parts, such as pulley or V belt, keep a distance of 25mm at least between them.

5. 必要时考虑连接位置或加设护罩来保护连接线。

Protect each cable using a cover or adjusting its position if necessary.

6. 固定连接时绝对不要使用订书针, 以免发生漏电或火灾。

Never use staples to fasten the cables, otherwise it causes a short circuit and/or a fire.

电机 Motor

1. 缝纫机电机的安装请遵照电机厂家的使用说明书，正确的进行安装。

Install the machine motor correctly by referring to the instruction manual supplied by the manufacturer.

2. 为了防止被卷入皮带轮的危險，请选用带有防止卷入的缝纫机电机。

Select the machine motor equipped with the pulley cover so that any part of your body etc, is not caught in the belt.

④使用缝纫机油 Handling machine oil

1. 在油盘内没有注入油以前请绝对不要进行运转。

Never start the machine with no oil in the reservoir.

2. 机油进入眼睛会使眼睛发炎，所以在使用时请戴防护眼镜以免机油进入眼睛。

If machine oil gets in your eyes, it may cause eye irritation. To prevent the machine oil from getting in your eyes, wear a pair of protective glasses.

※万一进入眼睛，请用干净水冲洗15分钟再请医生进行治疗。

Should machine oil gets in your eyes, wash them with fresh water for 15 minutes and then go to see a doctor.

3. 机油接触皮肤后，请马上用水和肥皂洗干净。

Avoid skin contact, immediately wash contacted areas completely with water and soap.

4. 绝对不要使机油进入口腔。

Never swallow machine oil.

5. 机油请保管在孩摸不到的地方。

※万一进入口腔，不要硬性呕吐，马上请医生进行治疗。

Keep machine oil out of the reach of children.

※If swallowed, do not induce vomiting immediately go to see a doctor.

6. 废油、废容器的处理方法有必须遵照法令的义务，请根据法令正确处理。如不知道时请与购买部门联系后，正确进行处理。

Dispose of the waste oil and/or containers properly as demanded by law. If you have further questions on its disposal, consult the store or shop at which you purchased it.

7. 为了防止灰尘、水分的混入，使用完后保管机油时请盖紧油箱盖，放在没有阳光直射的荫凉处保管。

After opening the oil container, be sure to seal it to prevent dust and water from getting into the oil and keep it in the dark to avoid direct sunlight.

⑤运转缝纫机前的注意事项 Before starting the machine

缝纫机台板 Machine table

1. 打开电源臆，请确认接线或接头是否有损伤、脱落、松动等外观上的异常。

Before turning the power on, visually check the cables and connectors for defective conditions, such as damage, disconnection and/or loosening.

2. 在打开电源时，请不要将手放在机针附近或传动轮附近。

Never bring your hands close to the needle and/or pulley when turning on the power.

3. 最初开始运转缝纫机时，打开电源确认传动轮的运转方向。缝纫机的正运转从传动轮侧来看是向右旋转。

When the machine is used for the first time, turn on the power and then check the rotating direction of the machine pulley.

The machine pulley should turn clockwise as seen from the machine pulley.

4. 操作缝纫机者应为受过适当训练、充分理解本书及使用说明书的内容之后，再进行操作使用。

Well trained operators should use the machine after studying these precautions and the instruction manual carefully.

5. 最初使用的一个月应降低速度。请使用在最高转速的3/4以下的转速。

Run the machine at the speed less than 3/4 of its maximum for first one month.

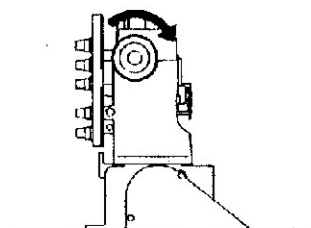

⑥运转缝纫机中的注意事项 Precautions while you are running the machine



- 1.在拆卸下护眼板、护指架、传动轮护罩等安全装置的状态下、请不要运转缝纫机。
Do not run the machine with the safety devices removed,such as eye guard,linger guard,pulley cover,etc.
- 2.缝纫机在运转中是很危险的、绝对不要将手放入机针下。
Never bring your hands under the needle while running the machine.
- 3.使用离合器式电机时关掉电源之后电机仍然会继续旋转一会儿。这时踩缝纫机踏板后缝纫机会运动是很危险的，请特别小心。
A clutch motor keeps on running for a while after the power is turned off.Therefore,be careful even after the power is turned off as the machine could start running by pressing the machine treadle.
- 4.缝纫机在运转中是很危险的，所以绝对不要将手指、头发、衣服接近手轮、V形皮带、电机传动轮、挑线器、针棒。同时，也不要将剪刀、镊子、工具等放在以上部位。
To prevent accidents,never bring any part of your fingers,hair and clothes near the machine pulley,v belt,motor pulley,thread take-up and needle bar.Also never leave scissors,tweezers, tools,etc,around these areas.
- 5.在不使用缝纫机时或者操作者离开缝纫机时，一定要将电源开关关掉。
Always turn off the power while the machine is not used or before leaving the machine table.
- 6.停电时务必将电源关掉。
In the event of a power failure,be sure to turn off the power.
- 7.在操作缝纫机时，请穿着不易被机械卷入的服装。
While operating the machine,wear clothes that cannot be caught in the machine.

⑦维护、检查、修理 Maintenance,Check,Repair

- 1.维护、检查、修理的作业应由受过特别训练的人并在充分理解本书及使用说明书的内容之后，再进行作业。
Well trained people should perform maintenance,check and repair of the machine after studying these precautions and the instruction manual carefully.
- 2.为了维护、检查、修理要将缝纫机机头放倒时，务必将电源开关关掉，把电源插头从插座上拔下，并确认即使踩缝纫机踏板缝纫机也不会转动之后，再进行操作。
If it is necessary to lay the machine backward for maintenance,check and repair,always turn off the power,unplug the machine and press the treadle to make sure that the machine does not operate before beginning any of the procedures.
- 3.在安装或拆卸V形皮带时，务必将电源开关关掉，把电源插头从插座上拔下，并确认即使踩缝纫机踏板缝纫机也不会转动之后，再进行操作。
Before installing/removing the V belt,always turn off the power,unplug the machine and press the treadle to make sure the machine does not operate.
- 4.对于缝纫机机头的日常检查或定期检查，应按照本书及使用说明书的指示，切实认真的进行。
Carry out daily maintenance work and periodical inspections properly by following these precautions and the instruction manual.
- 5.缝纫机的修理或部件的更换请使用本公司的真实部件。对于不得当的修理、调整或使用假冒伪劣部件所造成的事故，本公司将不负一切责任。
Employ Pegasus genuine parts when repairing the machine and/or replacing the parts.We are not responsible for accidents caused by any improper repair/adjustment and substituting other parts for those manufactured by Pegasus.
- 6.请不要根据顾客自己的判断对缝纫机进行改造。否则因改造而发生的事故，本公司将不负一切责任。
Do not attempt to modify the machine at your own discretion.We are not responsible for accidents caused by the modification.
- 7.临时因修理、调整而拆卸下的安全装置、安全护罩，待作业完后务必按原来的状态安装好。
Be sure to replace the safety devices and/or safety covers that are temporarily removed for maintenance and/or adjustment.
- 8.维护、检查、修理的作业完成后，请检查接通电源之后是否确实没有危险。
After performing maintenance,check and repair,make sure that turning on the power does not pose any danger to you.

安全须知 请先仔细阅读 Be sure to study very carefully for safety.

4、警告标签粘贴的位置与安全保护装置 Location of warning labels and safety devices

	注意	运动的部分容易受伤。 安装安全保护装置方可进行 缝制作业。切断电源以后才 可进行穿线、交换梭芯或针、 清扫或调整作业。
	CAUTION	
		Moving parts may cause injury. Operate with safety devices. Turn off main switch before threading, changing bobbin and needle, cleaning etc.

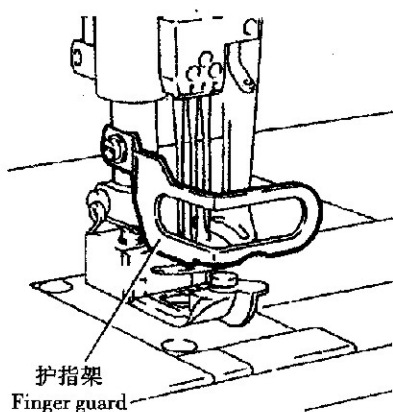
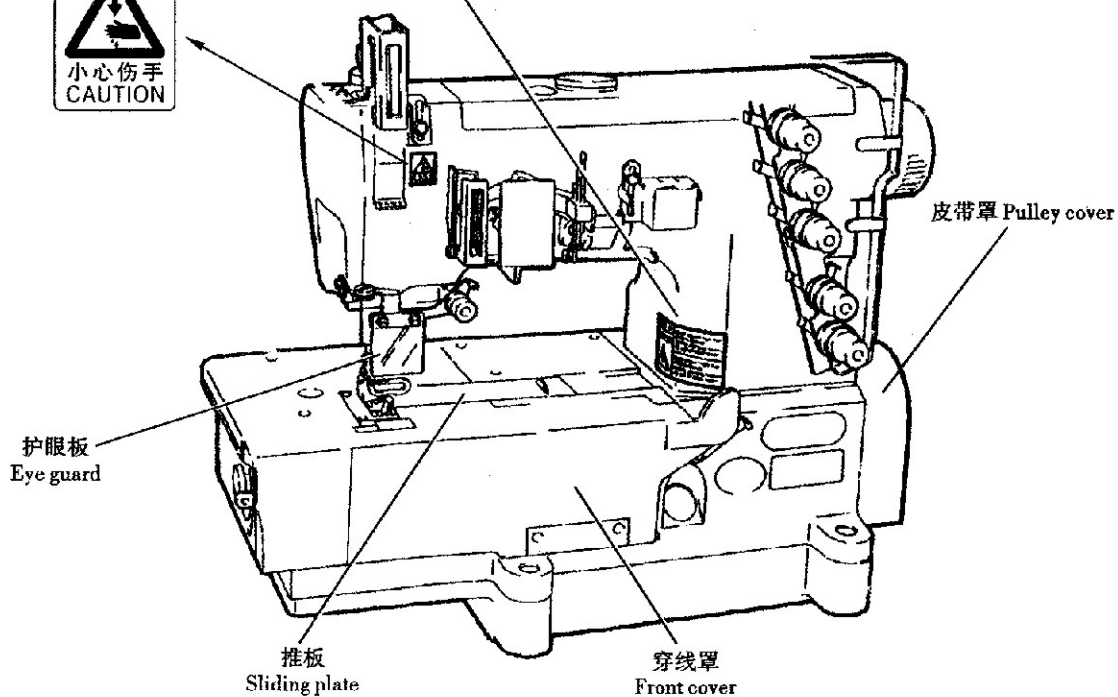

5、安全保护装置 Protectors for safety

这个项目是为了使大家都知道各种安全保护装置，并记载了各部分的注意事项。

This chapter describes each protector for safety. Therefore, read and study the following carefully.

(1) 护眼板 Eye guard

为了眼睛的安全，绝对不要在打开护眼板的状态下操作缝纫机。护眼板是为了在缝纫中针断了时，使断针不会飞入眼睛而安装的护眼罩。

For the safety of eyes, do not operate the machine with the eye guard open. The eye guard will prevent any pieces of the broken needle from getting into your eyes if the needle should break during sewing.

(2) 护指架 Finger guard

为了防止上下运动的机针与人接触而产生危险，在机针附近安装了护指架。但是，在护指架上方为了便于穿线而留有间隙。如果将手指从间隙伸入，机针有可能会刺伤手指造成危险。

To prevent the needle that moves up and down from contacting any of your body, the finger guard is installed close to the needle. However, there is clearance above the finger guard for easy threading. Be careful that the needle may penetrate any of your fingers if you insert it into this clearance.

(3) 皮带罩 Pulley cover

缝纫机的传动轮和V形皮带轮都被罩在皮带罩内，在缝纫中（特别在高速运转中）与人接触是很危险的。为了避免危险，务必长时使护罩处于安装好的状态。

The machine pulley and V belt are covered with the pulley cover. The machine pulley and the V belt rotate at high speed during sewing.

To prevent accidents, operate the machine with the pulley cover installed in place.

(4) 传动轮 Pulley

请确认缝纫机传动轮的旋转方向，正确的旋转方向在传动轮侧看是向右转的。

Check the direction in which the machine pulley rotates. It should rotate clockwise as seen from the pulley.

(5) 压脚 Presser foot

从针板表面压脚的上升量是5mm以上，这个间隙有夹手指的危险。在用膝盖开关抬升压脚时或用踏板自动抬升压脚时，请不要将手指伸入压脚下方。

There is a clearance of more than 5mm between the top surface of the needle plate and the presser foot. Be careful that none of your fingers are caught in this clearance. Never insert any of your fingers under the presser foot when raising the presser foot with the knee switch or automatically raising it with the treadle.

(6) 穿线罩 Front cover

弯针的运动从缝纫机正面看时，是进行左右往复的圆弧运动。为了避免进行圆弧运动的弯针与人接触，务必请在穿线罩闭合的状态下操作缝纫机。

The looper travels left to right while drawing an arc as seen from the front of the machine. To prevent the looper from contacting any part of your body, be sure to operate the machine with the front cover closed securely.

(7) 推板 Sliding plate

下线挑线器在缝纫时为了挑出一定量的下线在做旋转运动，为了避免进行旋转运动的下线挑线器与人接触，务必请在推板闭合的状态下操作缝纫机。

The looper thread take-up rotates in order to supply the required amount of looper thread during sewing. To prevent the looper thread take-up from contacting any of your body, be sure to operate the machine with the sliding plate closed securely.

安装台的组装 Assembling the machine rest board

请参照下图组装安装台。

组装时注意不要留缝隙或松动的地方，确实可靠的进行安装。

Assemble the components comprising the machine rest board by referring to the illustration below. Be sure to secure all rods, nuts and bolts firmly with no shake.

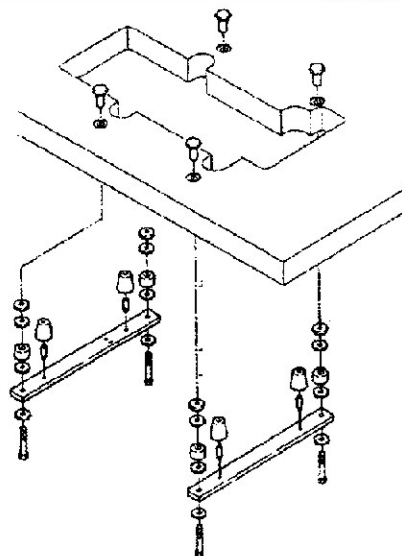

缝纫机的安装 Sewing machine installation

安装缝纫机时，务必将缝纫机的电源关掉，将插头从电源插销上拔下来之后再行。

Always turn off the power, unplug the machine and then well-qualified technicians should install the machine.

请将缝纫机安装在台板上之后，再安装V形传动皮带，然后调节缝纫机电机的位置，使之用手按压V形传动皮带中间部分时能有2cm的余量。

Mount the machine on the machine rest board first. Put the V belt in place. Position the machine motor so that an approx 2cm deflection can be obtained by pressing the center of the belt (see the illustration).

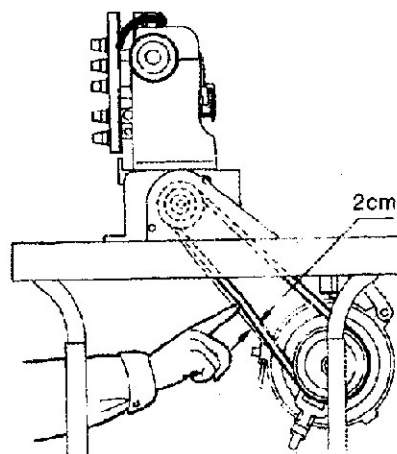

皮带轮护盖的安装 Installing the belt cover

安装皮带轮护盖时，务必将缝纫机的电源关掉，将插头从电源插销上拔下来之后再行。

Always turn off the power, unplug the machine and then well-qualified technicians should install the belt cover.

请参照右图，用螺丝2将皮带轮护盖1安装在缝纫机上。

Install belt cover 1 on the machine with screws 2.

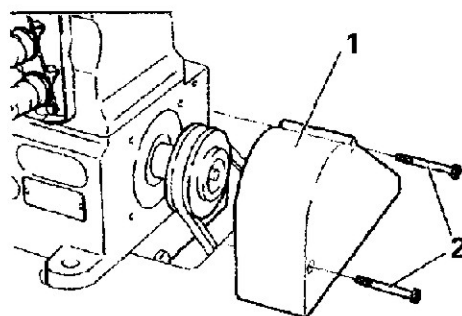

缝纫机的旋转方向 Operating direction of the machine pulley

缝纫机的旋转方向从手轮一侧看是向右旋转的。The machine pulley rotates clockwise as seen from the end of the machine pulley.

关于供油 Lubrication

在加机油或换机油时，请务必使用本公司指定的机油，如果使用指定以外的机油，有可能损坏缝纫机。

When lubricating the machine and/or replacing the oil, use our company recommended oil. Using other oils may damage the machine.

1. 使用的油类 Use the following oil

请使用本公司指定的高速缝纫机油或者使用与此相同的ESSOTEX SM22(Exxon Mobil制造)。Our company designated oil: HIGH SPEED SEWING MACHINE OIL or Equivalents: ESSOTEX Sm22 manufactured by Exxon Mobil.

2. 供油的方法 To fill the machine with oil

揭开供油口的盖子1，加油至油面到达油标尺的H线和L线中间，加完油后，请盖好供油口的盖子1。

Remove cap 1. Add the oil until the oil level (see oil gauge 2) reaches (H). After filling the tank with oil, replace cap 1.

3. 油的规定量 Required amount of oil

油标尺2的H线和L线表示着油量的上限和下限。为使油面经常保持在R线和L线之间，请常常检查注意加油。

(H) on oil gauge 2: Upper limit (L) on oil gauge 2: Lower limit The oil level should always lie between (H) and (L).

4. 用手加油 Manual lubrication

在用手加油时，务必将缝纫机的电源关掉，将插头从电源插销上拔下来之后再行。

Always turn off the power and unplug the machine when you apply oil by hand. In the beginning of using the sewing machine, or when using the sewing machine after a long time of not using it, apply two or three drops of oil to the needle bar 3 by hand.

Apply two or three drops of oil to needle bar 3 by hand when the machine is used for the first time or left unused for some time.

5. 检查机油的循环状况 Checking oil circulation

请在加完油后，踩下缝纫机踏板，使缝纫机运转，通过油窗4检查机油的循环状况是否良好。

Once the machine has been properly filled with oil, press the machine treadle to run the machine and check gauge window 4 to see if the oil is flowing.

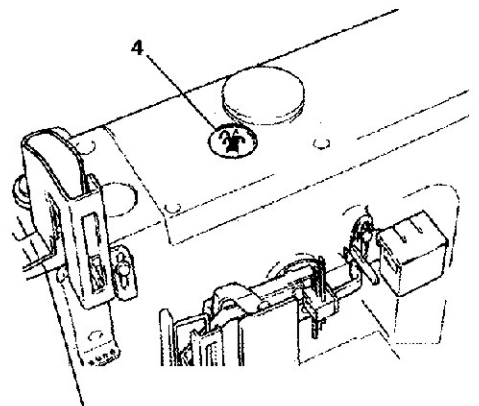
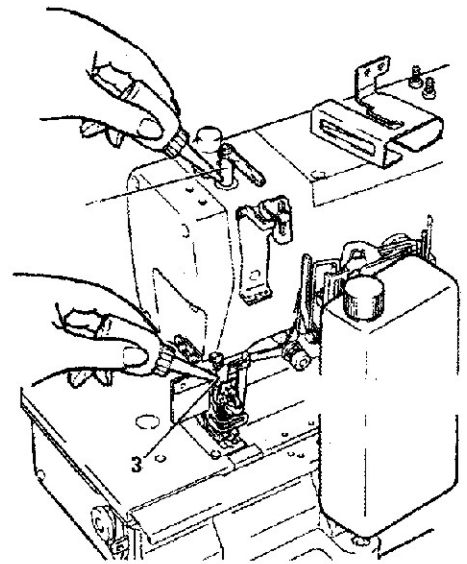
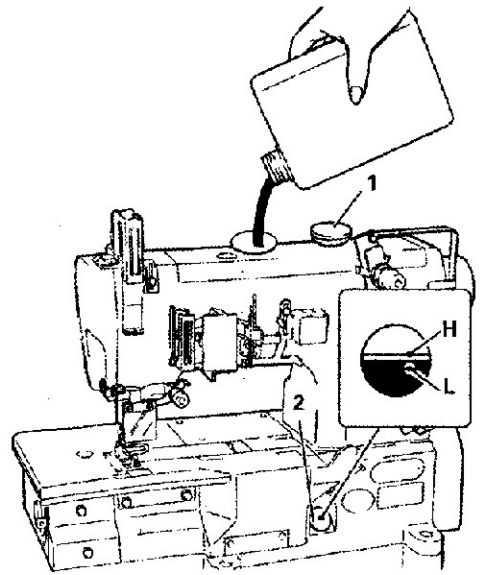

给HR装置供油 Silicone oil for H.R. device

在给HR装置供油时，务必将缝纫机的电源关掉，将插头从电源插销上拔下来之后再行。

Always turn off the power and unplug the machine when you fill the HR device with silicone oil.

在HR装置的硅油盒1·2，为了防止机线断线加有硅油，请经常检查，请尽早补充硅油。

Fill silicone oil tanks 1, 2 with silicone oil. To prevent thread breakage or fabric damage, add the silicone oil before it is too low.

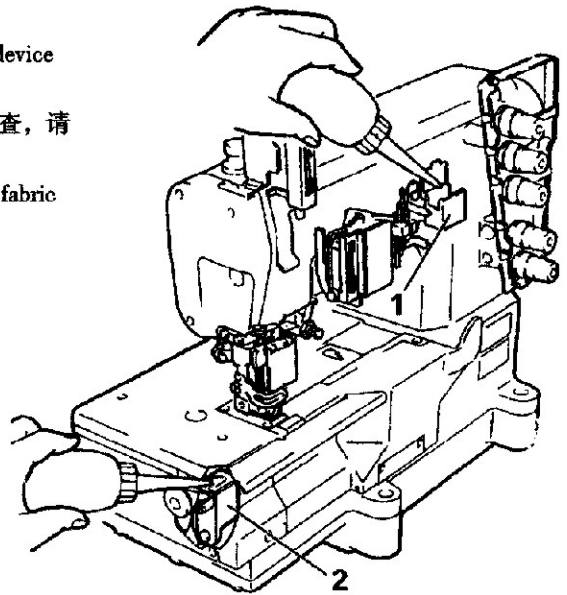

穿线的方法 Threading

在进行穿线时，务必将缝纫机的电源关掉，将插头从电源插销上拔下来之后再行。

Always turn off the power and unplug the machine when you thread the machine.

1. 请打开护眼罩1和护盖2、3、4

Open eye guard 1 and covers 2,3 and 4.

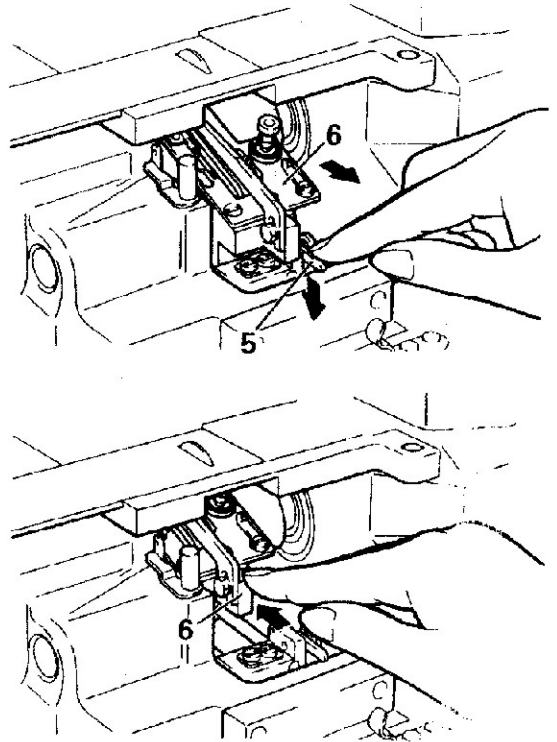
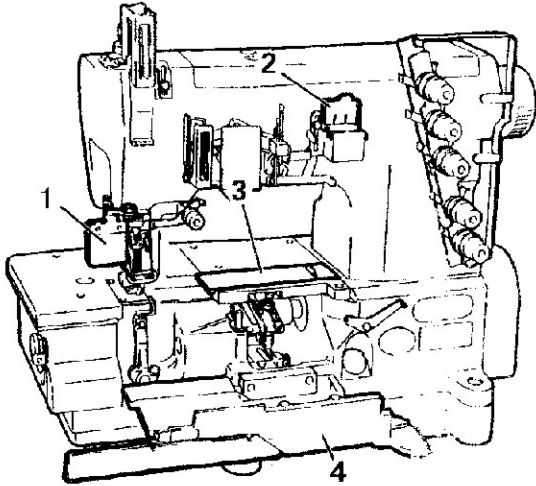

2. 请按板手5，这时下线挑线器6会挑出来，穿好线后，在返回原来的位置时，请按一下下线挑线器6。

Press lever 5 and bracket 6 comes out toward you. After threading, press bracket 6 into place.

3. (如果已穿好线时)

In case the machine is threaded previously
A部：请将已穿好的线与缝纫用线连接起来。

Knot the preset thread and the thread being used together to thread the machine.

B部：针线 Needle thread

将连接的针线穿到针眼前后，剪掉接头，再重新穿针线。

Trim the knots off neatly before passing through the eye of the needle to thread.

C部：弯针线、上装饰线

Looper thread, Top cover thread.

可一直将连接的线头穿好后，再用剪刀剪掉线头整好。

Trim the knots off neatly after passing through the eye of the looper.

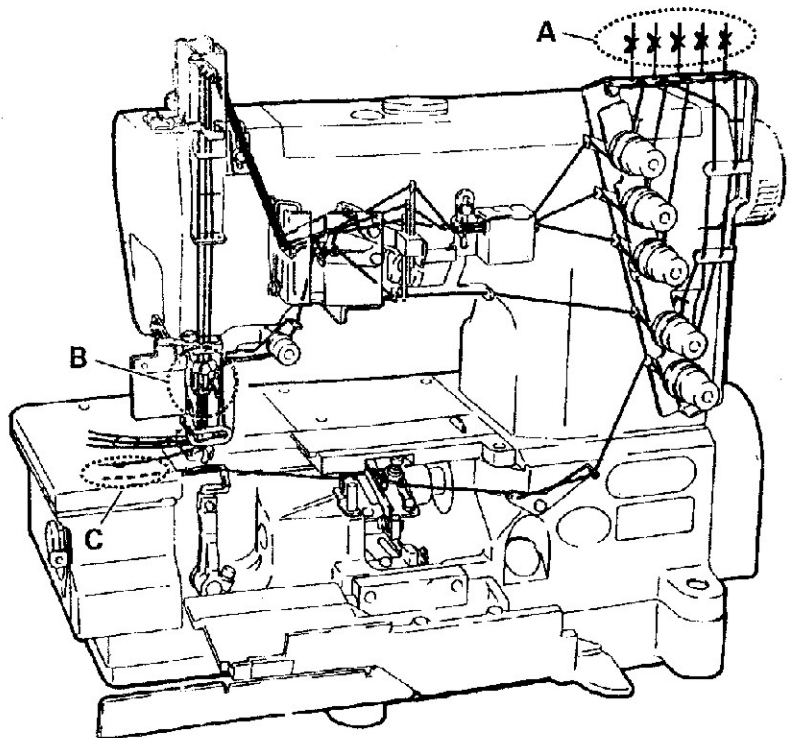

4. 穿线图 Threading diagram

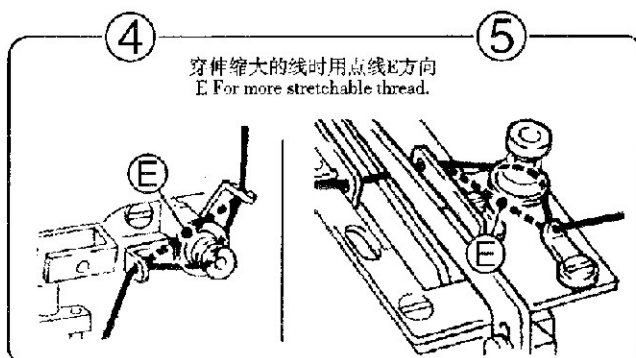
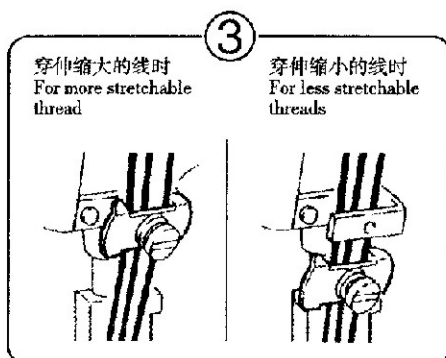
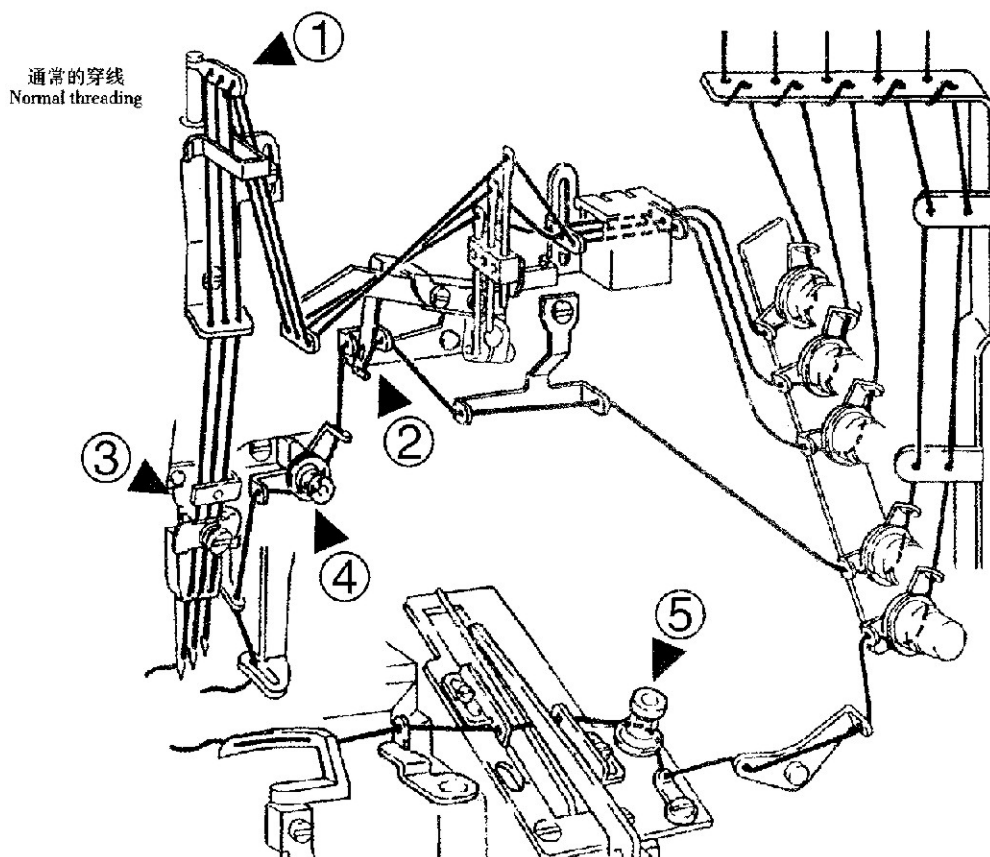
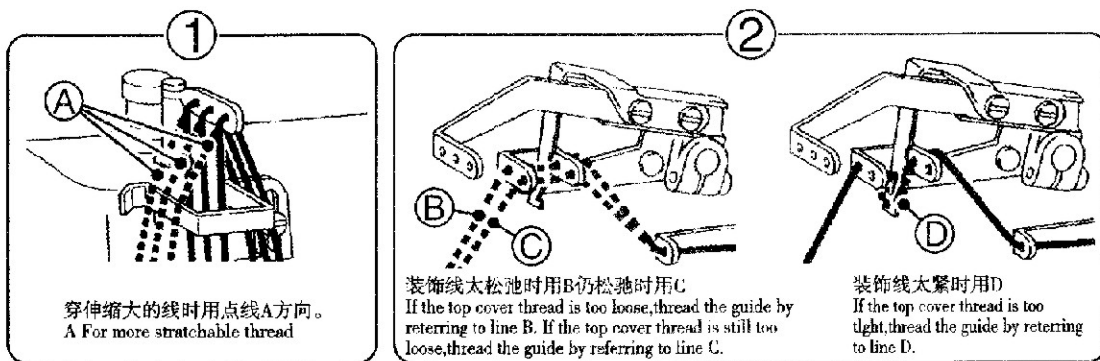

压脚压力的调节 Adjusting presser foot pressure

压脚的压力在送布能正确的进行，并且能缝出稳定针脚的范围内，请尽量使用较小的压力为宜。

The presser foot pressure should be as light as possible, yet sufficient to feed the fabric correctly and provide the uniform stitch formation.

松开螺母1，旋转螺丝2进行调节，调节完后拧紧螺母1。

Loosen nut 1, Adjust the presser foot pressure, Adjustment is made by turning screw 2 clockwise or counterclockwise. Tighten nut 1.

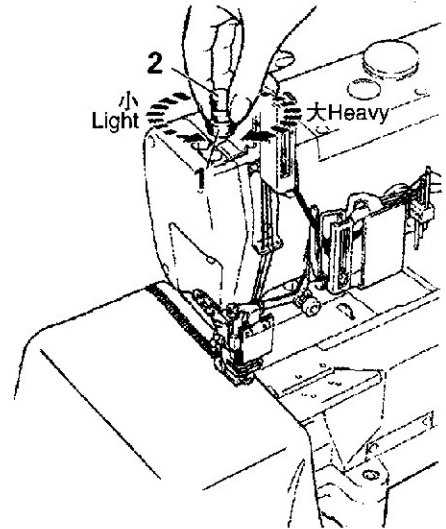

差动比的调节 Adjusting the differential feed ratio

1. 松开螺母3，将板手4向下扳，则差动比变大，缝纫的布料会伸长。

Loosen nut 3 for the differential feed ratio adjustment.

To increase the differential feed ratio, lower lever 4.

The finished fabric is shrunk.

To decrease the differential feed ratio, raise lever 4.

The finished fabric is stretched.

2. 调节完后，请将螺母3拧紧。

After this adjustment tighten nut 3.

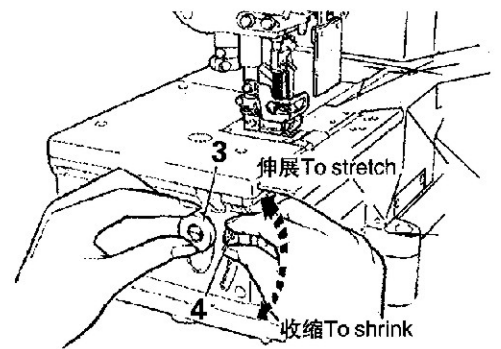

针脚长度的调节 Adjusting stitch length

在调节针脚长度时，务必将缝纫机的电源关掉，并将插头从电源插销上拔下来之后，再请专门的技术人员进行操作。

Always turn off the power and unplug the machine when adjusting the stitch length.

1. 一边轻轻按着套式按钮5，一边转动手轮6，这时套式按钮会陷下去一些。

While pressing the push button 5, turn the handwheel 6 to seek the position at which the push button 5 goes further into the depth.

2. 请继续按着套式按钮5，并转动手轮6，使所希望的刻度与记号A相吻合。

Then keeping the push button 5 pressed, turn the handwheel 6 and set the desired scale to the aligning mark A.

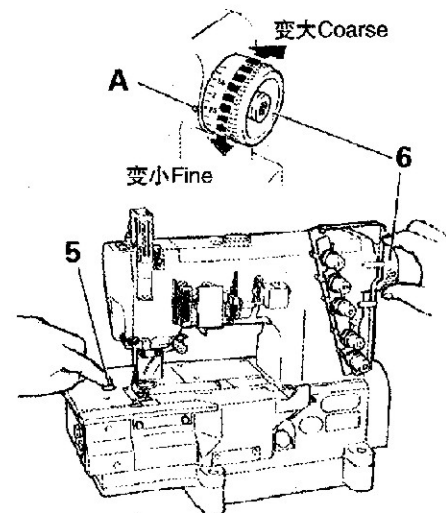

注: Note

缝纫针脚长度的调节，请务必在调节差动比之后进行。

Stitch length adjustment must only be made after the differential feed ratio has been changed.

线状态的调节 Adjusting the thread tension

线状态的调节请用针线调节旋钮1，上装饰线调节旋钮2和下弯针调节旋钮3进行调节。

To obtain the proper thread tension, adjust needle thread tension knobs 1, top cover thread tension knobs 2 and looper thread tension knob 3.

想将线拉紧一些时，可将各旋钮向右旋转，想松一些时可向左旋转。在能取得均匀且漂亮缝纫效果的情况下，尽量采用较松的夹线状态。

To tighten the thread, turn each knob clockwise.

To loosen the thread, turn each knob counterclockwise.

Each thread tension should be as light as possible, yet be sufficient to produce balanced and beautiful stitches.

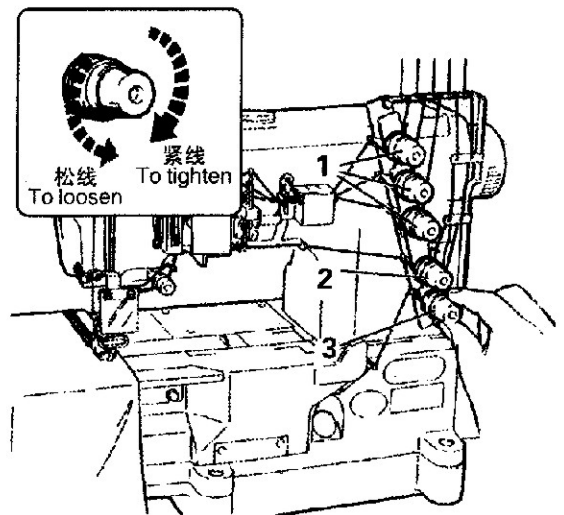

缝纫机的清扫 Cleaning the machine

在清扫缝纫机时，务必将缝纫机的电源关掉，将插头从电源插销上拔下来之后再行。

Always turn off the power and unplug the machine when you clean the machine.

1. 打开穿线罩4和推板5，请松开螺丝6，卸下针板7。

Open front cover 4 and slide plate 5. Loosen screws 6 and remove needle plate 7.

2. 请打扫针板的空槽和送布牙周围。

Clean the grooves of the needle plate and the area around the feed dogs.

3. 请用螺丝6安装针板7，并且关闭穿线罩4和推板5。

Replace needle plate 7 with screws 6. Then close front cover 4 and slide plate 5.

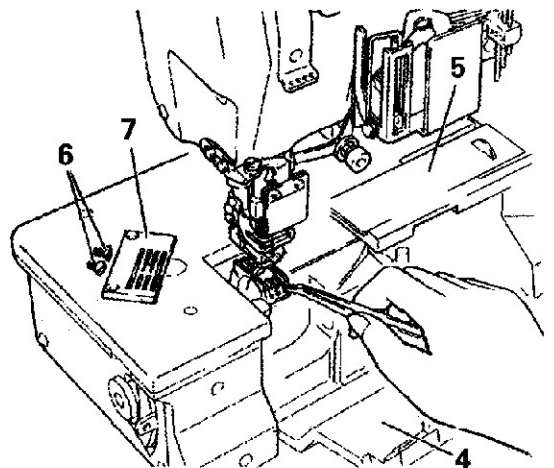

机针的更换 Replacing the needle

在更换机针时，务必将缝纫机的电源关掉，将插头从电源插销上拔下来之后再行。

Always turn off the power and unplug the machine when you replace the needle(s).

1. 请使用红色把柄（1.5mm）的六角螺丝刀松开固定螺丝1。

Loosen screw(s) 1 using a red-handled key wrench(1.5mm).

2. 用附带工具箱的镊子将旧针取下来。

Remove the old needle(s) by using a pincette (provided as accessories).

3. 将机针的凹槽朝着缝纫机后面进行安装。

Fix the needle so that its scarf faces the rear side of machine.

4. 用镊子将新针插入到针箍架孔的最深处。

Insert a new needle into the neele hole as far it will go by using a pincette.

5. 然后使用红色把柄（1.5mm）的六角螺丝刀拧紧固定螺丝1。

Tighten screw(s) 1 using a red-handled key wrench(1.5mm).

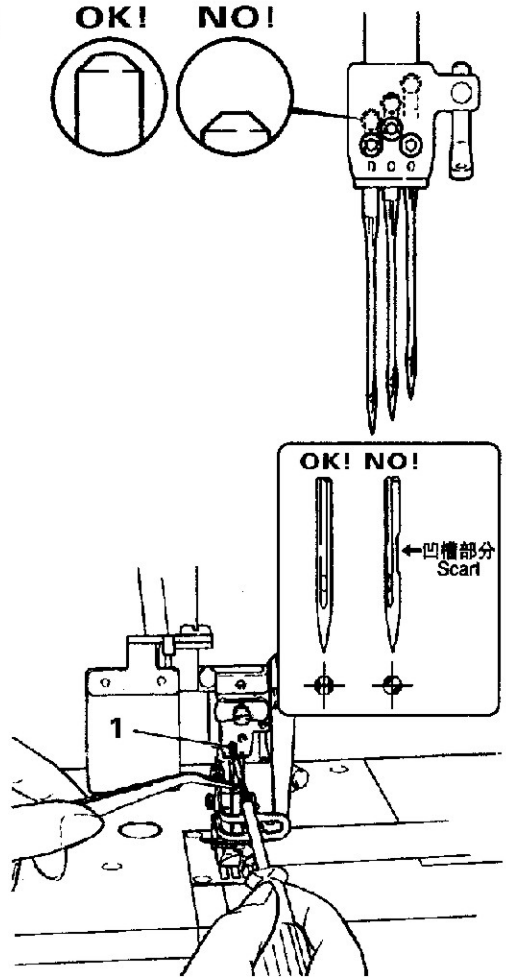

机油的更换 Oil replacement

缝纫机在开始使用1个月后更换一次机油，然后请每6个月更换一次机油。如果不更换机油继续使用，缝纫机有可能发生故障。

Replace the oil one month after the first use and thereafter every six months. If you keep using the old oil it may cause the damage to the machine.

排油的方法 To drain the oil

1. 请卸开油箱底座排油孔盖螺丝2，排出旧油。

Drain the oil by removing screw 2 on the left side of the oil pan.

2. 排完油后，将排油孔盖螺丝2拧紧。

Tighten screw 2 after draining.

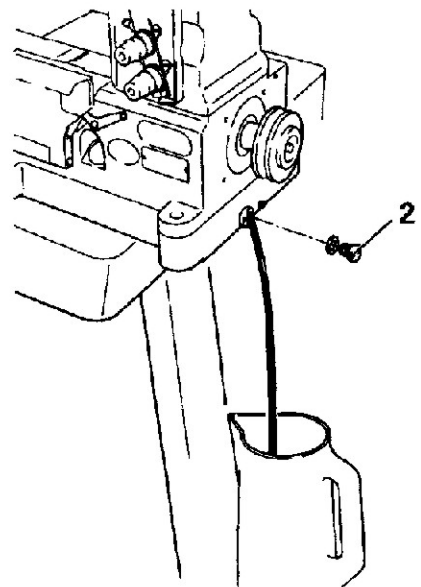

油泵滤油网的检查与清扫 Checking and cleaning the oil filter

在进行油泵滤油网的检查与清扫时，务必将缝纫机的电源开关关掉，将电源插头从插座上拔下之后，请专门的技术人员进行操作。

Always turn off the power, unplug the machine and then well-qualified technicians should check and clean the oil filter.

每6个月请将油泵滤油网卸下来检查、清扫一次。

Check and clean the oil filter every six months.

To check and clean the oil filter.

1. 卸下螺丝1、2，然后请卸下油盘3。

Remove screws 1 and 2, Remove oil reservoir 3.

2. 松开螺丝4，拆卸下过滤网5（内）和过滤网6（外），然后请进行检查和清扫。

Loosen screw 4, Remove inner and outer filters 5 and 6.

Then check and/or clean these filters.

3. 请将油盘3（内）过滤网5和（外）过滤网6按原来的样子进行安装。

Reinstall oil reservoir 3, filters 5 (inner) and 6 (outer).

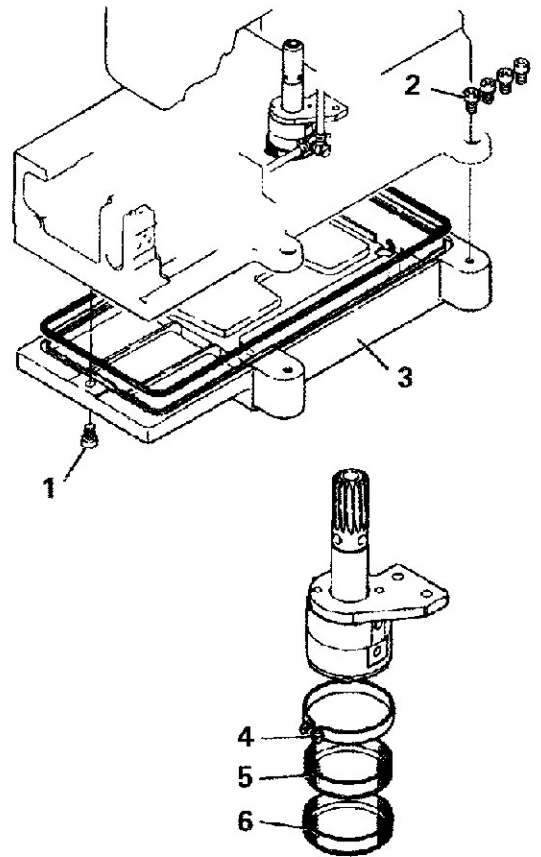

2.零件手册

PARTS LIST

2.1 机壳结构 (A) MACHINE BED FRAME (A)

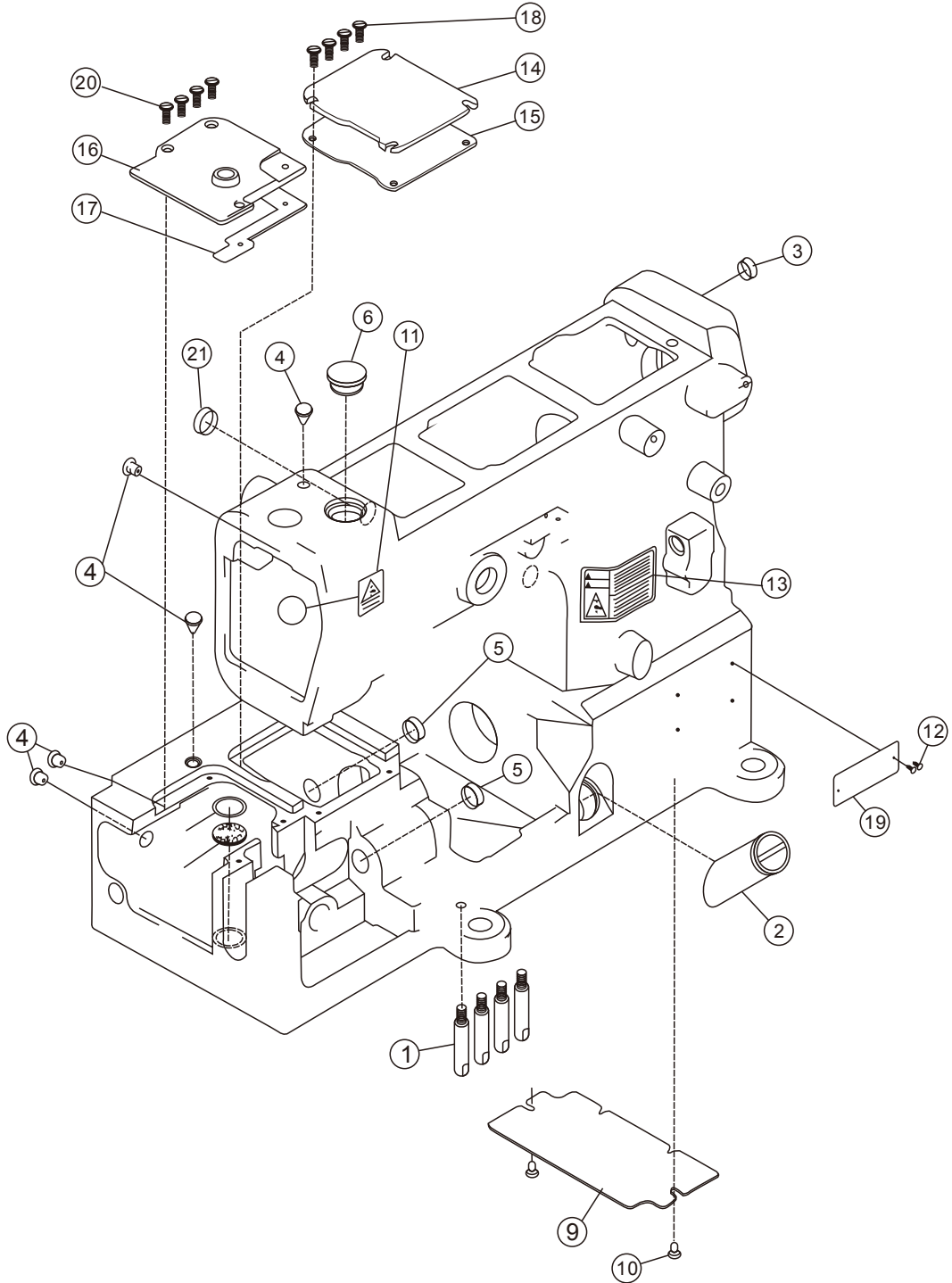

2.1 机壳结构(A) MACHINE BED FRAME(A)

序号 PEF NO	件 号 PART NO	名 称	DESCRIPTION	数量 QTY	
				562A	562A-BD
1	10042368	机座螺钉	BED PIN	4	4
2	10042369	油量指示窗	OIL LEVEL GAUGE	1	1
3	10042370	抬压轴后油塞	PLUG	1	1
4	10042371	机头油塞	PLUG	5	5
5	10010782	橡胶塞	PLUG	2	2
6	10008964	橡胶塞	PLUG	1	1
7	10003330	Φ18 挡圈	RING	3	3
8	10042375	滤油网	FILTER	3	3
9	10042376	底盖板	COVER	1	1
10	10042377	底盖板螺钉	SCREW	2	2
11	10043147	三角形标贴	CAUTION LABEL	1	1
12	10002840	2×5 铆钉	PIN	2	2
13	10008936	机头安全提示牌	STICKER	1	1
14	10042378	弯针传动盖板	TOP COVETR PLATE (RIGHT)	1	1
15	10042379	弯针传动盖板垫	GASKET	1	1
16	10042380	针距按钮盖	TOP COVETR PLATE (LEFT)	1	1
17	10042381	针距按钮盖密封垫	GASKET	1	1
18	10042382	弯针传动盖板螺钉	SCREW	4	4
19	10052657	型号牌☆	MMODEL CARD☆	1	1
20	10042440	针距按钮盖螺钉	SCREW	4	4
21	10010931	油封	OIL SEAL	1	1

2.2 机壳结构 (B) MACHINE BED FRAME (B)

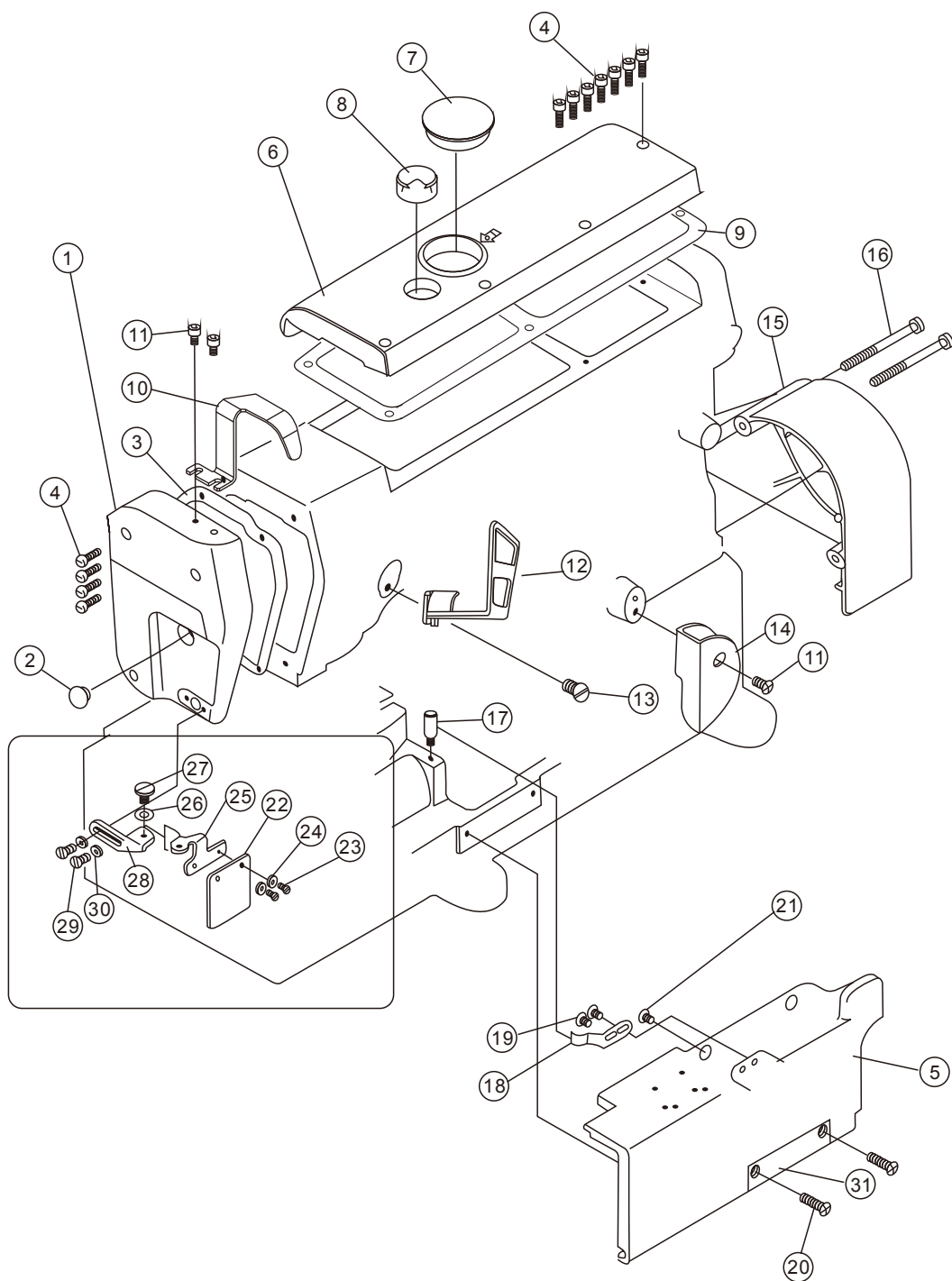

2.2 机壳结构(B) MACHINE BED FRAME(B)

序号 PEF NO	件号 PART NO	名称	DESCRIPTION	数量 QTY	
				562A	562A-BD
1	10042384	面板☆	FACE PLATE☆	1	1
2	10013170	橡胶塞	PLUG	1	1
3	10042386	面板密封垫	PANEL SEAL GASKET	1	1
4	10042387	面板螺钉	SCREW	11	11
5	10052829	穿线罩板	FRONT COVER	1	0
6	10042389	上盖板	UPPER COVER PLATE	1	1
7	10042390	上盖闷头	PLUG	1	1
8	10042391	喷油窗	OIL SIGHT WINDOW	1	1
9	10042392	上盖板垫	SEAL	1	1
10	10042393	挑线杆防护罩	NEEDE BAR GUARD	1	1
11	10042394	挑线杆防护罩螺钉	SCREW	3	3
12	10042395	过线防护罩	BARCKET	1	1
13	10042396	螺钉	SCREW	1	1
14	10042397	底过线导板	LOOPER THREAD GUIDE COVER	1	1
15	10042398	皮带罩☆	PULLER COVER☆	1	1
16	10042399	皮带罩螺钉	SCREW	2	2
17	10042400	底线过线连接柱	SCREW	1	1
18	10042401	穿线罩弹簧	FLAT SPRING	1	1
19	10042402	螺钉	SCREW	2	2
20	10042403	穿线罩板铰链螺钉	SCREW	2	2
21	10042404	防震垫	CUSHION	1	1
22	10042405	防护罩	EYE GUARD	1	1
23	10042406	防护罩螺钉	SCREW	2	2
24	10042407	防护罩垫圈	WASHER	2	2
25	10042408	防护罩支架	BRACKET	1	1
26	10009470	垫圈	WASHER	1	1
27	10042410	螺钉	SCREW	1	1
28	10042411	防护罩座	BRACKET	1	1
29	10042412	螺钉	SCREW	2	2
30	10003083	垫圈	WASHER	2	2
31	10042415	穿线罩铰链	COVER	1	1

2.3 机壳结构(C) MACHINE BED FRAME (C)

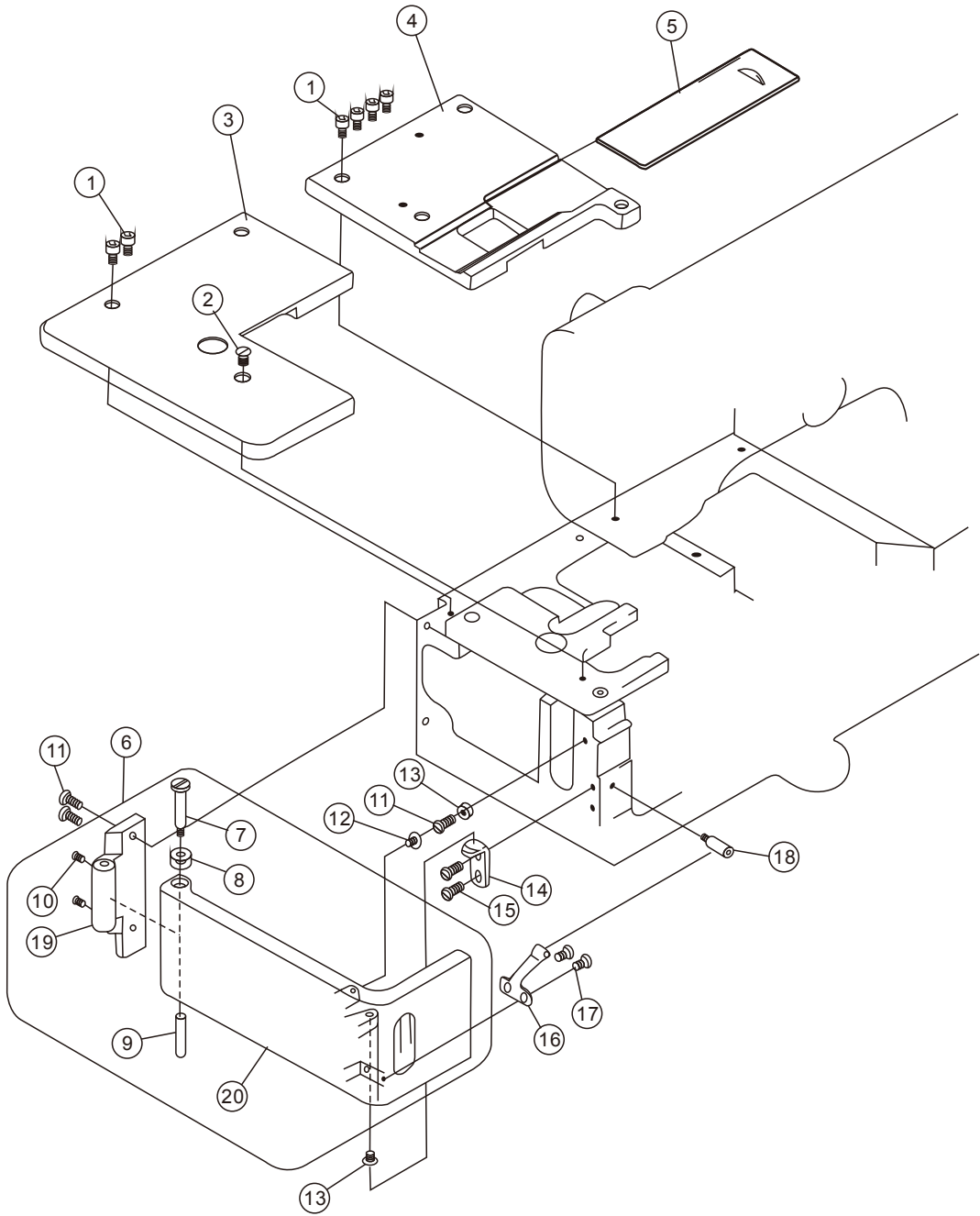

2.3 机壳结构(C) MACHINE BED FRAME(C)

序号 PEF NO	件号 PART NO	名称	DESCRIPTION	数量 QTY	
				562A	562A-BD
1	10042387	螺钉	SCREW	6	6
2	10042420	缝台左罩定位螺钉	SCREW	1	1
3	10042421	缝台左罩	BED COVER (LEFT)	1	1
4	10042954	缝台右罩	BED COVER (RIGHT)	1	1
5	10042423	推板组件	COVER	1	1
6	10043224	左侧罩组件	SUDE COVER ASSEMBLY	1	1
7	10042427	螺钉	SCREW	1	1
8	10042419	垫圈	SPRING	4	4
9	10042428	左侧罩铰链销轴	PIN	1	1
10	10042429	铰链上头螺钉	SCREW	2	2
11	10042412	螺钉	SCREW	3	3
12	10042404	防震塞	CUSHON	2	2
13	10042424	螺母	NUT	1	1
14	10042425	防震板	BRACKLT	1	1
15	10042394	螺钉	SCREW	2	2
16	10042426	前罩板弹簧	FALT SPRING	1	1
17	10042402	螺钉	SCREW	2	2
18	10042400	螺钉	SCREW	1	1
19	10042430	左侧板铰链板	LINK COVER	1	1
20	10042431	左罩板	COVER (LEFT)	1	1

2.4 下轴传动机构 CRANK SHAFT DRIVE MECHANISM

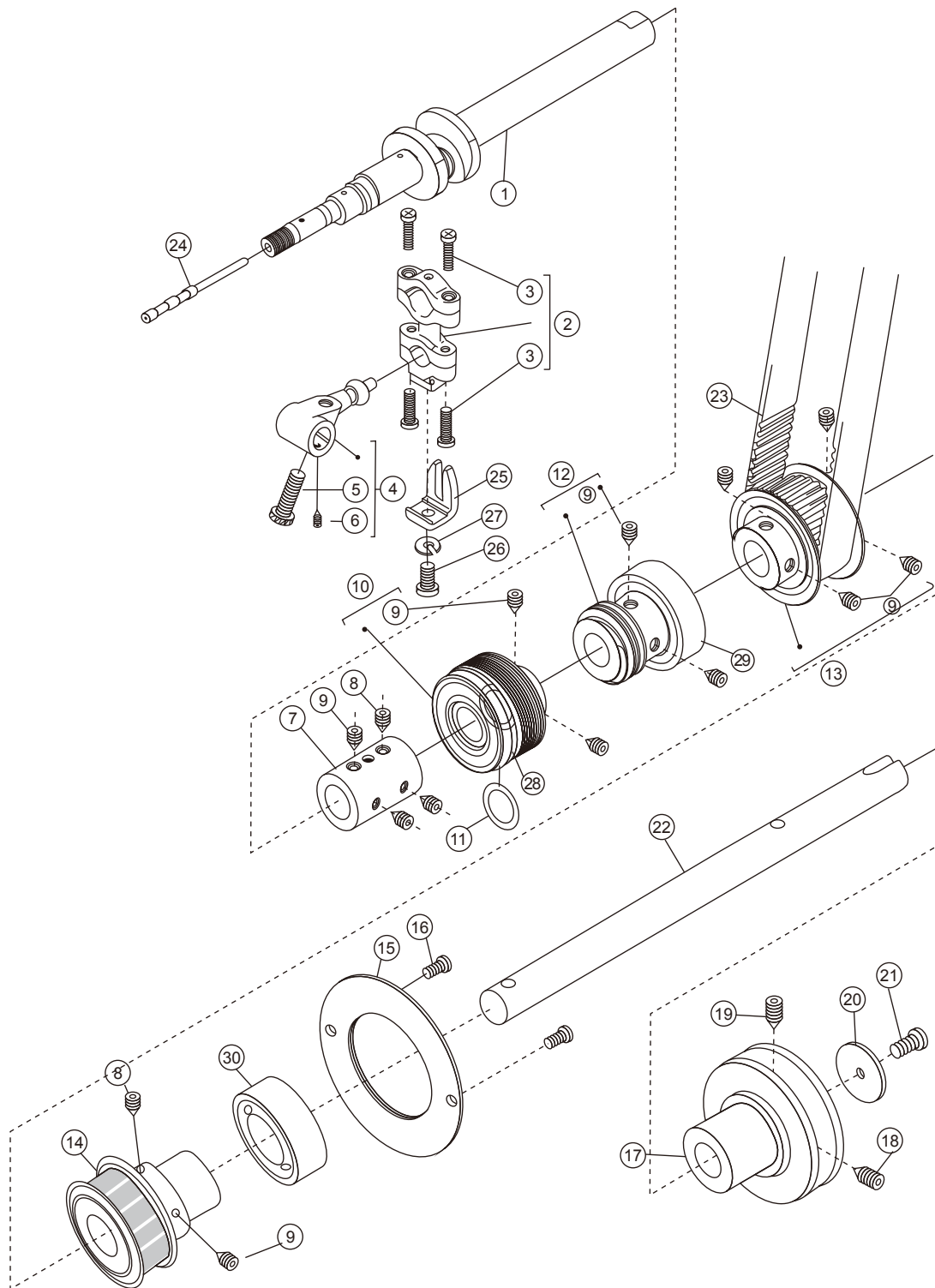

2.4 下轴传动机构 CRANK SHAFT DRIVE MECHANISM

序号 PEF NO	件号 PART NO	名称	DESCRIPTION	数量 QTY	
				562A	562A-BD
1	10042432	下轴前节轴	CRANK SHAFT ASSEMBLY	1	1
2	10042454	弯针连杆组件	CONNECTION ASSEMBLY	1	1
3	10042387	螺钉	SCREW	8	8
4	10042433	球曲柄	CRANK)	1	1
5	10042434	螺钉	SCREW	1	1
6	10042435	螺钉	SCREW	1	1
7	10042436	联轴器	JOINT	1	1
8	10042437	螺钉	SCREW	2	2
9	10042438	螺钉	SCREW	12	12
10	10042455	下轴中衬套	BUSHING	1	1
11	10042456	O型圈	O RING	1	1
12	10042459	油泵涡轮	BUSHING	1	1
13	10042910	主动同步带轮组件	GEAR	1	1
14	10042909	打线主动同步带轮组件	GEAR	1	1
15	10042439	压紧圈	COVER	1	0
16	10042440	压紧圈螺钉	SCREW	2	0
17	10042441	皮带轮	SCREW	1	0
18	10042442	螺钉	SCREW	1	0
19	10042443	螺钉	SCREW	1	0
20	10042444	从动轮垫片	WASHER	1	0
21	10042445	从动轮定位螺钉	SCREW	1	0
22	10042446	下轴后节	SHAFT	1	0
23	10050281	同步带	TIMING BELT	1	1
24	10042448	下轴油量调节芯针	ADJUSTING BAR	1	1
25	10042449	叉口	GUIDE	1	1
26	10042450	叉口螺钉	SCREW	1	1
27	10042451	开口垫圈	WASHER	1	1
28	10047363	轴承O型圈组件	BEARING	1	1
29	10047364	轴承O型圈组件	BEARING	1	1
30	10042466	轴承	BEARING	1	1

2.5 上轴传动机构 ARM SHAFT DRIVE MECHANISM

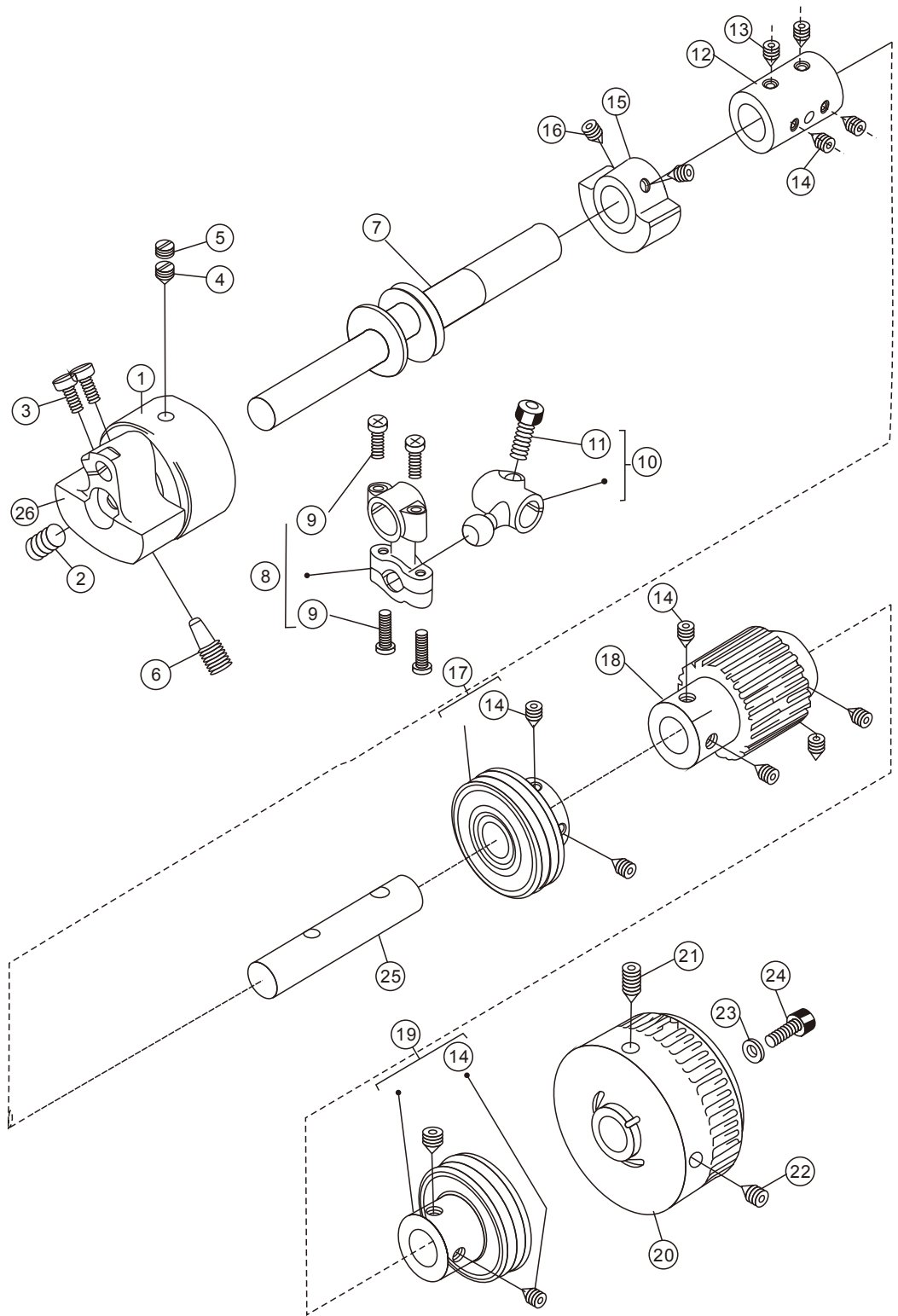

2.5 上轴传动机构 ARM SHAFT DRIVE MECHANISM

序号 PEF NO	件号 PART NO	名称	DESCRIPTION	数量 QTY	
				562A	562A-BD
1	10051893	针杆曲柄轴承组	MOTION ASSEMBLY	1	1
2	10042480	针杆曲柄紧固螺钉	SCREW	1	1
3	10042481	针杆曲柄夹紧螺钉	SCREW	2	2
4	10042468	定位螺钉	SCREW	1	1
5	10042469	止动螺钉	SCREW	1	1
6	10042470	长锥定位螺钉	SCREW	1	1
7	10042471	上轴前节曲轴	CRANK SHAFT	1	1
8	10042484	上线挑线连杆	CONNECTION ASSEMBLY	1	1
9	10042387	螺钉	SCREW	4	4
10	10042472	上挑线球曲柄	BALL CRANK	1	1
11	10042434	球曲柄螺钉	SCREW	1	1
12	10042436	联轴器	JOINT	1	1
13	10042437	联轴器定位螺钉	SCREW	1	1
14	10042438	螺钉	SCREW	10	10
15	10042473	上轴平衡块	BALANCE WEIGHT	1	1
16	10042511	螺钉	SCREW	2	2
17	10051894	上轴前衬套轴承组	BUSHING	1	1
18	10042475	从动时规轮	GEAR(UPPER)	1	1
19	20014770	后衬套组件	BUSHING	1	1
20	10042476	手轮☆	HAND WHEEL☆	1	1
21	10042442	螺钉	SCREW	1	1
22	10042443	螺钉	SCREW	1	1
23	10042477	上轮垫圈	WASHER	1	1
24	10042478	上轮螺钉	SCREW	1	1
25	10042474	上轴后节	SHAFT	1	1
26	10042479	针杆曲柄	NEEDLE BAR CRANK	1	1

2.6 针杆结构 NEEDLE BAR MECHANISM

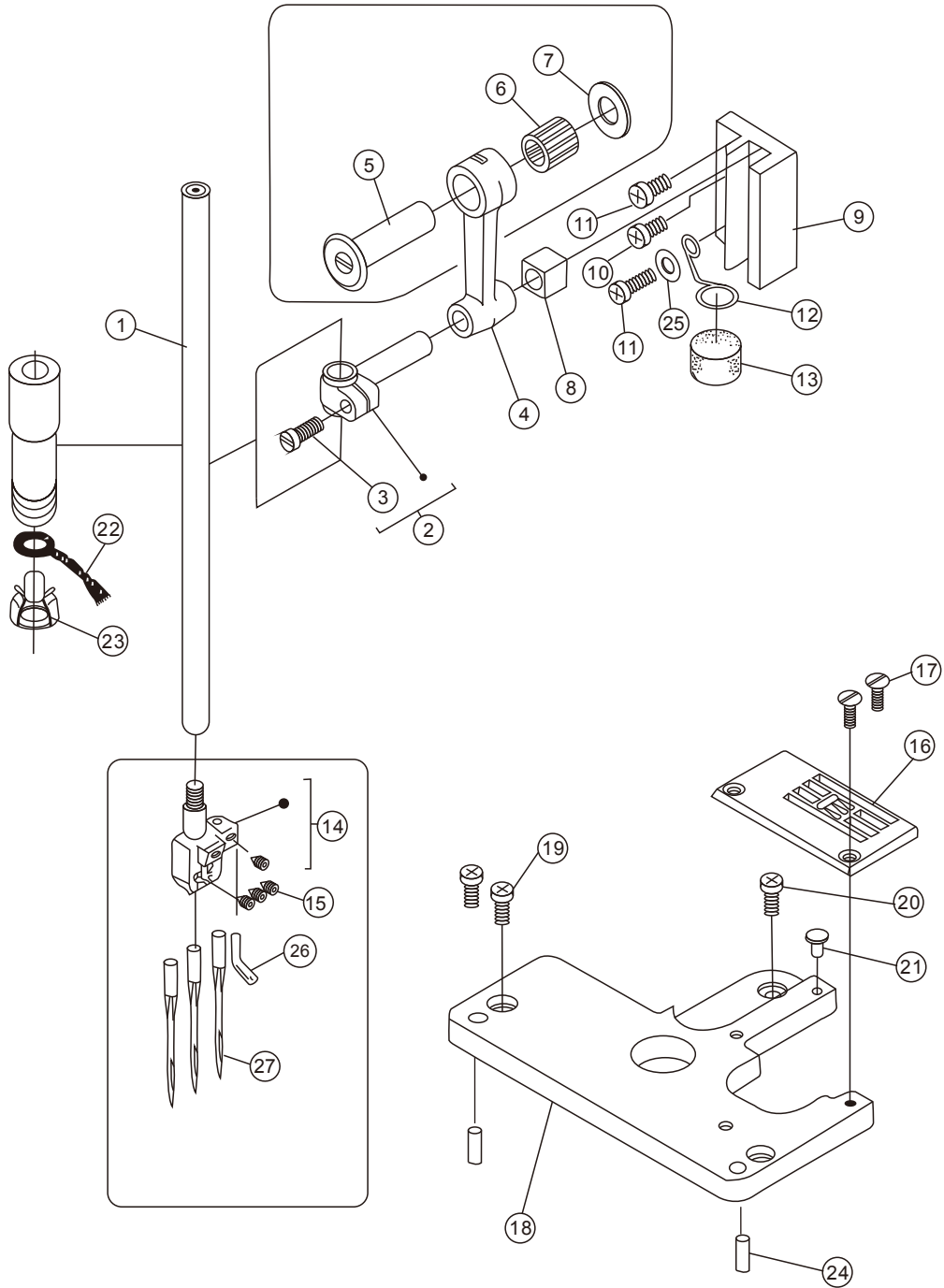

2.6 针杆机构 NEEDLE BAR DRIVE MECHANISM

序号 PEF NO	件 号 PART NO	名 称	DESCRIPTION	数量 QTY	
				562A	562A-BD
1	10042487	针杆	NEEDLE BAR	1	1
2	10042488	针杆接头	NEEDLE BAR CLAMP	1	1
3	10042489	针杆接头螺钉	SCREW	1	1
4	10042490	针杆连杆	NEEDLE BAR DRIVING LINK	1	1
5	10042491	针杆连杆销	PIN	1	1
6	10048172	滚针轴承	NEEDLE BEARING	1	1
7	10042493	垫圈	WASHER	1	1
8	10042494	针杆滑块	BLOCK	1	1
9	10042495	针杆滑块座	NEEDLE BAR BLOCK GUIDE	1	1
10	10012752	螺钉	SCREW	1	1
11	10003102	针杆滑块座螺钉	SCREW	2	2
12	10042497	油毡定位圈	LATCH	1	1
13	10042498	油毡	SPONGE	1	1
14	*	针夹	NEEDLE HOLDER	1	1
15	10042500	针夹螺钉	SCREW	4	4
16	*	针板	NEEDLE PLATE	1	1
17	10042502	针板螺钉	SCREW	2	2
18	10042503	针板接板	BRACKET	1	1
19	10042394	螺钉	SCREW	2	2
20	10042440	螺钉	SCREW	1	1
21	10042504	防震塞	CUSHION RUBBER	1	1
22	10008069	油线	OIL WICK	1	1
23	10042506	针杆上套油线夹头	OIL WICK RETAINER	1	1
24	10042509	针板接板定位销	PIN	2	2
25	10002954	垫圈	RING	1	1
26	10042291	过线杆	THREAD GUIDE	1	1
27	10004902	UY128GBS 11#机针	NEEDLE	3	3

“*”具体内容参看专用件表

Part number for “*”

Please refer the '2.22. Gauge Parts List'

2.7 保针机构 NEEDLE GUARD MECHANISM

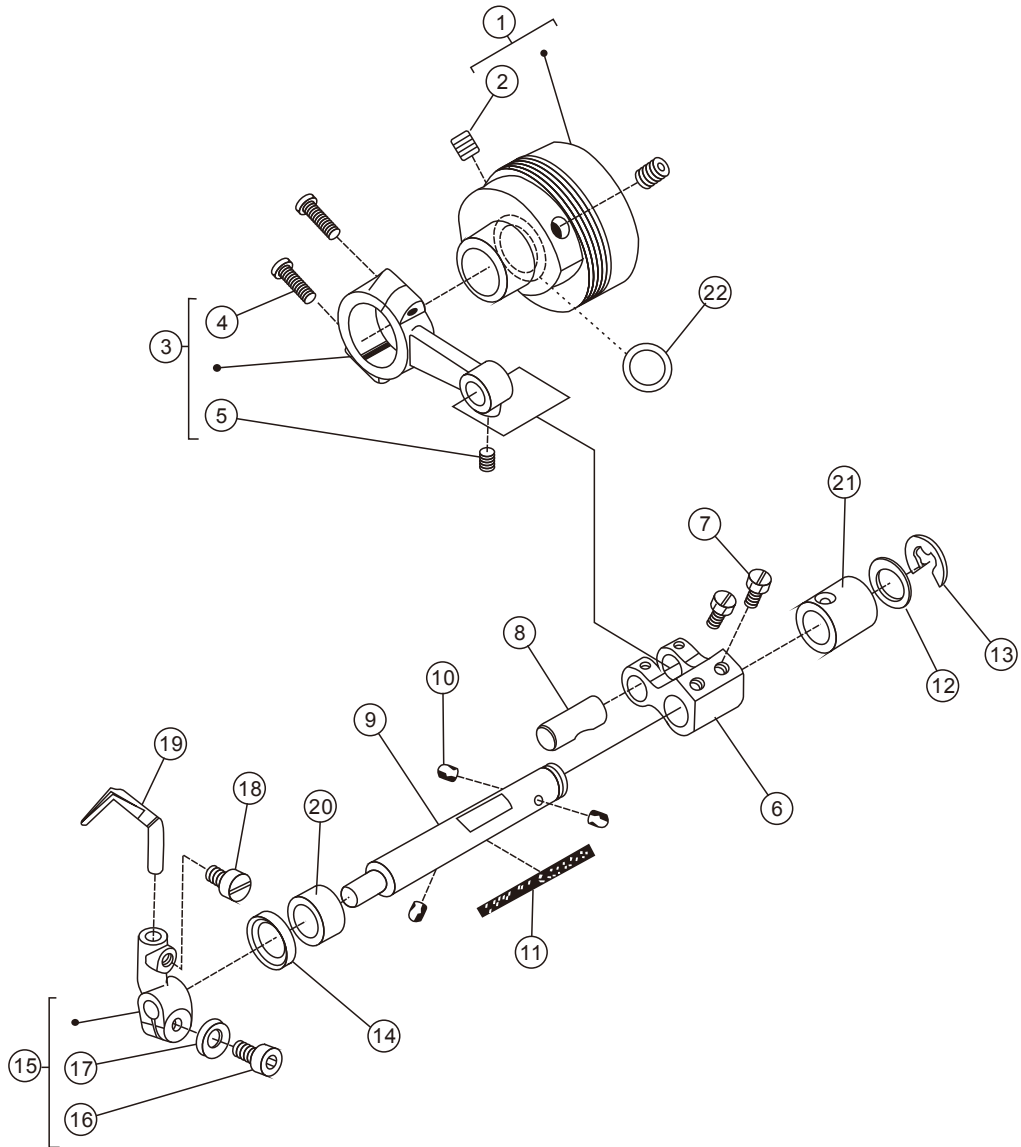

2.7 保针机构 NEEDLE GURAD MECHANISM

序号 PEF NO	件号 PART NO	名称	DESCRIPTION	数量 QTY	
				562A	562A-BD
1	10042527	下轴前衬套	ECCENTRIC ASSEMBLY	1	1
2	10042511	下轴前衬套螺钉	SCREW	2	2
3	10042528	保针连杆组件	CONNECTION ASSEMBLY	1	1
4	10042387	螺钉	SCREW	2	2
5	10042429	螺钉	SCREW	1	1
6	10042512	保针曲柄	CRANK	1	1
7	10042513	保针曲柄螺钉	SCREW	2	2
8	10042514	保针曲柄销	PIN	1	1
9	10042515	保针轴	SHAFT	1	1
10	10008090	油线	OIL WICK	1	1
11	10008088	油线	OIL WICK	1	1
12	10042518	保针轴垫圈	WASHER	1	1
13	10050347	挡圈	RING	1	1
14	10042520	保针轴骨架防油圈	OIL SEAL	1	1
15	10042521	保针座	NEEDLE GUIDE HOLDER	1	1
16	10042445	螺钉	SCREW	1	1
17	10009429	垫圈	WASHER	1	1
18	10042523	螺钉	SCREW	1	1
19	10043132	后保针	NEEDLE GUIDE (REAR)	2	2
20	10042525	保针轴左套	BUSHING (LEFT)	1	1
21	10042526	保针轴右套	BUSHING (RIGHT)	1	1
22	10042456	下轴前衬套 O 型圈	O RING	1	1

2.8 弯针机构 LOOPER DRIVE MECHANISM

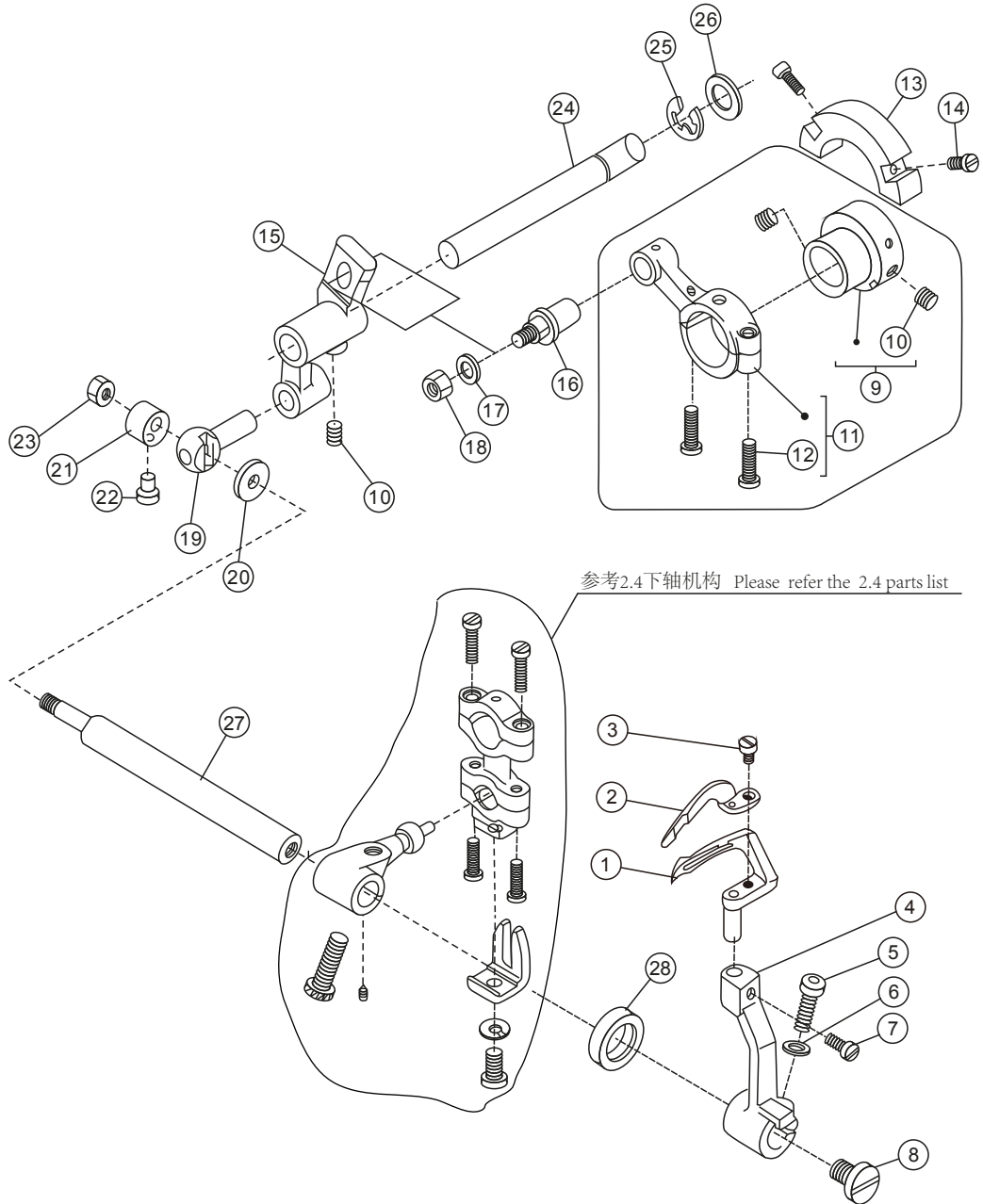

2.8 弯针机构 LOOPER DRIVE MECHANISM

序号 PEF NO	件号 PART NO	名称	DESCRIPTION	数量 QTY	
				562A	562A-BD
1	10043134	弯针	LOOPER	1	1
2	10043135	前保针	NEEDLE(FRONT)	1	1
3	10042524	螺钉	SCREW	1	1
4	10042529	弯针曲柄	LOOPER HOLDER ASSEMBLY	1	1
5	10042478	螺钉	SCREW	1	1
6	10009429	垫圈	WASHER	1	1
7	10042530	螺钉	SCREW	1	1
8	10042531	弯针曲柄调节螺钉	SCREW	1	1
9	10042534	偏心凸轮	ECCENTRIC ASSEMBLY	1	1
10	10042511	螺钉	SCREW	3	3
11	10042548	弯针连杆组件	CONNECTION ASSEMBLY	1	1
12	10042387	螺钉	SCREW	2	2
13	10042535	平衡块	BALANCE WEIGHT	1	1
14	10042536	螺钉	SCREW	2	2
15	10042537	弯针调节摆杆	CRANK	1	1
16	10042538	弯针调节柱	SCREW	1	1
17	10042234	垫圈	WASHER	1	1
18	10042540	螺母	NUT	1	1
19	10042541	弯针防止挡接头	BLOCK PIN	1	1
20	10042542	垫圈	WASHER	1	1
21	10042543	偏心紧圈	COLLAR	1	1
22	10042513	螺钉	SCREW	1	1
23	10042544	螺母	NUT	1	1
24	10042545	弯针调节摆轴	SHAFT	1	1
25	10050347	挡圈	RING	1	1
26	10042518	垫圈	WASHER	1	1
27	10042533	弯针轴	SHAFT	1	1
28	10009399	油封	OIL SEAL	1	1

2.9 送布机构 FEED MECHANISM

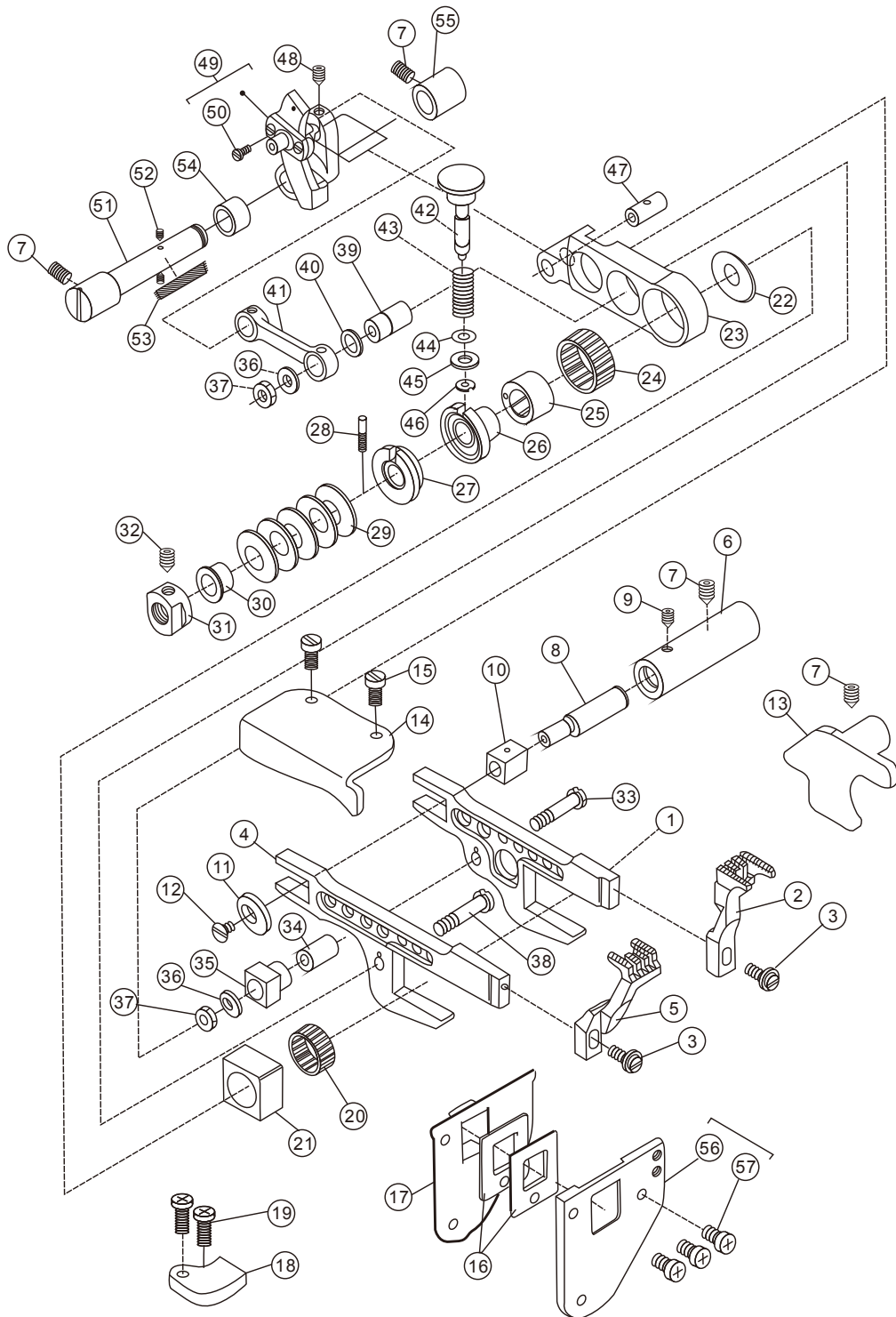

2.9 送布机构 FEED MECHANISM

序号 PEF NO	件 号 PART NO	名 称	DESCRIPTION	数量 QTY	
				562A	562A-BD
1	10042549	送料牙架	MAIN FEED BAR	1	1
2	*	主送布牙	MAIN FEED DOG	1	1
3	10042551	螺钉	SCREW	2	2
4	10042552	差动牙架	DIFFERENTIAL FEED BAR	1	1
5	*	差动送布牙	DIFFERENTIAL FEED DOG	1	1
6	10042554	偏心轴套	BUSHING	1	1
7	10042511	螺钉	SCREW	4	4
8	10042555	牙架偏心轴	ECCENTRIC PIN	1	1
9	10042556	偏心轴套螺钉	SCREW	1	1
10	10009633	滑块	GUIDE BLOCK	1	1
11	10042558	偏心垫片	WASHER	1	1
12	10042559	偏心轴螺钉	SCREW	1	1
13	10042560	牙架右限位板	RIGHT POSITION PLATE	1	1
14	10042561	牙架上限位板	UPPER POSITION PLATE	1	1
15	10042440	螺钉	SCREW	2	2
16	10011973	垫片	OIL SGIELD	1	1
17	10042564	垫板	COVER	1	1
18	10042565	左限位板	LEFT POSITION PLATE	1	1
19	10042412	螺钉	SCREW	2	2
20	10047403	滚针轴承	NEEDLE BEARING	1	1
21	10042567	牙架前滑块	BLOCK	1	1
22	10042568	凸轮送布连杆垫圈	WASHER	1	1
23	10042569	送布连杆	MAIN FEED LINK	1	1
24	10048638	滚针轴承	NEEDLE BEARING	1	1
25	10042571	凸轮	ECCENTRIC	1	1
26	10042572	送布调节凸轮	REGULATOR	1	1
27	10050150	针距调套	ECCENTRIC RETAINER	1	1
28	10043138	销螺钉	SCREW	1	1
29	10042574	碟形弹簧圈	SPRING	5	5
30	10042575	台阶套	SPACER	1	1
31	10042576	螺母	NUT	1	1
32	10042418	台阶套紧定螺钉	SCREW	1	1
33	10042577	送布滑块连接螺钉	SCREW	1	1
34	10042578	送布滑块套	BUSHING	1	1
35	10042579	送布滑块	GUIDE BLOCK	1	1

2.9 送布机构 FEED MECHANISM

序号 PEF NO	件 号 PART NO	名 称	DESCRIPTION	数量 QTY	
				562A	562A-BD
36	10042580	垫片	WASHER	2	2
37	10042581	螺母	NUT	2	2
38	10042582	连接螺钉	SCREW	1	1
39	10042583	送布连杆销套	BUSHING	1	1
40	10042584	开口挡圈	RING	1	1
41	10042585	差动送布连杆	DIFFERENTIC FEED LINK	1	1
42	10042586	针距按钮	PIN	1	1
43	10042587	针距按钮簧	SPRING	1	1
44	10042588	针距按钮 O 型圈	O RING	1	1
45	10042477	垫圈	WASHER	1	1
46	10009669	开口挡圈	RING	1	1
47	10042590	送布连杆销	RING	1	1
48	10042591	差动器紧定螺钉	SCREW	1	1
49	10042598	差动器组件	CRANK	1	1
50	10042524	差动器螺钉	SCREW	1	1
51	10042592	差动器轴	SHAFT	1	1
52	10008090	油线	OIL WICK	1	1
53	10008090	油线	OIL WICK	1	1
54	10042595	差动器隔套	SPACER	1	1
55	10042596	差动器轴套	BUSHING	1	1
56	10042597	弯针盖	BRACKET	1	1
57	10042394	螺钉	SCREW	3	3

2.10 差动调节机构 DIFFERENTIAL FEED MECHANISM

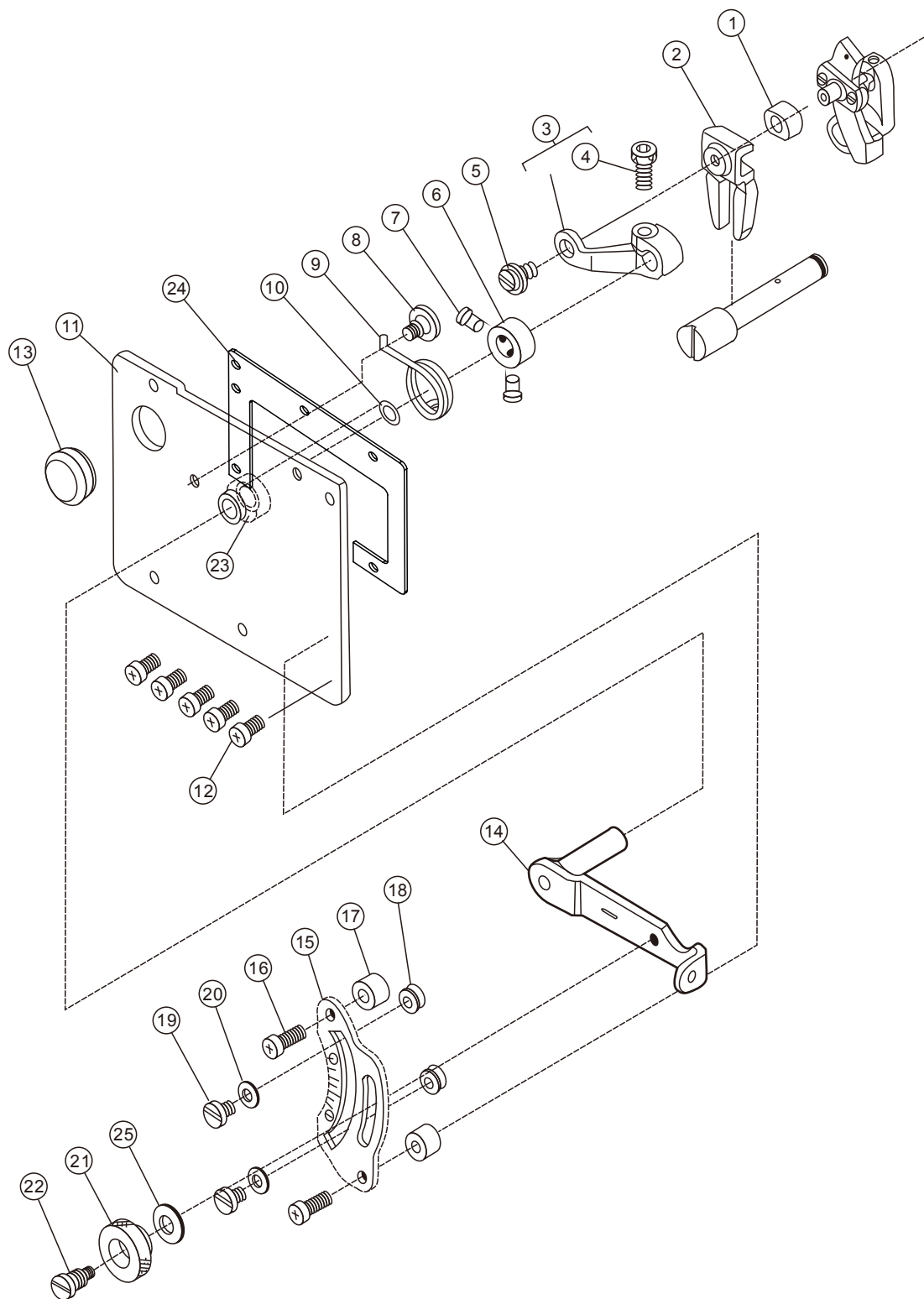

2.10 差动调节机构 DIFFERENTIAL FEED MECHANISM

序号 PEF NO	件号 PART NO	名称	DESCRIPTION	数量 QTY	
				562A	562A-BD
1	10042517	滑块	BLOCK	1	1
2	10042158	差动器吊板	GUIDE BLOCK	1	1
3	10042159	差动调节曲柄	LEWEW	1	1
4	10042160	差动调节曲柄螺钉	SCREW	1	1
5	10042161	差动调节吊板螺钉	SCREW	1	1
6	10042162	差动扳手紧圈	COLLAR	1	1
7	10043440	螺钉	SCREW	2	2
8	10042410	螺钉	SCREW	1	1
9	10042164	差动调节复位弹簧	SPRING	1	1
10	10042165	O 型圈	O RING	1	1
11	10042178	主板	BRACKET	1	1
12	10042394	螺钉	SCREW	5	5
13	10042166	闷头	PLUG	1	1
14	10042167	差动扳手	LEVER ASSEMBLY	1	1
15	10042468	差动刻度板	SCALE PLATE	1	1
16	10042387	螺钉	SCREW	2	2
17	10042169	刻度板隔套	SPACER	2	2
18	10042170	螺母	NUT	2	2
19	10042171	刻度板固定螺钉	SCREW	2	2
20	10042176	垫圈	WASHER	2	2
21	10042172	孔刻度板螺母	NUT	1	1
22	10042173	螺钉	SCREW	1	1
23	10042179	衬套	BUSHING	1	1
24	10042175	主板密封垫	GASKET	1	1
25	10042174	刻度盘垫片	WASHER	1	1

2.11 压脚结构 PRESSER FOOT MECHANISM

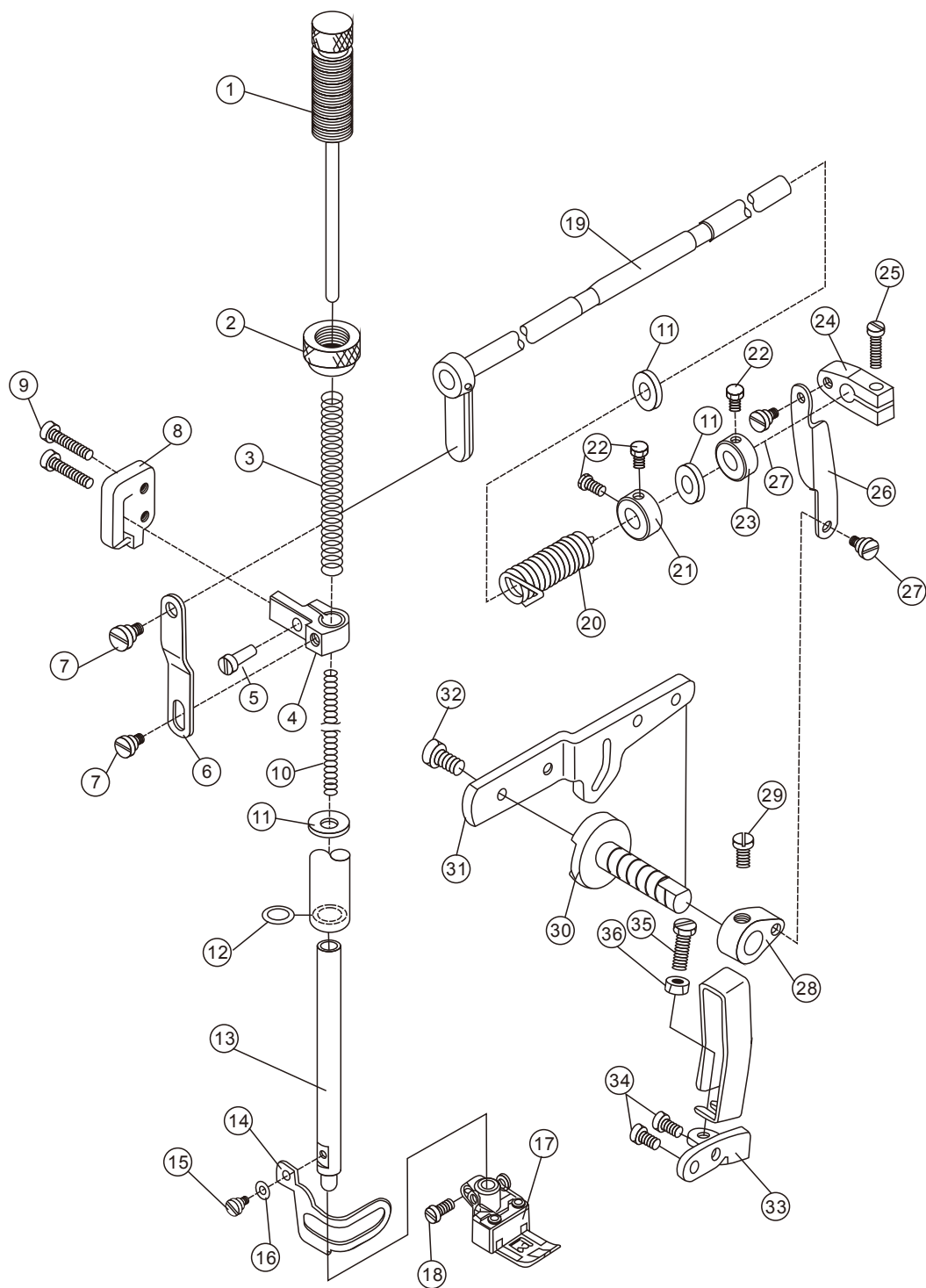

2.11 压脚机构 PRESSER FOOT MECHANISM

序号 PEF NO	件 号 PART NO	名 称	DESCRIPTION	数量 QTY	
				562A	562A-BD
1	10042180	调压螺钉	ADJUSTING BAR	1	1
2	10042181	调压螺母	NUT	1	1
3	10042182	调压外弹簧	SPRING	1	1
4	10042183	压紧杆导架	PRESSER BAR CLAMP	1	1
5	10042184	压紧杆导架螺钉	SCREW	1	1
6	10042185	抬牙脚吊杆	LINK	1	1
7	10042186	螺钉	SCREW	2	2
8	10042187	压杆导架座	GUIDE ASSEMBLY	1	1
9	10042188	螺钉	SCREW	2	2
10	10042189	调压内弹簧	SPRING	1	1
11	10011457	压紧杆防油罩	OIL GUARD	3	3
12	10042213	压紧杆油封	OIL SEAL	1	1
13	10042192	压紧杆	RESSER BAR	1	1
14	10042193	压紧防护罩	FINGER GUARD	1	1
15	10042194	压紧防护罩螺钉	SCREW	1	1
16	10042195	垫圈	WASHER	1	1
17	*	压脚组件	PRESSER FOOT ASSEMBLY	1	1
18	10042196	螺钉	SCREW	1	1
19	10042215	抬牙脚轴组件	LEVER	1	1
20	10042197	抬牙脚弹簧	SPRING	1	1
21	10042198	抬牙脚轴紧圈	COLLAR	1	1
22	10042513	螺钉	SCREW	3	3
23	10042199	限位紧圈	COLLAR	1	1
24	10042200	抬牙脚调节曲柄	BELL CRANG (UPPER)	1	1
25	10042201	螺钉	SCREW	1	1
26	10042202	抬牙脚吊板	LINK	1	1
27	10042203	螺钉	SCREW	2	2
28	10042204	吊杆曲柄	BELL CRANG (LOWER)	1	1
29	10042205	吊杆曲柄螺钉	SCREW	1	1
30	10042206	拉杆座	SHAFT	1	1
31	10042207	抬牙脚拉杆	LEVER	1	1
32	10042208	螺钉	SCREW	1	1
33	10042209	右限位板	BRACKET	1	1
34	10042394	螺钉	SCREW	2	2
35	10042210	螺钉	SCREW	1	1
36	10042540	螺母	NUT	1	1

2.12 绷针结构 SPREADER MECHANISM

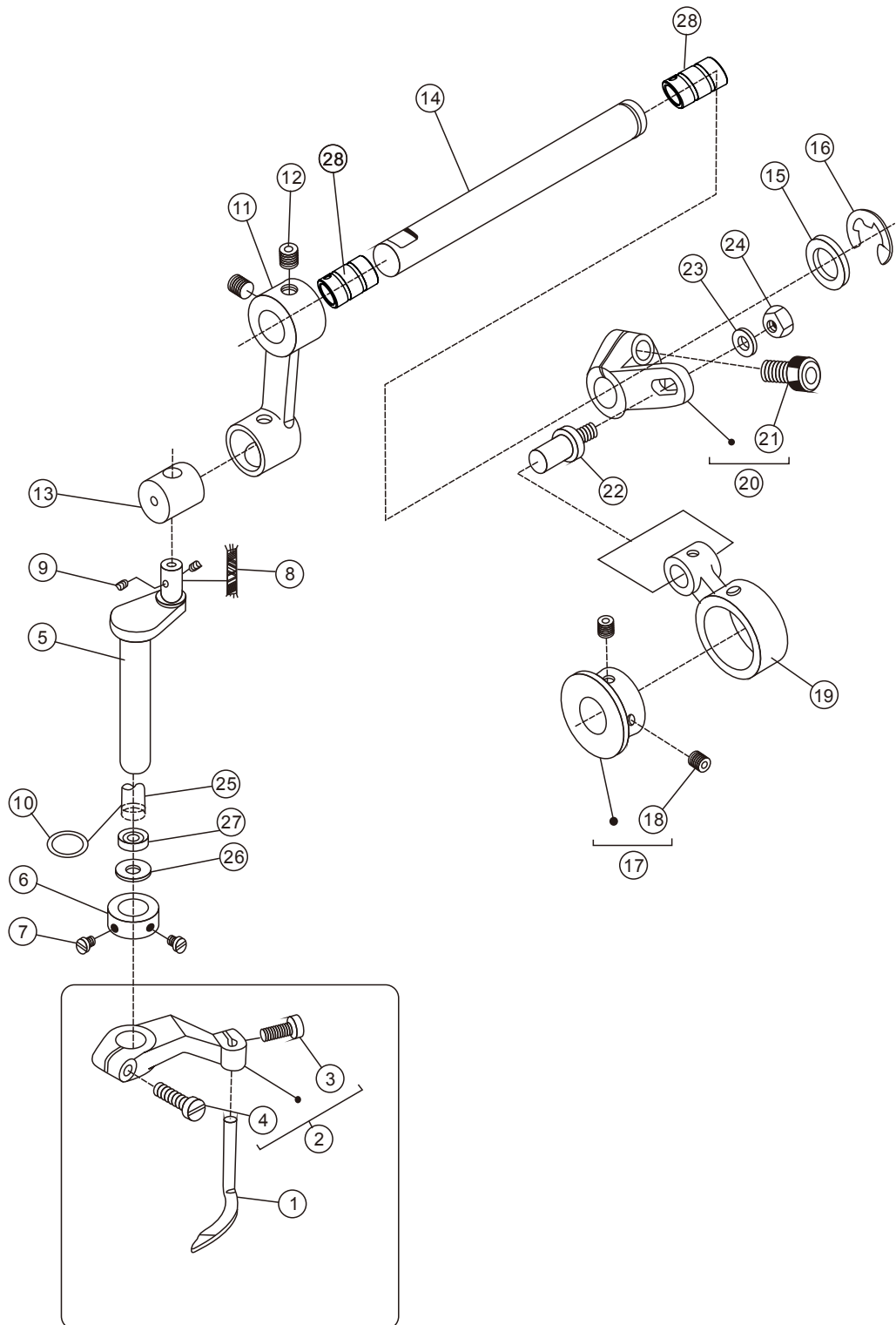

2.12 绷针机构 SPREADER MECHANISM

序号 PEF NO	件号 PART NO	名称	DESCRIPTION	数量 QTY	
				562A	562A-BD
1	10043140	绷针	SPREADER	1	1
2	10042218	绷针下摆杆	LEVER ASSEMBLY	1	1
3	10042412	螺钉	SCREW	1	1
4	10042219	绷针下摆杆紧定螺钉	SCREW	1	1
5	10042220	绷针曲柄	CRANK SHAFT	1	1
6	10042221	绷针紧圈	COLLER	1	1
7	10042406	螺钉	SCREW	2	2
8	10008090	油线	OIL WICK	1	1
9	10042223	油线	FELT	2	2
10	10042224	绷针竖轴 O 型圈	O RING	1	1
11	10042225	绷针上摆杆	CRANK	1	1
12	10042438	螺钉	SCREW	2	2
13	10042226	绷针连接柱	BLOCK	1	1
14	10042227	绷针横轴	SHAFT	1	1
15	10042228	绷针横轴垫圈	WASHER	1	1
16	10042229	开口挡圈	RING	1	1
17	10042230	绷针凸轮	ECCENTRIC ASSEMBLY	1	1
18	10042418	螺钉	SCREW	2	2
19	10042231	绷针连杆	CONNECTION	1	1
20	10042232	绷针调节摆杆	CRANK	1	1
21	10042434	绷针调节摆杆螺钉	SCREW	1	1
22	10042233	绷针调节螺钉	SCREW	1	1
23	10042234	绷针调节螺钉垫圈	WASHER	1	1
24	10042540	螺母	NUT	1	1
25	10042235	绷针竖套	BUSHING	1	1
26	10042237	绷针竖套油封垫圈	WASHER	1	1
27	10009399	绷针竖套油封	OIL SEAL	1	1
28	10042236	绷针横轴轴套	BUSHING	2	2

2.13 挺线及夹线机构 THREAD TENSION MECHANISM

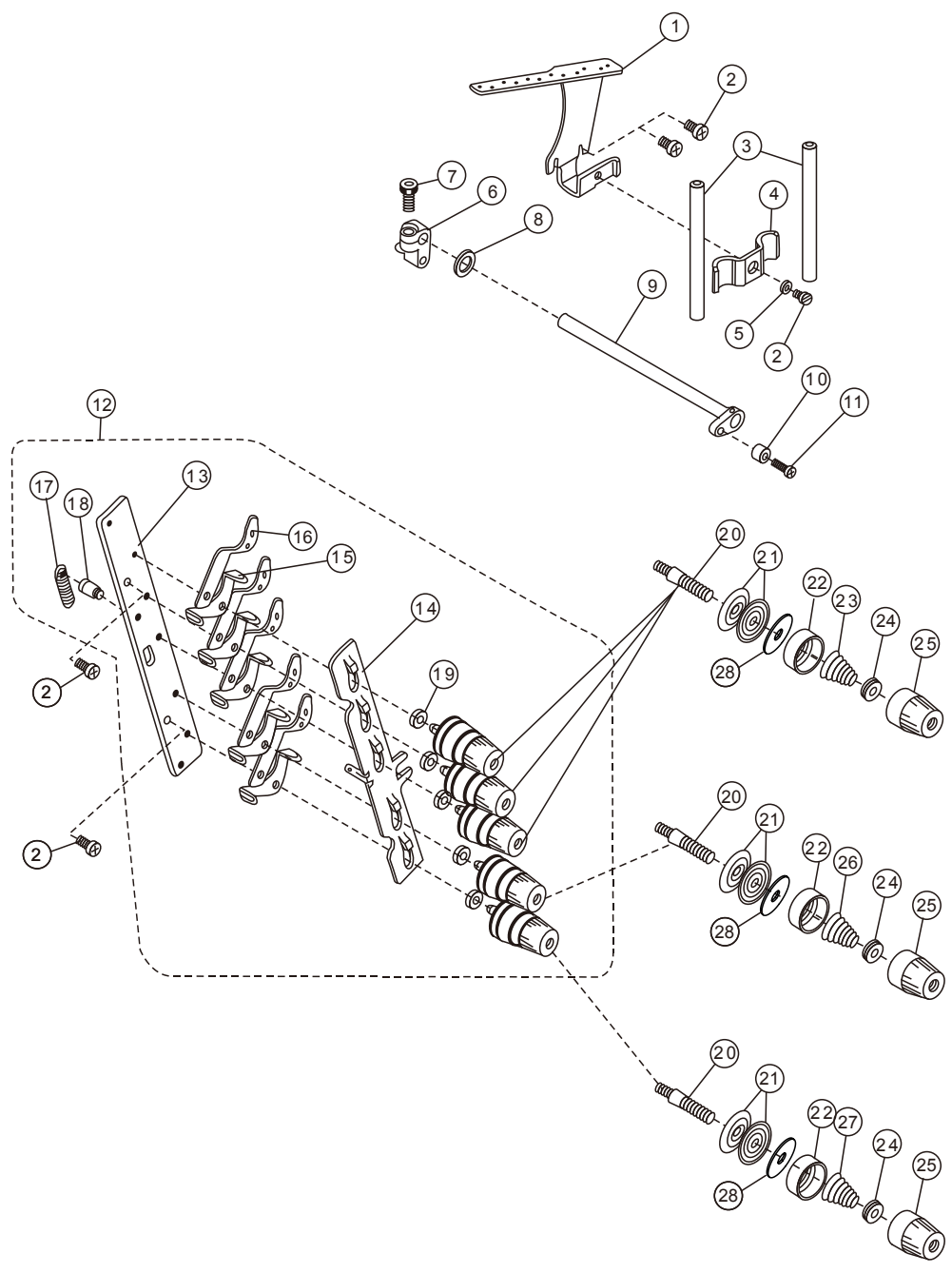

2.13 挺线及夹线机构 THREAD TENSION MECHANISM

序号 PEF NO	件号 PART NO	名称	DESCRIPTION	数量 QTY	
				562A	562A-BD
1	10042243	过线架	THREAD GUIDE	1	1
2	10042394	过线架螺钉	SCREW	5	5
3	10042244	过线管	PIPE	2	2
4	10042245	过线管压板	BRACKET	1	1
5	10003083	垫圈	WASHER	1	1
6	10042241	松线曲柄	CRANK	1	1
7	10042160	松线曲柄 螺钉	SCREW	1	1
8	10042242	垫圈	WASHER	1	1
9	10042238	挺线轴	SHAFT	1	1
10	10042239	隔套	SPACER	1	1
11	10042240	隔套螺钉	SCREW	1	1
12	10042247	五线过线板组件	TENSION CONTROL MECHANISM	1	1
13	10042248	挺线板	BRACKET	1	1
14	10042249	过线座	THREAD RELEASEA	1	1
15	10042252	压线过线板 2	THREAD GUIDE	5	5
16	10042253	夹线过线板 1	THREAD GUIDE	5	5
17	10042250	挺线扳拉簧	SPRING	1	1
18	10042251	挺线板螺钉	SCREW	1	1
19	10042254	垫圈	WASHER	5	5
20	10042255	夹线螺钉	SCREW	5	5
21	10042256	夹线板	TENSION DISC	10	10
22	10042257	夹线座	SPRING SHIELD	5	5
23	10042258	强夹线簧	SPRING(HEAVY)	3	3
24	10042261	夹线防松圈	RATCHET	5	5
25	10042262	夹线螺母	NUT	5	5
26	10042259	弱夹线簧	SPRING(MEDIUM)	1	1
27	10042260	中夹线簧	SPRING(LIGHT)	1	1
28	10051990	夹线板垫	WASHER	5	5

2.14 挑线机构 NEEDL& SPREADER THREAD MECHANISM

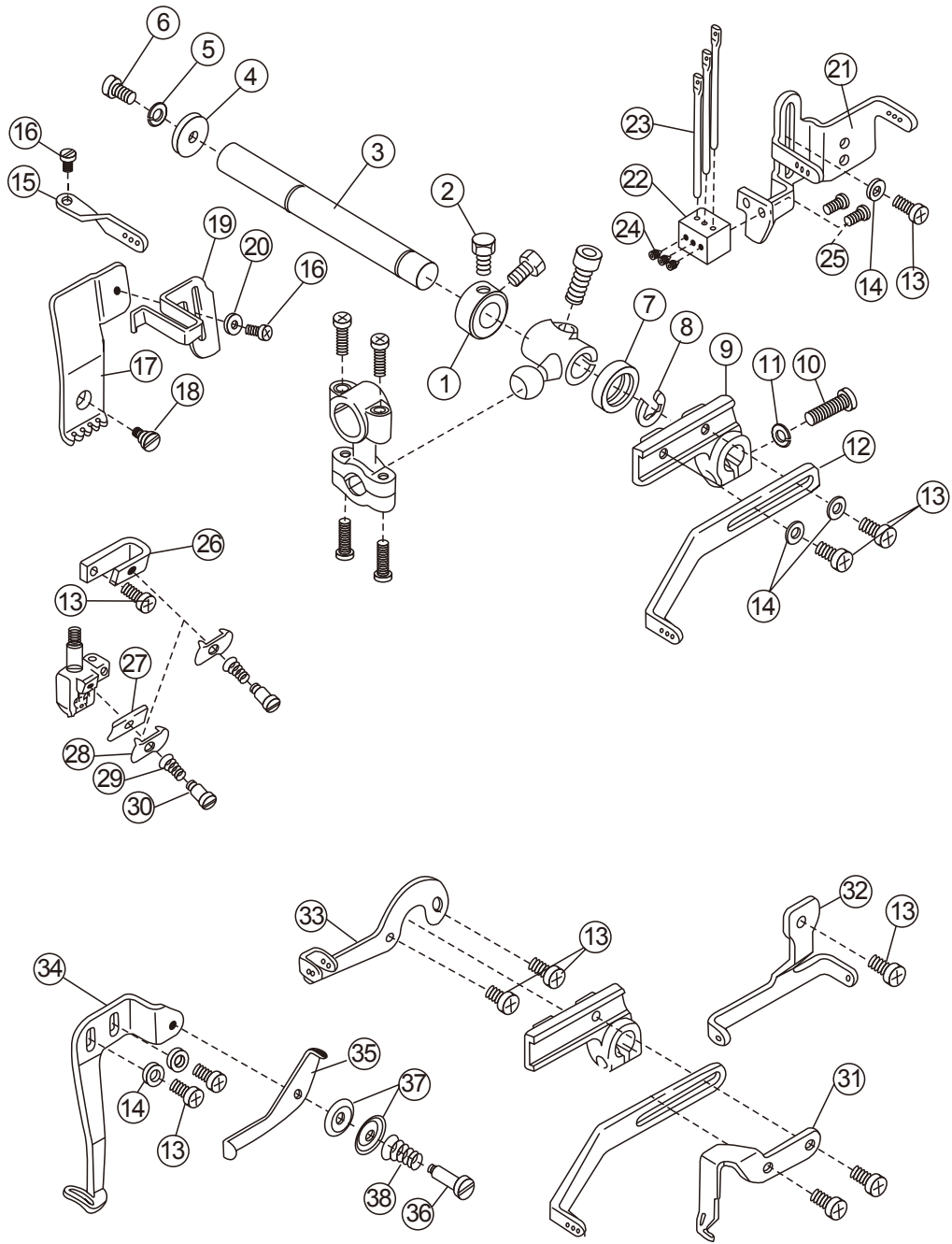

2.14 挑线机构 NEED& SPREADER THREAD MECHANISM

序号 PEF NO	件号 PART NO	名称	DESCRIPTION	数量 QTY	
				562A	562A-BD
1	10042263	挑线杆轴紧圈	COLLAR	1	1
2	10042264	挑线杆轴紧圈螺钉	SCREW	2	2
3	10042265	挑线杆轴	SHAFT	1	1
4	10042266	垫圈	WASHER	1	1
5	10042267	止退圈	WASHER	1	1
6	10042268	止退圈紧固螺钉	SCREW	1	1
7	10042532	密封圈	OIL SEAL	1	1
8	10042519	轴用开口挡圈	RING	1	1
9	10042269	挑线杆座	LEVER	1	1
10	10042478	挑线杆座夹紧螺钉	SCREW	1	1
11	10042522	止推垫圈	WASHER	1	1
12	10042270	挑线杆	THREAD TAKE-UP	1	1
13	10042394	螺钉	SCREW	9	9
14	10042413	垫圈	WASHER	5	5
15	10042271	针杆上过线勾	THREAD GUIDE	1	1
16	10042406	螺钉	SCREW	1	1
17	10042603	过线防护罩座	THREAD GUIDE	1	1
18	10042273	过线防护罩座螺钉	SCREW	1	1
19	10042604	挑线防护罩	THREAD SUPPORT	1	1
20	10042195	垫圈	WASHER	1	1
21	10042275	硅油过线座	THREAD GUIDE	1	1
22	10042276	过线钉座	HOLDER	1	1
23	10042277	过线钉	THREAD GUIDE	3	3
24	10042500	过线钉座紧定螺钉	SCREW	3	3
25	10042194	过线钉座固定螺钉	SCREW	2	2
26	10042278	小过线座	THREAD TENSION BRACKET	1	1
27	10042279	针扎过线板	THREAD GUIDE	1	1
28	10042280	针扎过线压板	THREAD RETAINER	1	1
29	10042281	针扎过线簧	SCREW	1	1
30	10042282	针扎过线螺钉	SCREW	1	1
31	10042283	上叉挑线杆	THREAD TAKE-UP	1	1
32	10042284	底线过线座	THREAD GUIDE	1	1
33	10042285	张线杆	THREAD GUIDE	1	1
34	10042286	绷线过线下过线板	THREAD GUIDE	1	1
35	10042287	绷线过线板	THREAD GUIDE	1	1
36	10042288	夹紧螺钉	SCREW	1	1
37	10042289	过线压板	THREAD RETAINER	2	2
38	10042290	压线簧	SPRING	1	1

2.15 打线凸轮机构 LOOPER THREAD MECHANISM

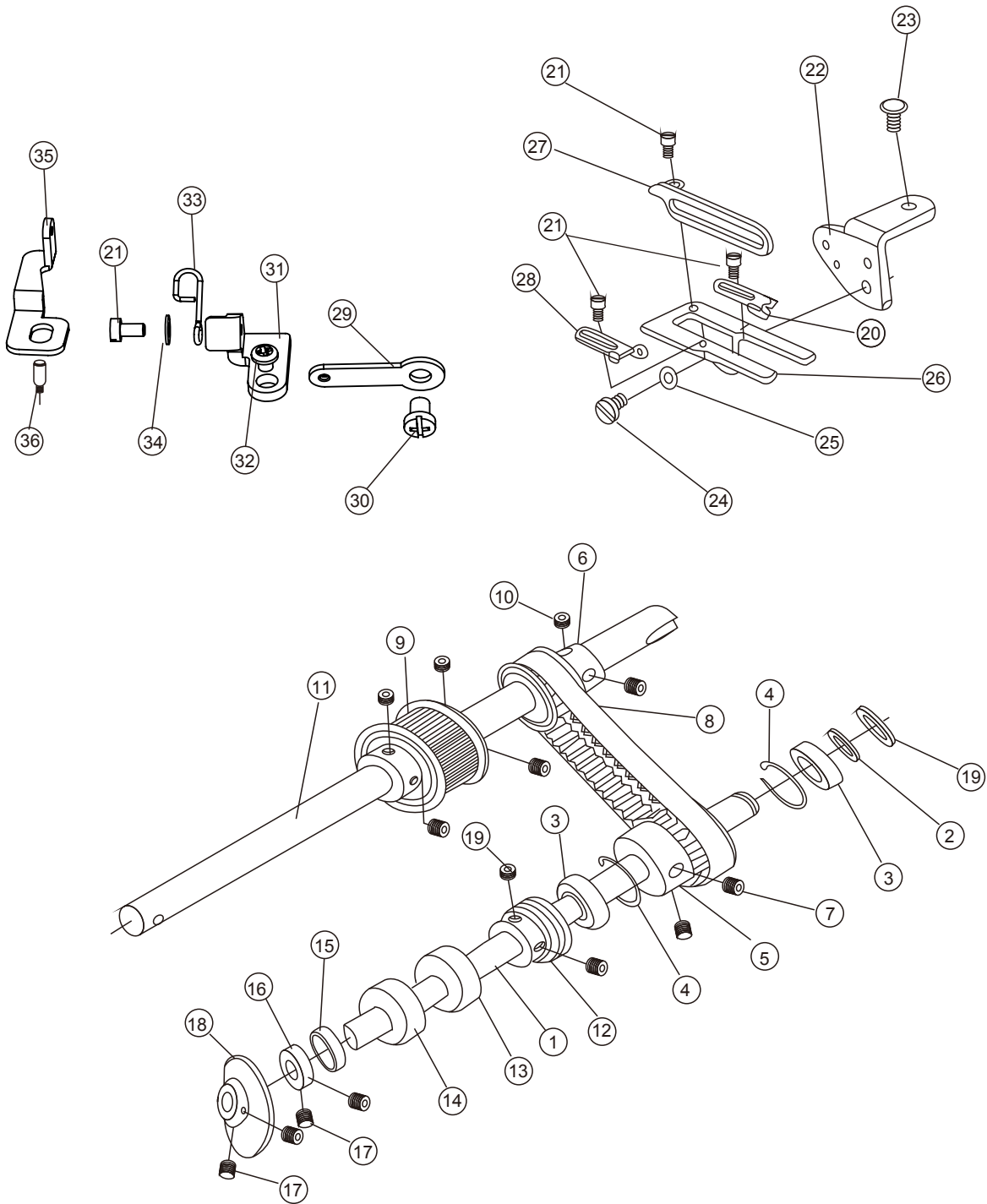

2.15 打线凸轮机构 LOOPER THREAD MECHANISM

序号 PEF NO	件号 PART NO	名称	DESCRIPTION	数量 QTY	
				562A	562A-BD
1	10042931	打线凸轮轴	SHAFT	1	1
2	10003334	挡圈	RING	1	1
3	10042938	轴承	BRACKET	2	2
4	10027925	挡圈	RING	2	2
5	10042907	打线从动同步带轮	SMALL GEAR 1	1	1
6	10042909	打线主动同步带轮	SMALL GEAR 2	1	1
7	10042438	螺钉	SCREW	2	2
8	10042912	同步带	TIMING BELT	1	1
9	10042910	主动同步带轮	GEAR	1	1
10	10042429	螺钉	SCREW	2	2
11	10043209	下轴后节	SHAFT	1	1
12	10042911	打线凸轮右衬套	GEAR SLEEVE (RIGHT)	1	1
13	10011204	油封	OIL SEAL	1	1
14	10042937	轴承	BRACKET	1	1
15	10042228	垫圈	WASHER	1	1
16	10042916	挡圈	RING	1	1
17	10042418	螺钉	SCREW	6	6
18	10042917	打线凸轮	THREAD TAKE-UP	1	1
19	10042922	骨架油封	PLUG	1	1
20	10042927	右穿线板	THREAD GUIDE (RIGHT)	1	1
21	10042406	螺钉	SCREW	4	4
22	10042924	过线板座	BRACKET	1	1
23	10042382	螺钉	SCREW	1	1
24	10042921	轴位螺钉	SCREW	1	1
25	10042913	波形垫圈	WASHER	1	1
26	10042928	过线板	BRACKET	1	1
27	10042929	过线压板	THREAD GUIDE (CENTER)	1	1
28	10042925	左穿线板	THREAD GUIDE (LEFT)	1	1
29	10042293	小过线板	BRACKET	1	1
30	10042402	螺钉	SCREW	1	1
31	10042926	弹簧钩座	SPRING HOOK SEAT	1	1
32	10042394	螺钉	SCREW	1	1
33	10042953	弹簧钩	SPRING HOOKS	1	1
34	10042195	垫圈	WASHER	1	1
35	10042294	过线板	BRACKET	1	1
36	10042400	底线过线柱	SCREW	1	1

2.16 润滑机构 (A) LUBRICATION MECHANISM (A)

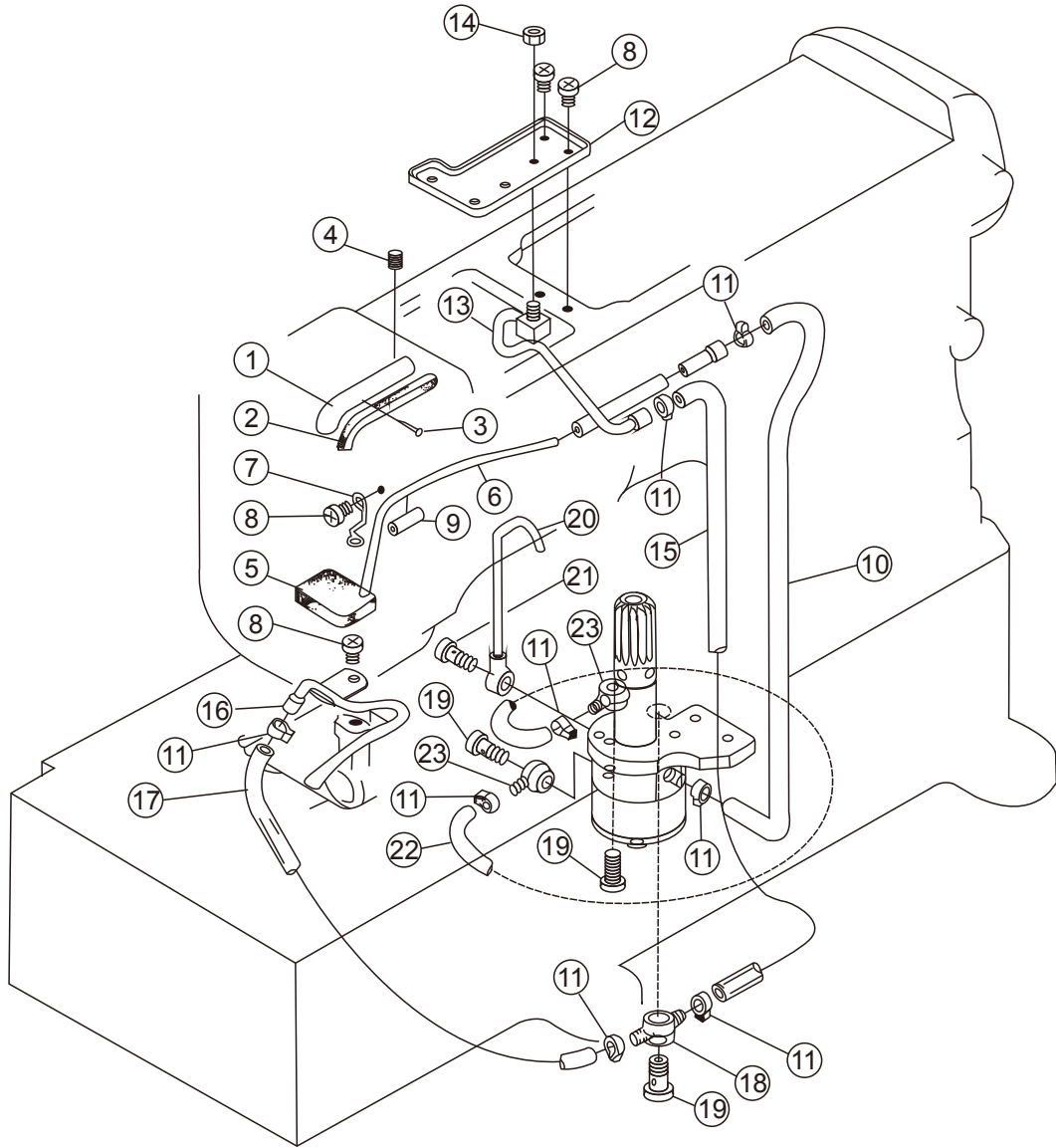

2.16 润滑机构(A) LUBRICATION MECHANISM(A)

序号 PEF NO	件号 PART NO	名称	DESCRIPTION	数量 QTY	
				562A	562A-BD
1	10042316	针杆曲柄过油管	OIL PIPE	1	1
2	10042317	针杆曲柄供油毡	FELT	1	1
3	10042318	油线钉	PIN	1	1
4	10042418	螺钉	SCREW	1	1
5	10051751	回油毡	FELT	1	1
6	10051752	回油铜管	PIPE	1	1
7	10052252	毛毡定位勾	LATCH	1	1
8	10042402	螺钉	SCREW	4	4
9	10007796	回油皮管	PIPE	1	1
10	10007796	回油皮管	PIPE	1	1
11	10011471	进油短油管夹	CLAMP	6	6
12	10042323	上油盘	OIL GUARD	1	1
13	10042324	上轴供油管	OIL DISTRIBUTOR	1	1
14	10042424	螺母	NUT	1	1
15	10007796	回油皮管	PIPE	1	1
16	10042326	下油管组件	OIL DISTRIBUTOR	1	1
17	10007796	回油皮管	PIPE	1	1
18	10012095	双通管接头	JOINT	1	1
19	10042329	螺钉双通油接头	JOINT SCREW	3	3
20	10042330	涡轮供油管组件	PIPE	1	1
21	10042331	螺钉小双通油接头	JOINT SCREW	1	1
22	10007796	回油皮管	PIPE	1	1
23	10012103	单通油管接头	JOINT	1	1

2.17 润滑机构 (B) LUBRICATION MECHANISM (B)

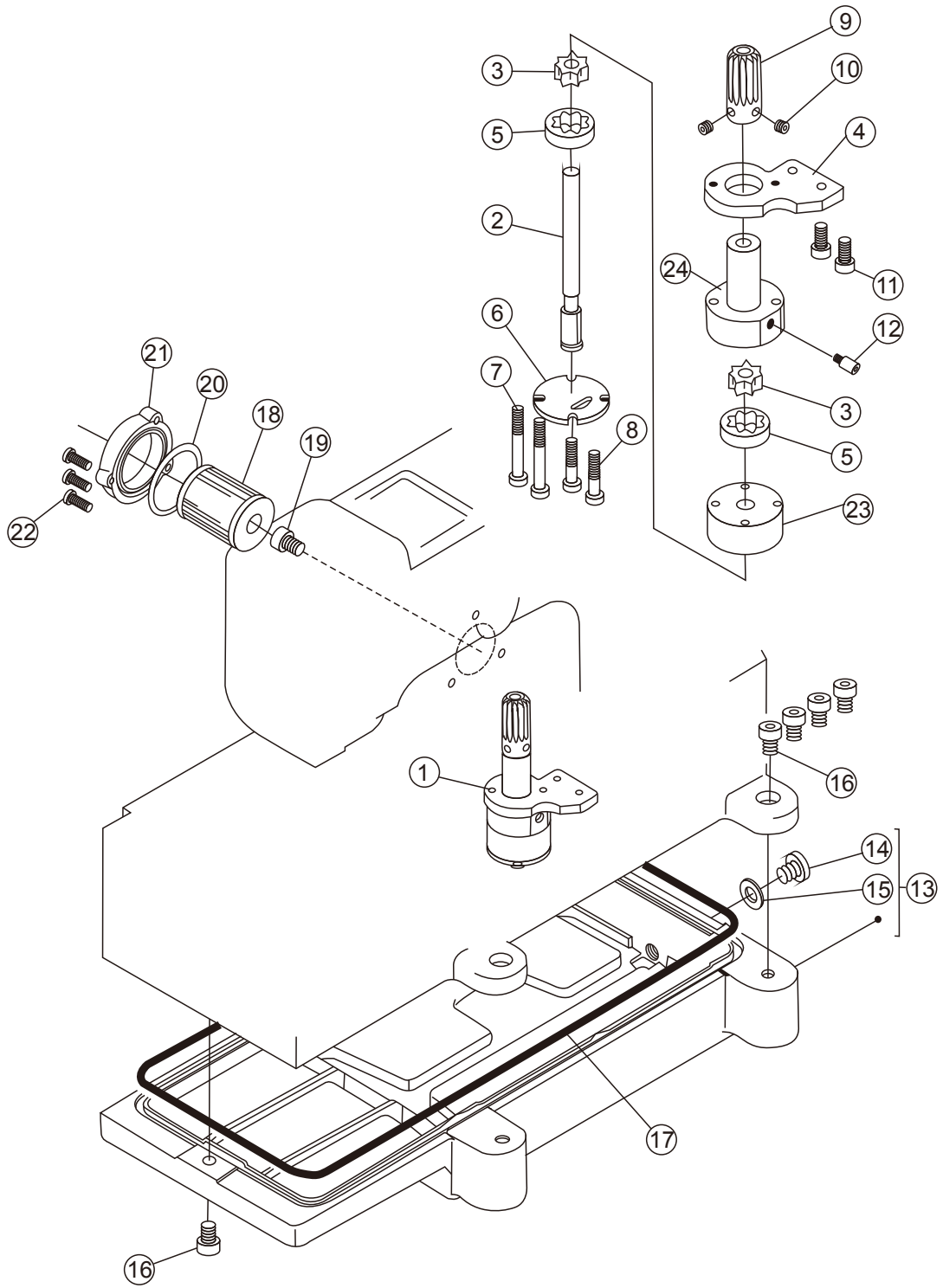

2.17 润滑机构(B) LUBRICATION MECHANISM(B)

序号 PEF NO	件号 PART NO	名称	DESCRIPTION	数量 QTY	
				562A	562A-BD
1	10042144	油泵组件	OIL PUMP ASSEMBLY	1	1
2	10042146	油泵轴	SHAFT	1	1
3	10042147	齿轮	ROTOR	2	2
4	10042145	固定板	SETTING BOARD	1	1
5	10042148	内齿轮	ROTOR	2	2
6	10042149	底板	COVER	1	1
7	10042150	长螺钉	SCREW	2	2
8	10042151	底板固定螺钉	SCREW	2	2
9	10042152	油泵涡轮	WORM WHEEL	1	1
10	10042418	螺钉	SCREW	2	2
11	10042160	固定板螺钉	SCREW	2	2
12	10042334	油泵回油管接头	JOINT SCREW	1	1
13	10042335	油盘	OIL RESERVOIR	1	1
14	10042336	油盘螺钉	SCREW	1	1
15	10042337	密封垫	WASHER	1	1
16	10042338	油盘下螺钉	SCREW	1	1
17	10042339	油盘防油垫	O RING	1	1
18	10043169	滤油器	FILTER ELEMENT	1	1
19	10042340	滤油器螺钉	SCREW	1	1
20	10042341	O型圈	O RING	1	1
21	10042342	滤油器盖	COVER	1	1
22	10042387	滤油器盖固定螺钉	SCREW	3	3
23	10042153	油泵壳体	OIL PUMP COVER	1	1
24	10042154	上油泵体	UPPER OIL PUMP	1	1

2.18 硅油盒机构 SILICON OIL RESERVOIR MECHANISM

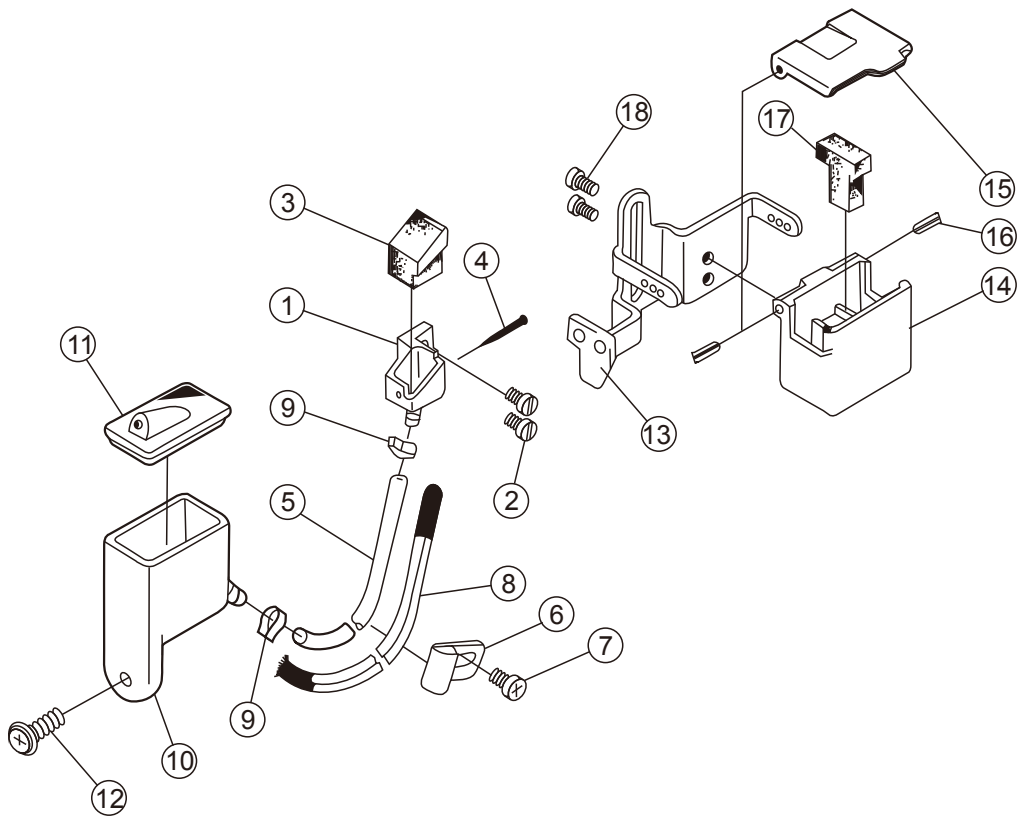

2.18 硅油盒机构 SILICON OIL RESERVOIR MECHANISM

序号 PEF NO	件 号 PART NO	名 称	DESCRIPTION	数量 QTY	
				562A	562A-BD
1	10042343	硅油盒壳体	NEEDLE COOLER (LOWER)	1	1
2	10042194	螺钉	SCREW	2	2
3	10042344	硅油盒毛毡	FELT	1	1
4	10042318	大头针	PIN	1	1
5	10007796	油管	TUBE	1	1
6	10042346	油线压板	BRACKET	1	1
7	10042377	螺钉	SCREW	1	1
8	10008095	油线	OIL WICK	1	1
9	10011471	夹头	CLAMP	1	1
10	10042347	硅油驻盒	SILICON OIL RESERVIOR (LOWER)	1	1
11	10042348	硅油驻盒盖	CAP	1	1
12	10042387	螺钉	SCREW	1	1
13	10042275	硅油过线座	THREAD GUIDE	1	1
14	10042350	上硅油盒	SILICON OIL RESERVIOR (UPPER)	1	1
15	10042351	上硅油盒盖	CAP	1	1
16	10044981	销	FIN	1	1
17	10042349	上硅油毡	FELT	1	1
18	10049820	螺钉	SCREW	2	2

2.19 线架 THREAD STAND

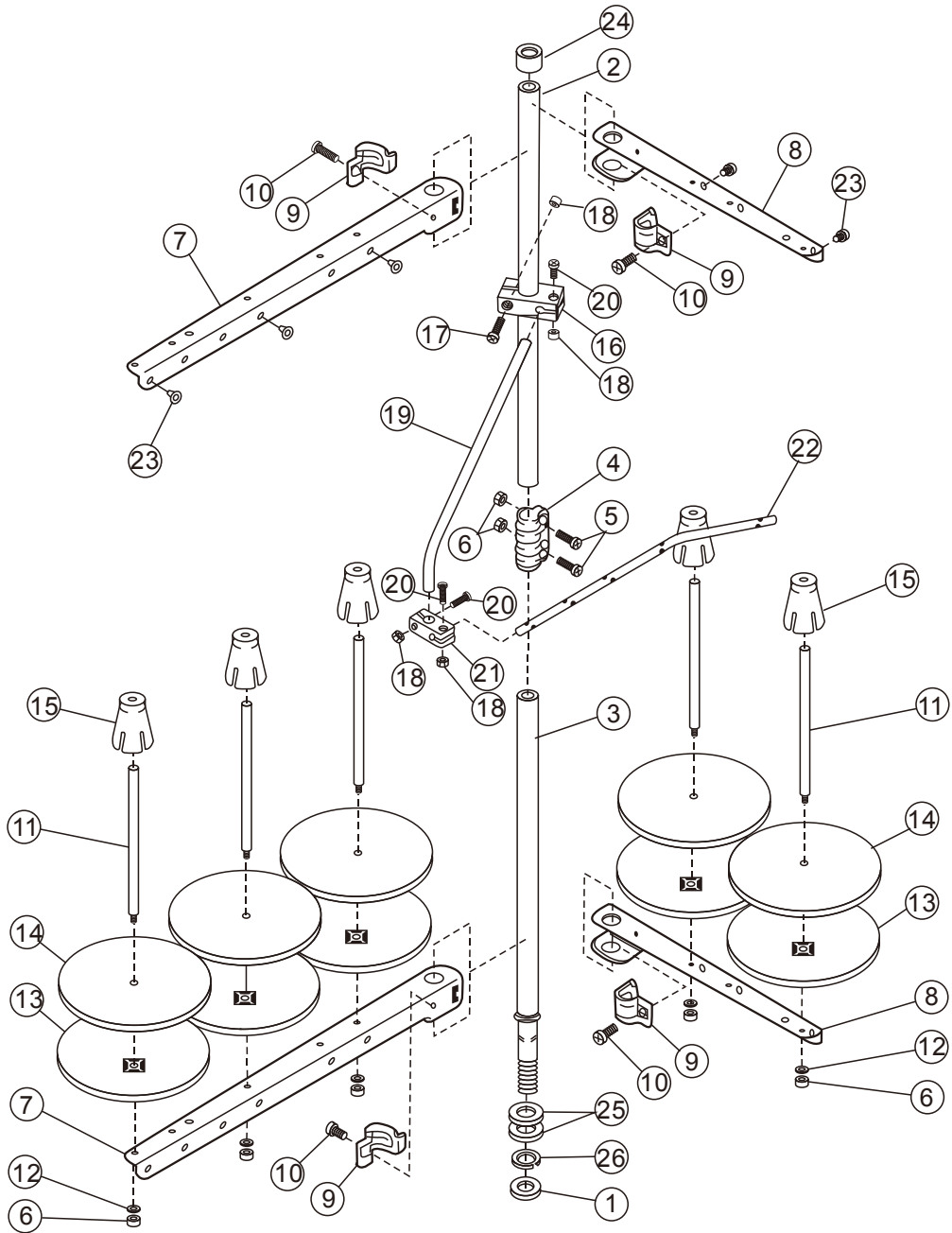

2.19 线架 THREAD STAND

序号 PEF NO	件号 PART NO	名称	DESCRIPTION	数量 QTY	
				562A	562A-BD
1	10046021	螺母	NUT	1	1
2	10045996	上过线管	THREAD BAR(UPPER)	1	1
3	10045997	下过线管	THREAD BAR(LOWER)	1	1
4	10045998	过线夹	JOINT	1	1
5	10045999	螺钉	SCREW	2	2
6	10046000	螺母	NUT	7	7
7	10046001	上过线架	BRACKET	2	2
8	10046002	前过线架	BRACKET	2	2
9	10046003	夹子	HOLDER	4	4
10	10046004	螺钉	SCREW	4	4
11	10046005	线团固定柱	SPOOL PIN	5	5
12	10046006	弹簧垫圈	SPRING WASHER	5	5
13	10046007	线盘	SPOOL TRAY	5	5
14	10046008	线盘垫	SPOOL MAT	5	5
15	10046009	定心座	SPOOL PETAINING	5	5
16	10046010	中过线板夹紧块	BRACKET	1	1
17	10046011	螺钉	SCREW	1	1
18	10046012	螺母	NUT	4	4
19	10046013	中过线接杆	THREAD GUIDE BAR	1	1
20	10046014	螺钉	SCREW	3	3
21	10046015	中过线接头	BRACKET	1	1
22	10046016	中过线杆	THREAD GUIDE BAR	1	1
23	10046017	过线管	THREAD GUIDE	5	5
24	10046018	上立柱橡皮封	RID CAP	1	1
25	10046019	垫圈	WASHER	2	2
26	10046020	弹簧垫圈	SPRING WASHER	1	1

2.20 台板及附件 MACHINE SUPPORTING MECHANISM

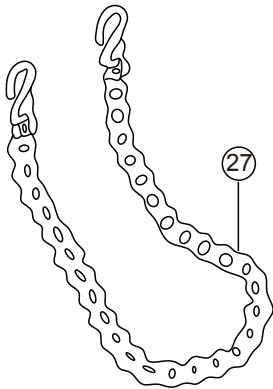
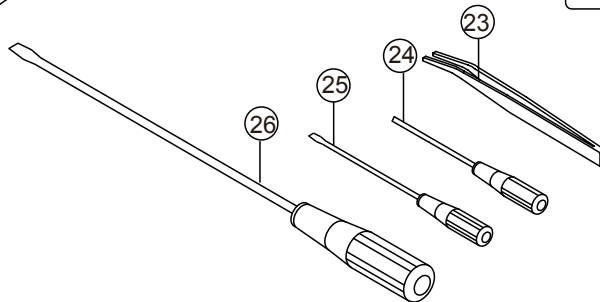
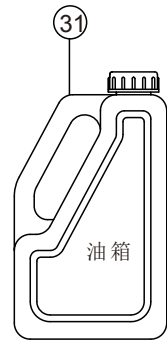
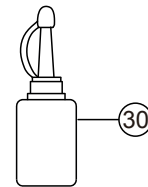
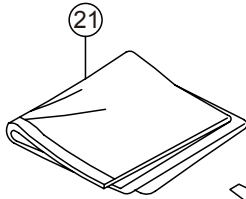
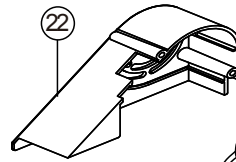
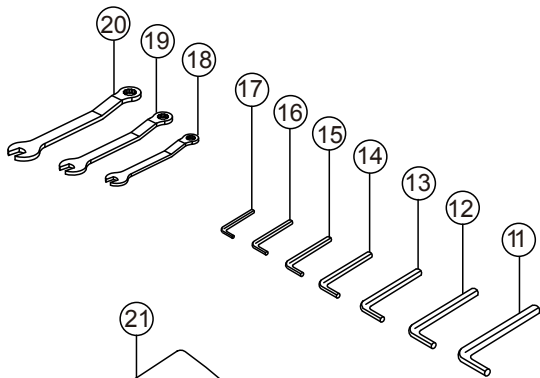
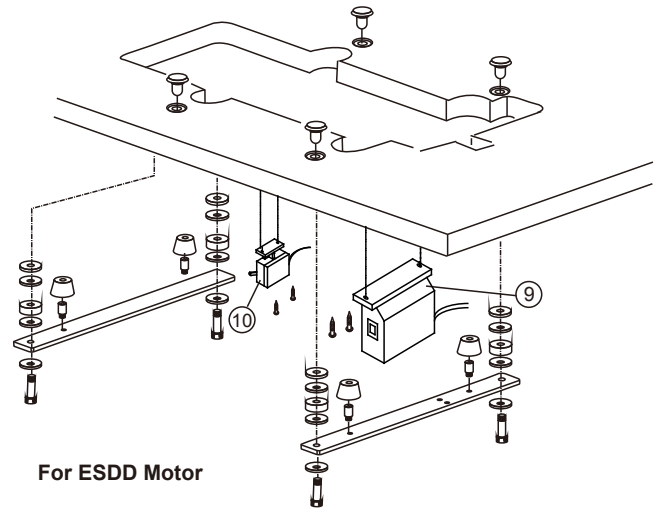
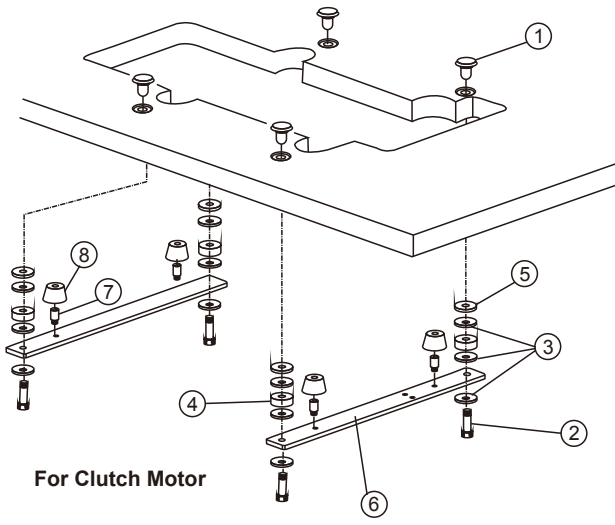

2.20 台板及附件 MACHINE SUPPORTING MECHANISM

序号 PEF NO	件 号 PART NO	名 称	DESCRIPTION	数量 QTY	
				562A	562A-BD
1	10042353	台板螺钉	SCREW	4	4
2	10042354	长螺钉	BOLT	4	4
3	10042355	垫片	WASHER	12	12
4	10042356	大胶垫	SPACER	4	4
5	10042357	小胶垫	SPACER	4	4
6	10042358	承重板	REST BOARD	2	2
7	10042359	螺钉	SCREW	4	4
8	10042360	承重板胶垫	RUBBER CUSHION	4	4
9	10050653	绷缝三自动电控	ESDD CONTROL BOX ASSEMBLY	0	1
10	10042950	踏板控制器	SCREW	0	1
11	10009688	内六角扳手 6mm	ALLEN KEY 6mm	1	1
12	10009689	内六角扳手 5mm	ALLEN KEY 5mm	1	1
13	10009687	内六角扳手 4mm	ALLEN KEY 4mm	1	1
14	10043163	内六角扳手 3.5mm	ALLEN KEY 3.5mm	1	1
15	10009685	内六角扳手 3mm	ALLEN KEY 3mm	1	1
16	10009686	内六角扳手 2.5mm	ALLEN KEY 2.5mm	1	1
17	10009683	内六角扳手 2m	ALLEN KEY 2mm	1	1
18	10014185	扳手 6	WRENCH KEY (6)	1	1
19	10014122	扳手 7	WRENCH KEY (7)	1	1
20	10014186	扳手 8	WRENCH KEY (8)	1	1
21	10011311	机头罩☆	DUST COVER☆	1	1
22	10047361	皮带罩组件	BELT COVER ASSEMBLY	1	0
23	10004247	镊子组件	TWEEZERS	1	1
24	10009270	内六角开刀	SCREW DRIVER	1	1
25	10010995	中螺丝刀	SCREW DRIVER	1	1
26	10010994	大螺丝刀	SCREW DRIVER	1	1
27	20000813	踏板链条组件	CHAIN ASSEMBLY	1	1
28	10050369	UY128GAS 11#机针	NEEDLE #11	3	3
29	10045181	说明书☆	INSTRUCTION MANUAL☆	1	1
30	10011155	硅油瓶	OILER	1	1
31	10004455	油箱	IOL POUCH	1	1

2.21 卷边专用件 FOLDER ASM

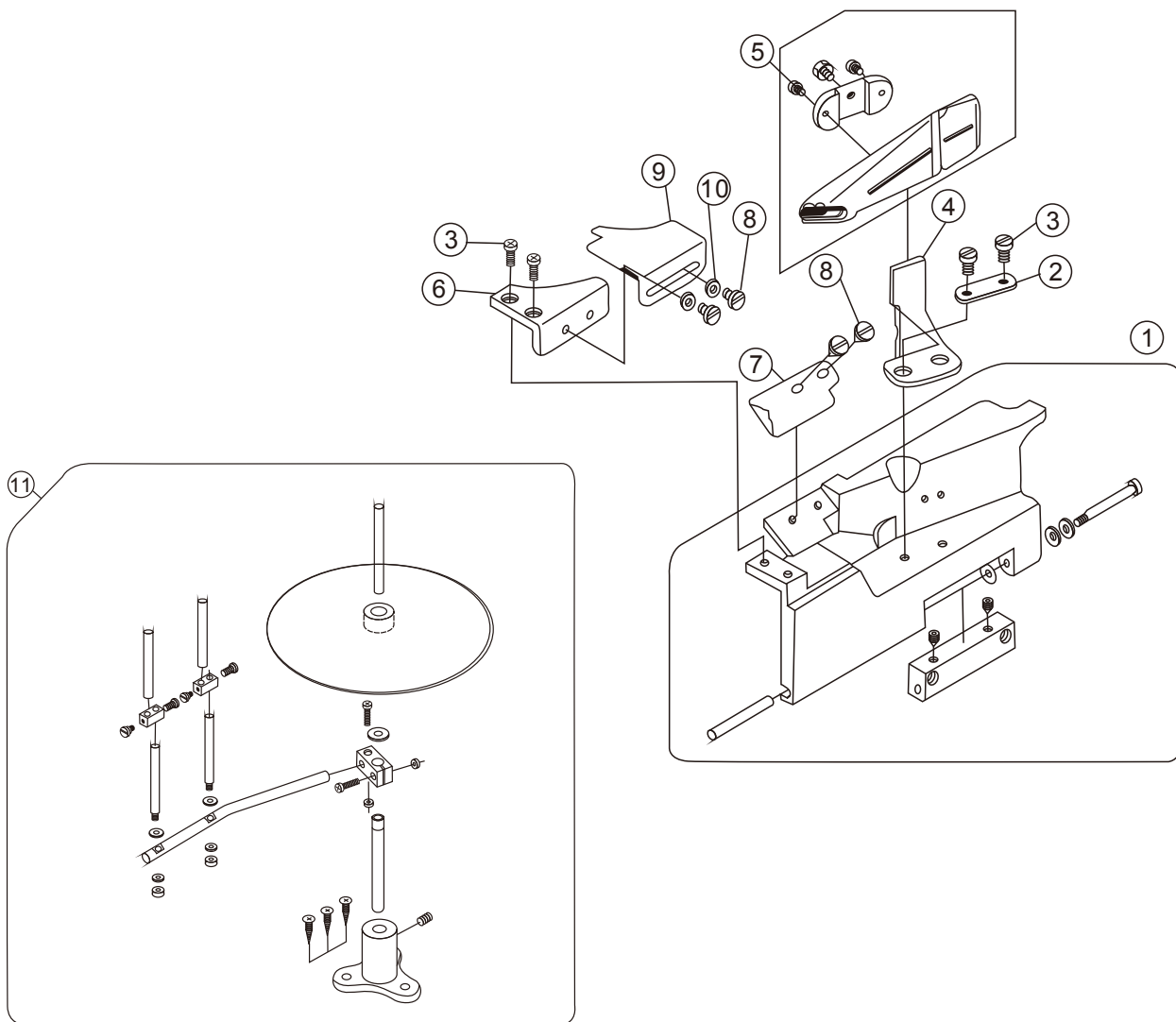

2.21 卷边专用件 FOLDER ASM

序号 PEF NO	件 号 PART NO	名 称	DESCRIPTION	数量 QTY	
				562A	562A-BD
1	10042955	穿线罩组件	FRONT COVER ASSEMBLY	1	1
2	10042863	卷便器支架垫片	WASHER	1	1
3	10042481	螺钉	SCREW	4	4
4	10042862	卷边器支架	BRACKET	1	1
5	10045989	卷边器组件	FOLDER ASSEMBLY	1	1
6	10042864	穿线罩板上板	FRONT COVER (SMALL)	1	1
7	10042867	挡料板	FABRIC GUARD	1	1
8	10042865	穿线罩板上板螺钉	SCREW	4	4
9	10042866	引布板	AUXILLARY PLATE	1	1
10	10042477	垫片	WASHER	2	2
11	10045990	托料盘组件	TAPE GUIDE ASSEMBLY	1	1



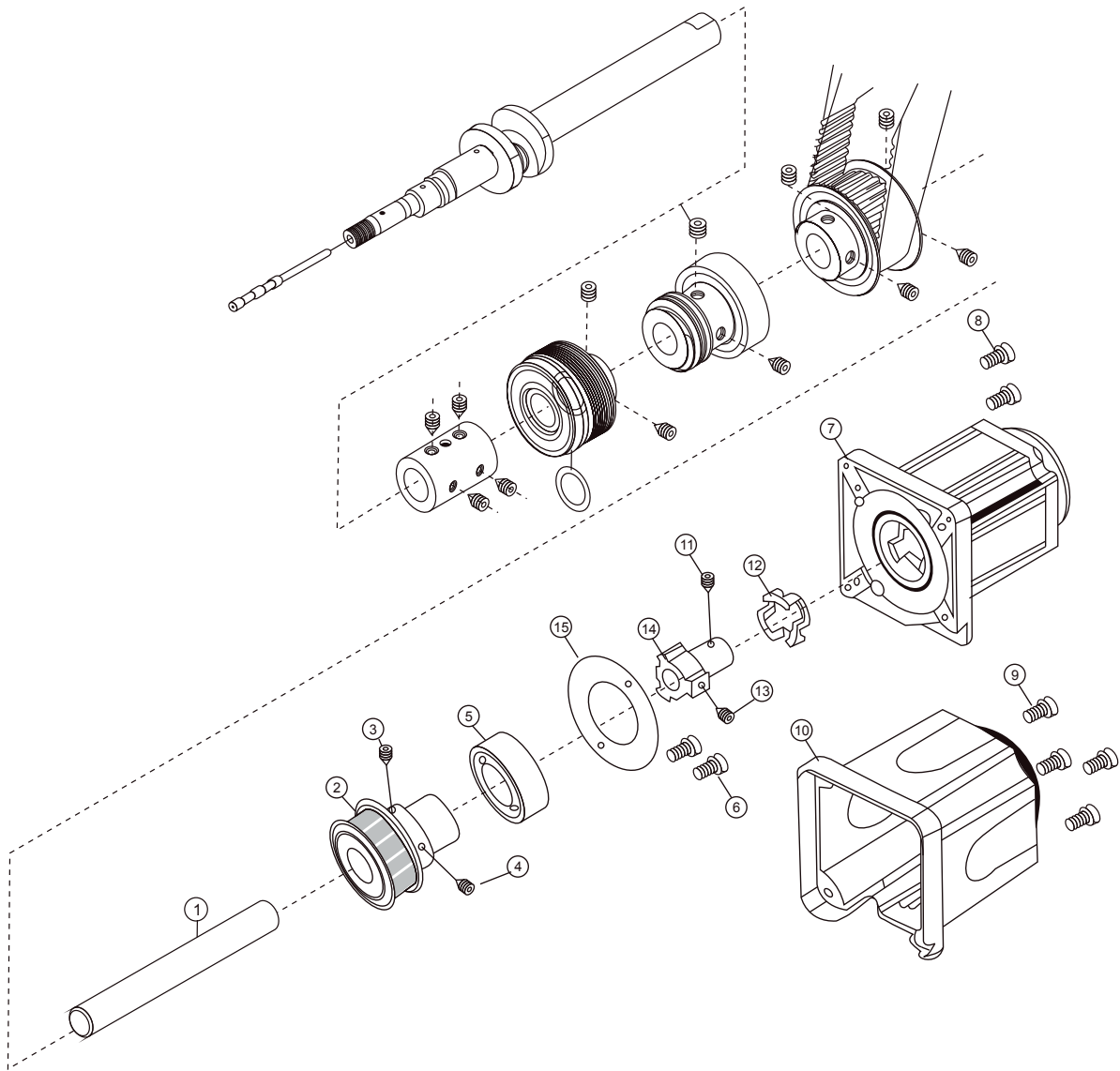







2.22 直驱电机结构 ESDD MOTOR COMPONENTS



2.22 直驱电机结构 ESDD MOTOR COMPONENTS

序号 PEF NO	件号 PART NO	名称	DESCRIPTION	数量 QTY	
				562A	562A-BD
1	10043209	下轴后节	SHAFT	0	1
2	10042909	打线主动同步带轮组件	GEAR	0	1
3	10042437	螺钉	SCREW	0	1
4	10042438	螺钉	SCREW	0	1
5	10042466	轴承	BEARING	0	1
6	10042440	螺钉	SCREW	0	2
7	10044432	直驱马达	DIRECT DRIVE MOTOR ASSEMBLY	0	1
8	10044437	螺钉	SCREW	0	4
9	10042387	螺钉	SCREW	0	4
10	10044438	电机罩	MOTOR COVER	0	1
11	10042437	联轴器定位螺钉	SCREW	0	1
12	10044441	电机联轴器	MOTOR COUPLING	0	1
13	10042437	螺钉	SCREW	0	1
14	10042436	联轴器	COUPLING	0	1
15	10042439	压紧圈	CLAMPING RING	0	1

2.23 针位互换清单 GAUGE PARTS LIST

规格件表					CONVERSION CHART				
									
MODEL	SUB-CLASS	NEEDLE CLAMP	NEEDLE PLATE	MAINFEED DOG	KIFF. FEED DOG	PRESSER FOOT	SPREADER	LOOPER	NEEDLE
机型	规格	针夹	针板	主送料牙	差动送料牙	压脚	绷针	弯针	针号
562-1-356	356	10042499	10042501	10042550	10042553	10042214	10043140	10043133	UY128GBS 11#
562-1-364	364	10043126	10043127	10042550	10042553	10043128			
562-2-356	356	10042499	10042868	10042869	10042870	10046045			
562-2-364	364	10043126	10043052	10042869	10042870	10045988			UY128GAS 14#
562XL-1-356	356	10042499	10047317	10047315	10044450	10011368			UY128GBS 11#
562XL-2-356	356	10042499	10044466	10044469	10044470	10046045			
562-1-356S	356	10042499	10050461	10042550	10042553	10042214			