

1. Safety operating guide

- 1) When turning the power on, keep your hands and fingers away from the area under the needle and around the pulley.
- 2) Power must be turned off when the machine is not used or when the operator leaves his/her seat.
- 3) Power must be turned off when incline the machine head, install/remove the belt or move machine.
- 4) Don't place finger, hair, shaft etc. near pulley, belt, wheel and motor in order to avoid injury.
- 5) Don't insert finger into the thread take up lever guard cover, keep your hands and fingers away from the area under the needle and around the pulley when the machine is in operation.
- 6) Don't operate the machine without the safety devices if the belt cover or eye guard are installed.

2. Operating notice

- 1) Don't operate the machine if the oil tank without full oil.
- 2) The machine adopt semi-automatic lubricating mode. Don't operate the machine before lubricating.
- 3) Check the rotation direction of pulley when firstly start new machine. (The pulley should rotate in counterclockwise when viewed from pulley)
- 4) Check the voltage and phase. (Single or three whether is corresponds with the data in motor nameplate)

3. Operating condition

- 1) Avoid using machine at abnormally high temperature (40°C or higher) or low temperature (5°C or lower). Otherwise machine failure may result.
- 2) Avoid using machine in dusty condition.

4. Chief specification

Specification	Model	AK-82800	AK82800-GD
Max sewing speed (rmp)		2800	
Stitch length (mm)		0-5	
Stitch width (mm)		0-10	
Needle bar stroke (mm)		36	
Take-up lever stroke (mm)		82	
Needle		DPx17 Nm90-120	
Feed dog height (mm)		1.2	
Presser foot lift	height (mm)	8	
	By hand (mm)	10	
Hook		Semi-lubricating and trinal thread capacity	
Lubricating mode		Semi-automatic lubricating	
Trimming device		Without	With
Motor		Clutch motor 370W	Servo motor 550W

5. Power cable connection

- 1) When connecting the power cable to control box, it should confirm the connector type and machine direction firstly and then plug the connector into proper receptacle completely.
- 2) Rotary direction: Please refer the instruction book of connected motor if it needs to change the rotary direction of motor.

6. Control box connection

The control box should be connected as shown in fig.1.

Note:

- (1) Be sure to turn the power switch off for safety before connecting or disconnecting the connector.
- (2) Machine type must suit for control box of motor.

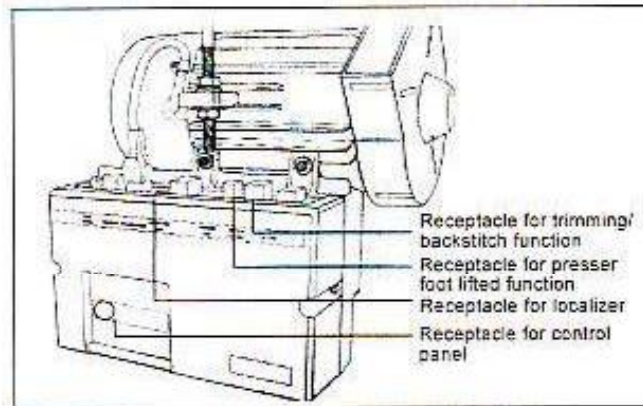

Fig.1

7. Install belt(Fig.2)

- 1) Use V-belt which special for sewing machine.
- 2) To adjust the tension of belt. Change the height of motor through turn the tension adjustive nut. It is ok if the belt can be sink inside with 15mm when pressing the center position of belt surface. Lacking tension will cause unstable running speed of machine, or needle stand at wrong stop position when machine in middle/ slow running condition. Excessive tension will cause the motor bearing be damaged.

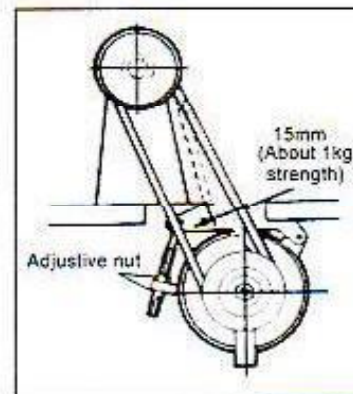

Fig.2

8. Install belt cover

It must install belt cover for machine head and motor for safety.

9. The needle bar stop position adjustment

Note: It adopts outside localizer, please refer the instruction book of connected motor for the adjustment method.

1) "Up" Position

When the pedal is kicked down by heel, the machine should stop at "Up" position, i.e. the highest position of take-up lever.

2) "Down" Position

When the pedal is stand at middle position, the machine should stop at "Down" position, i.e. the needle bar raises 3mm from its lowest position.

10. Operation guide (motor and control box)

- 1) Keep foot away from pedal when turn on/off the power. Power must be turned off when the operator leaves his/her seat.
- 2) The detent can't work when the power is interrupted or power failure occurs during the machine operation.
- 3) Keep the control box cover is closed during operation in order to avoid accidental operation since the dust come into control box.
- 4) Must use multimeter to check control loop circuit in order to protect the semiconductor parts.
- 5) Power must be turned off when incline machine head only or touch needle.
- 6) Must use earthing cable (with yellow/green color) to connect motor.
- 7) When check the inter circuit, it must turn off the power firstly and then open the front cover.
- 8) It must wait 10 minutes after turn off the power due the high voltage in box. (It is very importance to release the inside energy.)
- 9) Keep motor away from much noise area such as high frequency joint area when use it

11. To lubricate the machine

Clean the machine completely before operate it daily, and check the oil quantity of hook oil tank. Then inject oil as arrow shows in fig.3 and fig.4, start operation of machine.

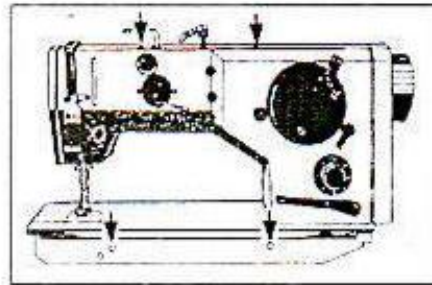

Fig.3

12. The hook lubricating condition adjustment(Fig.4)

To adjust hook lubricating through screw A which site before oil tank of hook.

- 1) The oil quantity is lowest when screw A was turned with clockwise and the arrow points to "0" position.
- 2) The oil quantity is highest when screw A was turned with anticlockwise and the arrow points to "MAX" position.

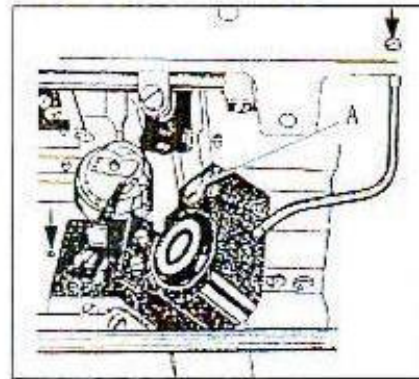

Fig.4

13. Time machine cleaning

The hook, feed dog and other parts of machine should be cleaned daily, and drop two or three coal oil into hook and other place that need to be lubricated. Clean all the spilth after ending of highest speed operation of machine, then lubricate the machine with oil. The clean work must be insisted every day. (Especially the machine worked one week, the clean work is very importance. Or the spilth will affect the sewing capability and rust hook and machine. It should to take away bobbin from hook before cleaning.)

Maintenance of motor: Clean dust of the motor cover each one or two month. (More dust or sundries of motor cover will make it too heat.)

Maintenance of control box: Clean dust of the connector. (It will affect accidental operation if there is more dust on the connector.)

Warning:

Before proceeding to clean and librating the machine, be sure to switch off all switches and hold your feet away from the machine stand pedal in order to avoid accidental machine start by pedal actuation.

14. Wind the bobbin(Fig.5)

1) Inside winder (Fig.5)

Pass the thread through the thread guide (6) from the thread stand, wind it few times anticlockwise on the bobbin and put the bobbin on the winder shaft (1). Switch on the motor and depress the treadle lightly to start the machine and by this winder as well. The winding amount (See Fig.6) is 80% of full capacity. It can be adjusted by loosening the screw (4) of the control lever (5) mounted on the disconnecting pin (3). When the winding is completed, using the knife mounted in the spring (2) cut off the thread end.

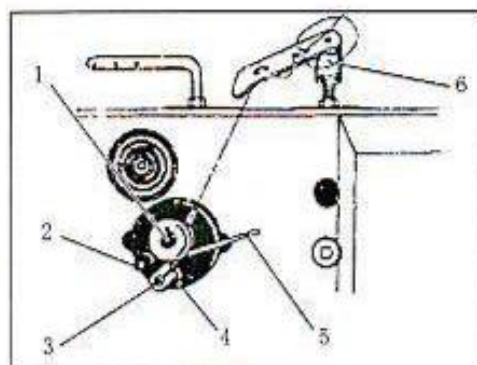

Fig.5

2) Outside winder (Fig.6)

Thread tension: Slack winding is recommended for polyester and nylon thread.

Amount of wound thread: Move the thread guide toward smaller diameter of wound thread layer.

Capacity of wound thread: Loosen the adjust screw to decrease the amount of wound thread. Vice versa.

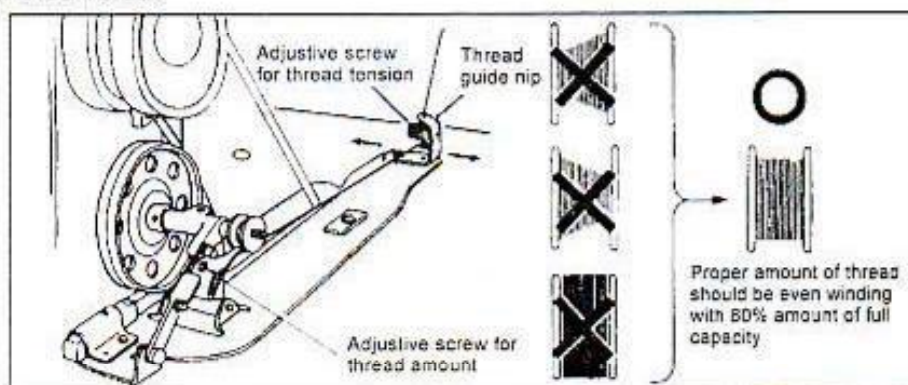

Fig.6

15. Insert the needle(Fig.7)

Please use DPx17 Nm90-120 needle, the thickness of needle should be decided according to the thickness of sewing material & thread. When insert the needle, rotate the hand wheel until the needle bar has reached its top position, loosen the screw on the lower part of the needle bar and insert the needle. Be sure that the long groove of

the needle directed toward the operator and check whether the needle shank has reached the bottom of the needle hole. Fix the needle by tightening the screw.

Warning!

Before insert the needle, be sure to switch off the main switch.

If the terylene thread is broken when backstitch, turn the needle groove to right, maybe can avoid this condition. Normally avoid letting the needle groove face to left.

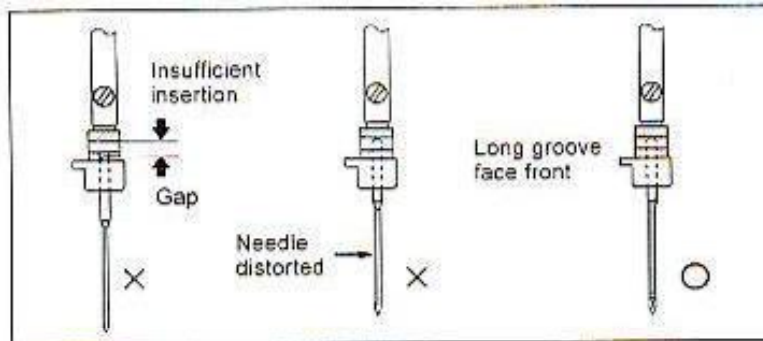

Fig.7

16. Put bobbin in hook assembly

Bring out 5mm lower thread from bobbin. Turn the thread winding direction to right. Insert the bobbin case with the bobbin into the hook. To prevent the bobbin from falling out of the case, while being inserted into the hook, tilt the lock fixing the bobbin in the case. With your thumb, push the bobbin case in until you hear a short distinct sound. The correct position of the bobbin case in the hook signaled by this sound is very important, because otherwise a needle rupture or another breakdown could occur at the following machine start.

17. To thread upper thread(Fig.8)

Let the take up lever at its highest position. Then threading as shown in Fig.8. Unwind a sufficient portion of thread, and pass it through the thread guide (1) and (2), then lead it through the tension disc (6) and thread take up spring (5), thread guides (7), (4) and (3) into the thread take-up lever. Then downwards through the thread guide (4) and the lower thread guide (8) to the thread guide (9) on the needle bar, and to the needle. Insert it into the needle ear from the front side to the rear side.

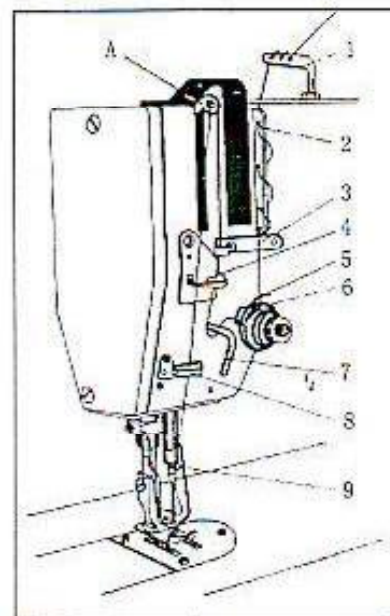

Fig.8

18. To catch lower thread

Hold the end part of upper thread by left hand; turn the pulley wheel slowly by right hand. The upper thread was being took up and lead the lower thread out. Make them coordinative, then pass them through the underside of presser foot, put them behind the position of needle. Put some materials under presser foot before start sewing. The take up level must at its highest position when start and end the sewing.

19. The stitch length and backstitch adjustment (Fig.9, Fig.10)

- 1) The stitch length can be adjusted by turning the knob (4) provided on the column of the machine arm, from 0 to 5mm. By turning it in the sense of the arrow "A", you increase the stitch length. By turning it in the sense of the arrow "B", you decrease it.
- 2) Depress the backstitch hand lever (1) can proceed backstitch.
- 3) Depress the backstitch button as shown in Fig. 10 can proceed backstitch.

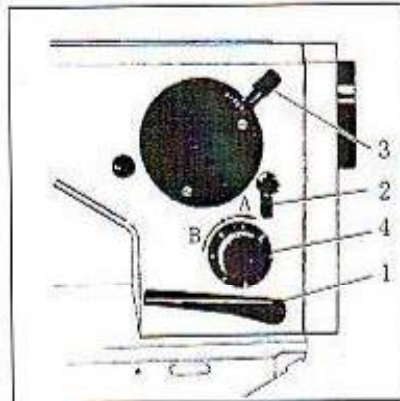

Fig.9

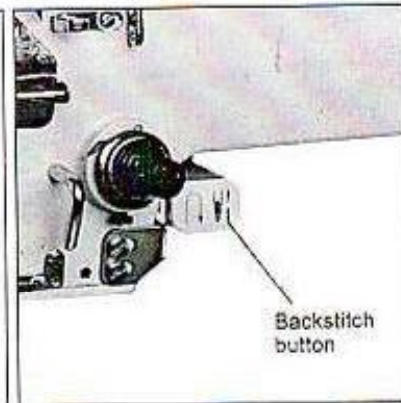

Fig.10

20. The stitch width adjustment (Fig.9)

Before adjustment of the stitch width, the machine must be stopped and the needle outside the sewn work. Release the locking spanner (2) (anticlockwise) and then adjust stitch width through the spanner (3). By displacing the lever to the right can increase the zigzag stitch width. By displacing it to the left can decrease it. Lock the locking spanner (2) after the adjustment is well.

21. The thread tension adjustment (Fig.11,12,14)

The tension of upper and the lower thread must be interrelated that the stitch forming and the sewn material. (Fig.12)

- 1) To adjust the upper thread tension according to the lower thread tension. Turn the tension adjustive nut in clockwise to increase the tension, or inversely, to decrease it.
- 2) To adjust the lower thread tension by turning adjustive screw A in Fig.14.
- 3) It can adjust the take up spring to adjust upper thread tension for special sewn material and thread.

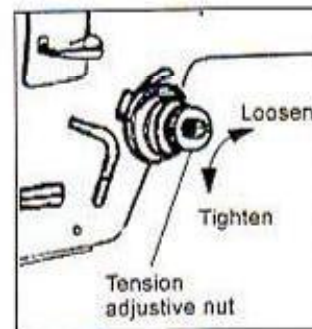

Fig.11

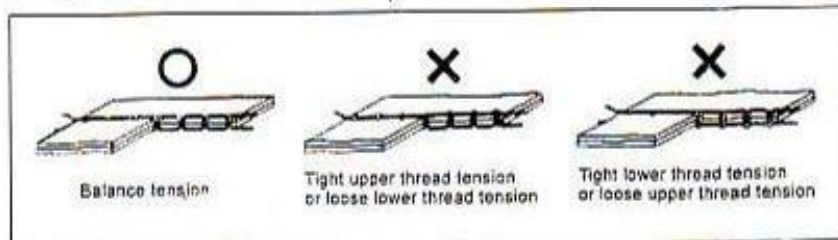

Fig.12

22. The thread take up spring tension adjustment(Fig.13)

Loosen thread tension assembly screw (1), take away the thread tension assembly from machine to adjust take up spring (4). Firstly loosen the screw (2) of bushing (3), and then adjust the angle position of lever (5). Turn it to left can increase the elasticity of spring, or inversely, to decrease it.

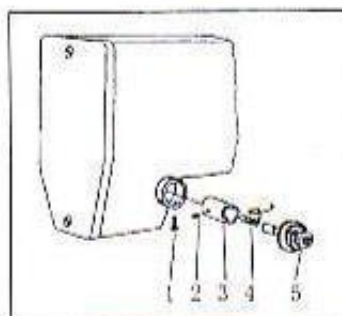

Fig.13

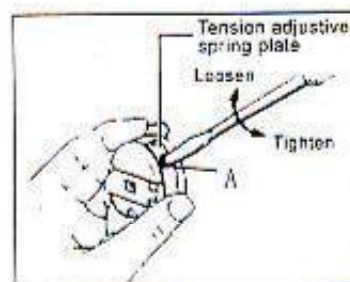

Fig.14

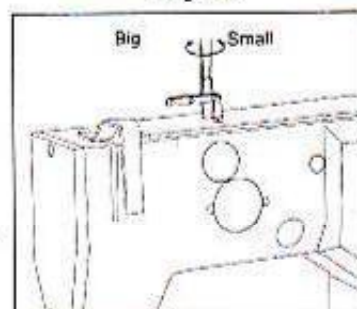

Fig.15

23. The presser foot pressure adjustment (Fig.15)

1) To adjust the presser foot pressure according to the sewn material.

2) Adjustment as shown in Fig.15.

3) The pressure of sewing must be adjusted as its min. value. But at same time, the pressure of pressure foot must be sufficient to ensure reliable and continuous feeding even at the top speed.

24. The gap between hook assembly and needle adjustment(Fig.16)

Adjust the stitch forming width to zero and turning round the hand wheel towards the machine, when the needle goes up 2mm from the lowest position, the position of needle hole should be lower 1.6mm than hook top. The hook top position should be accordant with the centerline of needle and the gap from hook top to needle slot bottom should be 0.05mm.

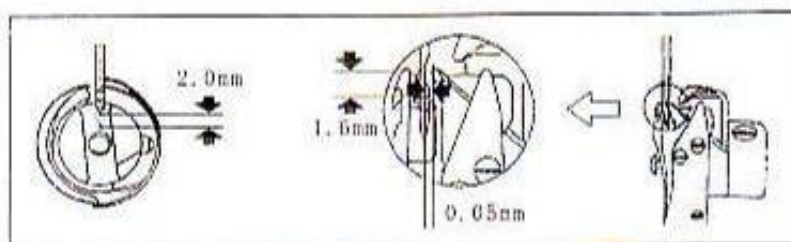

Fig.16

25. The feed dog height adjustment (Fig.17)

The height of feed dog should be higher 1.0mm than needle plate. It is the standard for leaving factory. The height of feed dog can be adjusted to 0.8-1.2mm according to sewn material. To adjust it, turn pulley wheel to the highest position of feed dog, loosen the screw (2) of the lifting lever (8) on the shaft (6), adjust it to the required height of the feed dog and retighten the screw.

26. The feed dog obliquity adjustment(Fig.17)

The standard position of feed dog is horizontal. It can be adjusted according to sewn material. To adjust it, loosen the screw (1) of the feeding lever (9) on the shaft (7), adjust the rear part of feed dog by correspondingly adjusting the position of eccentric pin (5), adjust it to the required height of the feed dog and retighten the screw.

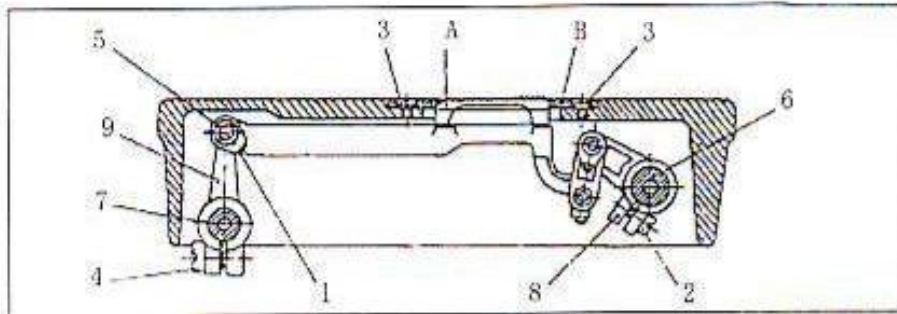

Fig.17

27. The needle punches into the center of the slot of the throat plate position adjustment (fig.5)

Adjust the stitch to the zero width and turn the pulley wheel until the needle reaches its bottom position. At the same time, the needle should be in the center of the needle plate slot both longitudinally and transversely.

1) The needle punches longitudinally into the center of the needle plate slot position adjustment (Fig.18)

Screw out the two screws of the panel, loosen the securing screws (1) and (2), and finely adjust the position of the screw (3) both on the front and on the rear side of the machine arm so as to set the needle longitudinally into the center of the needle plate slot. Retighten the screws (1) and (2) and mount the panel.

To observe: When tightening the adjustable screw for adjusting the needle position, do not tighten them completely but leave a movement space between them in order not to obstruct the transverse movement of the needle bar bracket required for stitch.

2) The needle punches transversely into the center of the needle plate slot position adjustment (Fig.19)

Adjust the stitch to the zero width and turn the pulley wheel until the needle reaches its bottom position. Screw out two screws (2) of stitch width indicating dial (1) and take away the dial (1).

Loosen slide block screw(3), adjust the needle punches position through moving the slide block up and down. Retighten the screws (3) and mount the dial after the adjustment is well.

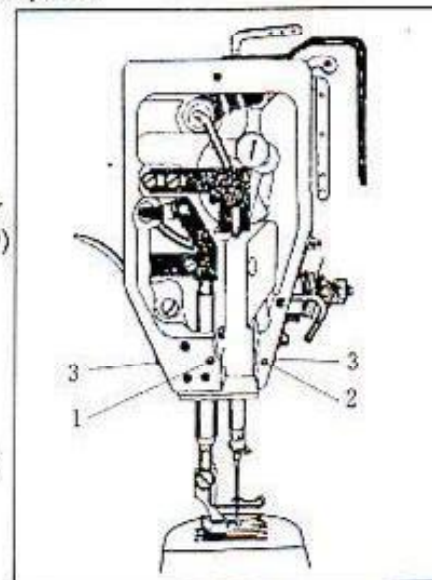

Fig.18

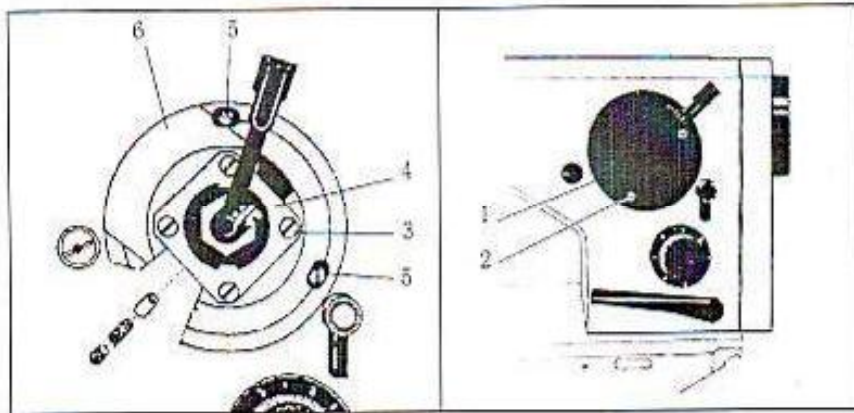

Fig.19

28. The needle base point offset adjustment(Fig.19)

It needs to adjust the needle base point offset if the stitch forming doesn't the straight line when straight sewing. The adjustive method as below:

- 1) Turn the stitch width to zero.
- 2) Screw out two screws (2) of stitch width indicating scale (1) and take away the dial (1), loosen the turntable screw (5).
- 3) To adjust the needle base point offset by turning the turntable (6).
- 4) Retighten the turntable screw and mount the dial after the adjustment is well.

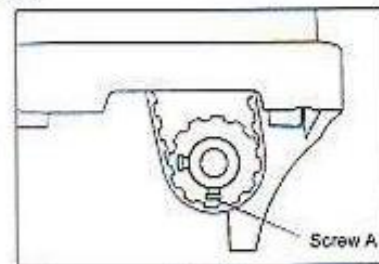

Fig.20

29. Install synchronous belt(Fig.20)

Remount the synchronous belt according to following method:

- 1) Turn pulley wheel to the highest position of feed dog.
- 2) Lean the machine head backward. Turn the synchronous pulley of lower shaft, amount the belt when the first screw A face downwardly

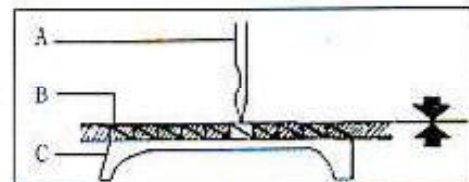

Fig 21

30. Timing between needle and feed dog motion(Fig.21,22)

When needle point A reaches needle plate top surface B, feed dog surface C should be keep accordant on height (Fig.21) with needle plate top surface. It is the standard synchronous relationship. Adjustive method as below:

- 1) Orientation of lifting feed dog cam: Lean the machine head backward, Loosen screw(5), press lifting feed cam (6), turn pulley lightly, retighten the screw (5) when the angle becomes 90° between the orientation mark point of lifting feed cam with the groove of feed cam (7).
- 2) Loosen the synchronous pulley screw of lower shaft, turn the pulley in machine rotation direction till the needlepoint move downward to touch the top surface of needle plate. Then turn lower shaft in machine rotation direction, retighten.



Fig 22

the synchronous pulley screw when feed dog surface keep accordant on height with needle plate top surface.

31. The forward/backward stitch length error adjustment(Fig.22)

- 1) Adjust the forward/backward stitch length error through to adjust the position of the backstitch block on backstitch connection shaft.
- 2) Lean the machine head backward, loosen backstitch block screw (1). At same time, press backstitch pin (3) of backstitch connection shaft (2) in order to avoid it fall off backstitch control lever crank (4).
- 3) Backstitch length will be increased when remove backstitch block to right, and it will be decreased when remove backstitch block to left.
- 4) Retighten backstitch block screw (1) after the adjustment is well.

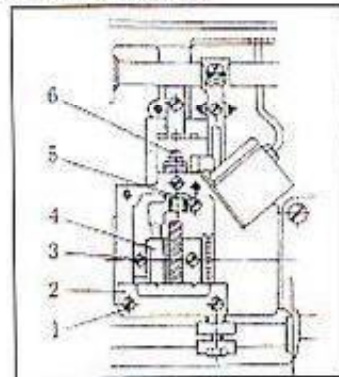

Fig.23

32. The position between hook and opener motion adjustment(Fig.23)

- 1) Lean the machine head backward, screw out the bottom cover screw (1) of hook saddle, open bottom cover (2).
- 2) Put the needle bar to its lowest position.
- 3) Loosen thread finger cam screw (3), adjust thread finger cam (4), make thread finger site on the nearest position of hook, and then retighten thread finger cam screw.
- 4) Loosen hook opener screw (5), adjust the distance between thread finger and hook is 0.3-0.4mm.

33. The thread trimming device adjustment(Fig.24)

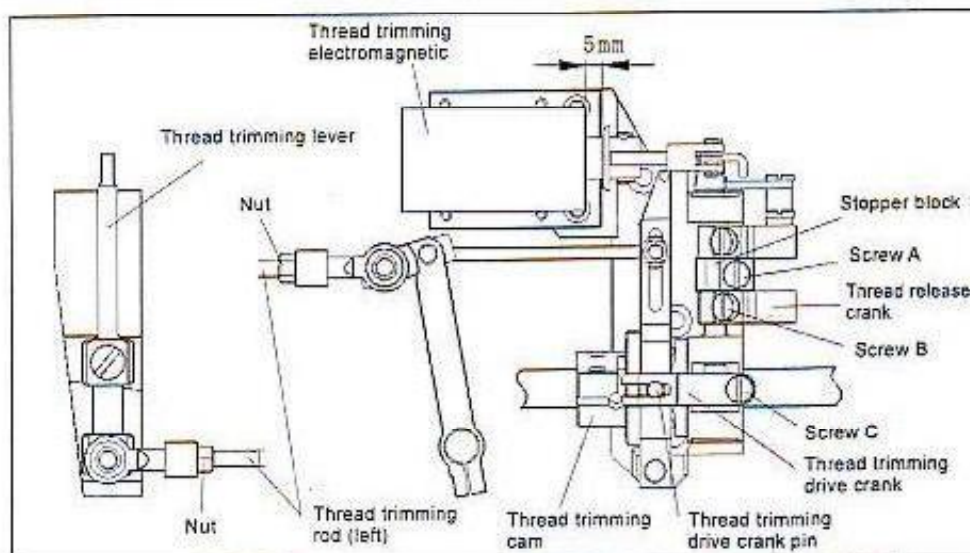

Fig.24

- 1) Adjustment of thread trimming electromagnetic stroke
 - A. The standard stroke is 5.0mm.
 - B. To adjust thread trimming electromagnetic stroke through to adjust the screw A of

stopper block.

2) Adjustment of thread trimming cam

- A. Turn pulley till the needle to its lowest position.
- B. Press the thread trimming drive crank, put the thread trimming drive crank pin into groove of thread trimming cam.
- C. Turn pulley. adjust thread trimming cam till the movable knife start to move and the take up lever start to lift from its lowest position.

3) Adjustment of gap between thread trimming drive crank pin and thread trimming cam (Fig.25)

- A. Turn pulley till the needle to its lowest position.
- B. Loosen screw C of thread trimming drive crank, put the thread trimming drive crank pin into groove of thread trimming cam.
- C. Adjust the distance between the surface of thread trimming drive crank pin with the bottom of thread trimming cam groove is 0.5mm, retighten screw C of Thread trimming drive crank.

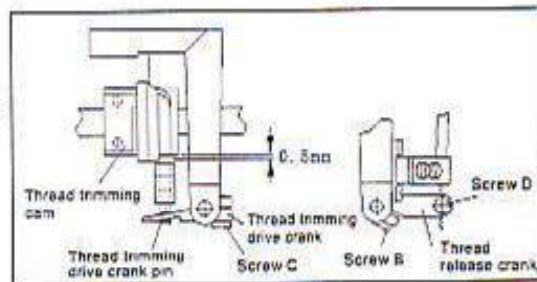

Fig.25

4) Adjustment of movable knife position (Fig.26)

- A. Loosen two nuts of thread trimming rod (left).
- B. To adjust the thread trimming rod (left), make the distance between the acclivitous forepart surface of movable knife with the forepart of fixed knife is 0-0.5mm, then retighten nut.

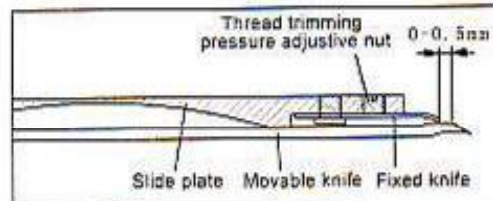

Fig.26

5) Adjustment of pressure of movable knife and fixed knife (Fig.26)

- A. Turn the thread trimming pressure adjustable nut of slide plate to adjust the mesh power of movable knife and fixed knife.
 - B. To confirm the thread trimming whether is sharp by moving the movable knife after ending adjustment.
- To observe: The more mesh power will bring large operation moment and failure trimming, so it should to be adjusted to its minimum.

6) Adjustment of releasing gap of thread tension disc (Fig.25)

- A. Turn pulley till the needle to its lowest position.
- B. Press the thread trimming drive crank, put the thread trimming drive crank pin into groove of thread trimming cam.
- C. Turn pulley till the take up lever to its lowest position. Here the releasing gap of thread tension disc should be its maximal.
- D. The ringent degree can be adjusted through thread release crank and release soft-shaft connection. During adjustment, loosen the screw D of release soft-shaft connection and shrink the flexible wire.

A. Arm bed and its accessories

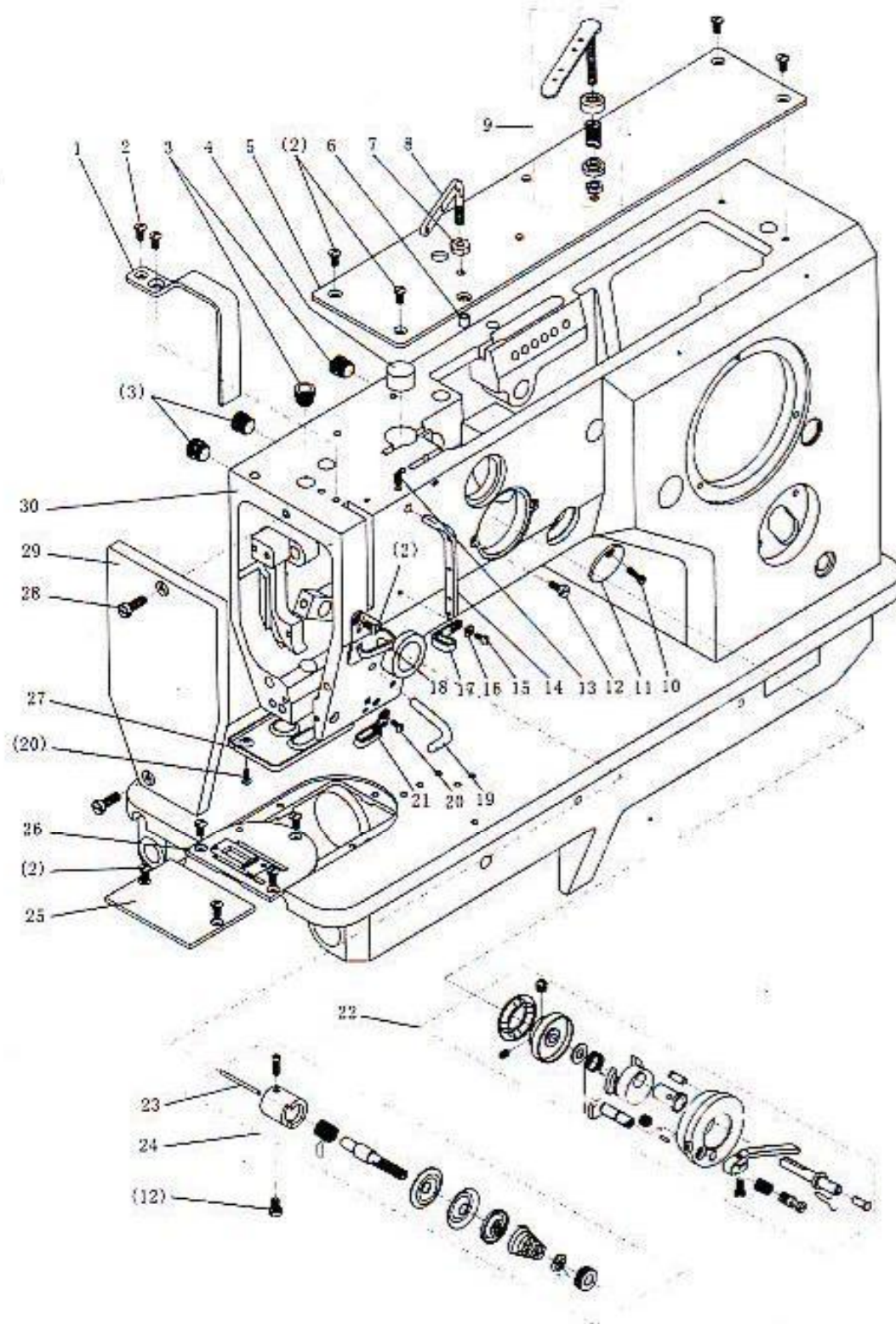

A. Arm bed and its accessories

No.	PartNo.	Name	Qty.		Remark
			82800	82800-D	
A01	7.02.11.059	Thread take up lever guard cover	1	1	
A02	7.02.15.388	Thread take up lever guard cover screw	12	10	M4×8
A03	7.02.16.058	Plastic plug	5	4	
A04		Felt	1	1	
A05	7.02.11.060	Top cover	1	1	
A06	7.02.16.078	Aluminium oil spile	1	3	
A07		Nut	1	3	
A08	7.02.14.031	Thread guide lever(upper)	1	1	
A09	7.02.14.032	Winder thread clip small assy.	1	1	
A10	7.02.15.393	Round cover screw	1	1	M3×12
A11	7.02.11.063	Round cover	1	1	
A12	7.02.15.006	Winder fixed screw	3	3	M4×8
A13	7.02.15.391	Thread guide lever (middle) screw	1	1	M4×5
A14	7.02.14.029	Thread guide lever (middle)	1	1	
A15	7.02.15.392	Thread guide plate screw	1	1	M3×6
A16	7.02.18.070	Screw washer	1	1	GB/T97.1 3
A17	7.02.14.028	Thread guide plate	1	1	
A18	7.02.14.027	Thread guide plate	1	1	
A19	7.02.14.025	Thread guide lever(lower)	1	1	
A20	7.02.15.390	Lower thread guide plate screw	3	3	M3×8
A21	7.02.14.026	Lower thread guide plate	1	1	
A22	7.02.01.044	Winder assy.	1	1	
A23	7.02.10.088	Release pin	1	1	
A24	7.02.01.038	Thread tension assy.	1	1	
A25	7.02.02.085	Slide plate	1		
A26	7.02.02.086	Needle plate	1	1	
A27	7.02.11.062	Felt splint	1	1	
A28	7.02.15.389	Panel screw	2	2	M5×14
A29	7.02.11.061	Panel	1	1	
A30	7.01.02.013	Machine frame	1	1	

B. Arm shaft and needle bar thread take up parts

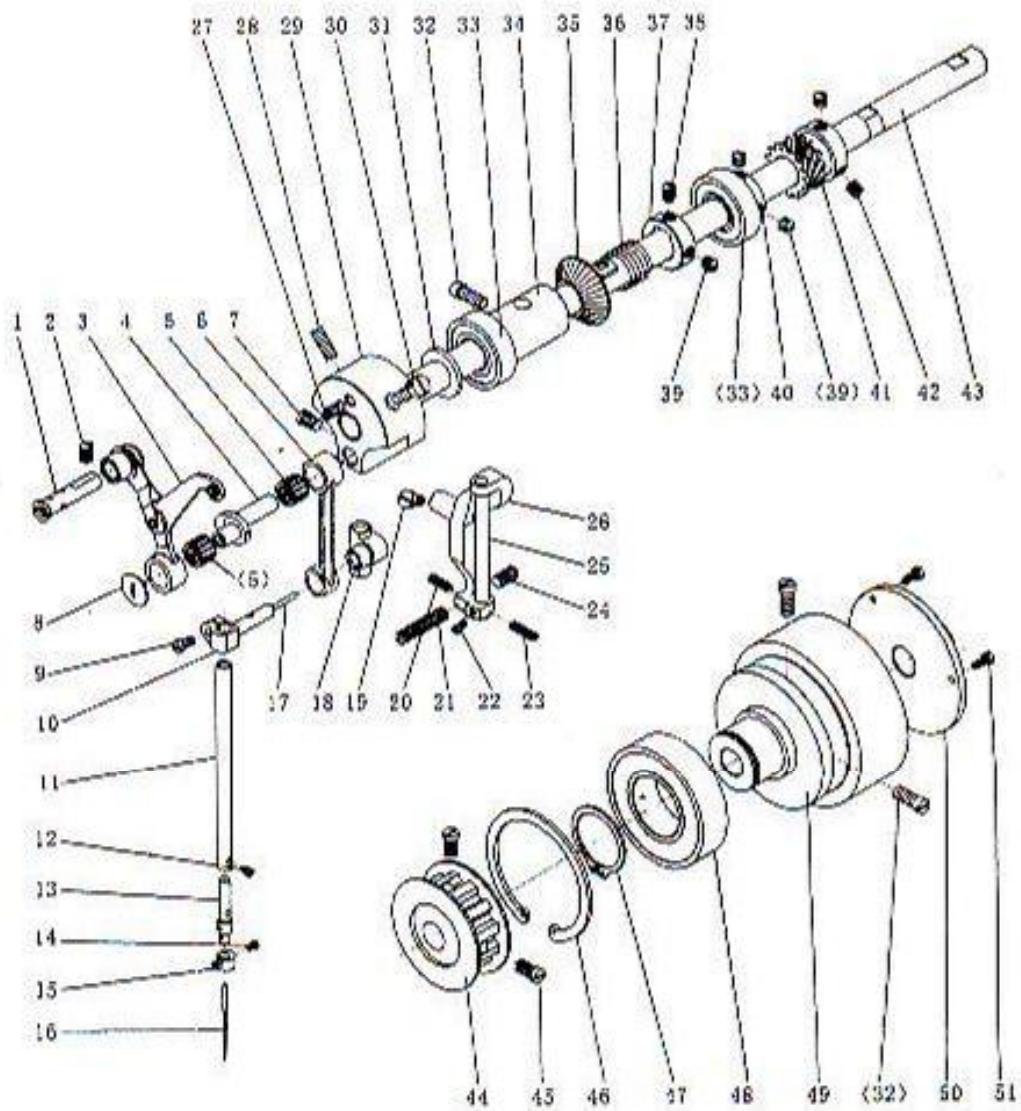

B. Arm shaft and needle bar thread take up parts

No.	PartNo.	Name	Qty.		Remark
			82800	82800-D	
B01	7.02.10.091	Thread take up lever support stud	1	1	
B02	7.02.15.411	Thread take up lever support stud screw	1	1	M6(0.75)×8
B03	7.02.05.066	Thread take up lever assy.	1	1	
B04	7.02.06.036	Libra crank	1	1	
B05	7.02.04.025	Bearing	2	2	HK0810
B06	7.02.05.067	Needle bar link rod	1	1	
B07	7.02.15.395	Libra crank screw	1	1	M6(0.75)×7.5
B08	7.02.15.413	Thread take up crank screw	1	1	9/64(40)×5.5(left)
B09	7.02.15.408	Needle bar joint screw	1	1	M4×8
B10	7.02.02.088	Needle bar joint	1	1	
B11	7.02.03.071	Needle bar	1	1	
B12	7.02.15.409	Needle clamp shaft screw	1	1	M2.5×5
B13	7.02.10.090	Needle clamp shaft	1	1	
B14	7.02.15.412	Screw	1	1	M3×5.8
B15	7.02.14.030	Needle clamp washer	1	1	
B16	7.02.21.140	Needle	1	1	19"
B17		Needle bar joint oil wick	1	1	∅2×25mm
B18	7.02.05.065	Needle bar connection holder	1	1	
B19	7.02.15.056	Needle bar connection bracket tighten screw	1	1	M5×5
B20	7.02.15.400	Needle bar connection bracket screw (back)	1	1	M4×12
B21	7.02.15.401	Needle bar connection bracket screw (left)	1	1	M6(0.75)×30
B22	7.02.15.037	Needle bar connection bracket shaft screw	1	1	M3×6
B23	7.02.15.404	Needle bar connection bracket screw (front)	1	1	M4×16
B24	7.02.15.403	Needle bar connection bracket screw (right)	1	1	M6(0.75)×11
B25	7.02.10.089	Needle bar connection bracket shaft	1	1	
B26	7.02.05.064	Needle bar connection bracket	1	1	
B27	7.02.15.396	Tighten screw	1	1	M5×10
B28	7.02.15.397	Needle bar crank tighten screw	1	1	M6(0.75)×15
B29	7.02.16.035	Needle bar crank	1	1	
B30	7.02.15.398	Needle bar crank orientation screw	1	1	M6(0.75)×17.5
B31		Felt	1	1	
B32	7.02.15.399	Arm shaft bushing screw	1	1	M6×14
B33	7.02.04.024	Arm shaft bearing	2	2	6003
B34	7.02.08.095	Arm shaft bushing	1	1	
B35	7.02.07.059	Winder drive pulley	1	1	
B36	7.02.17.094	Replacement spring	1	1	
B37	7.02.09.032	Winder drive pulley collar	1	1	

B. Arm shaft and needle bar thread take up parts

No.	PartNo.	Name	Qty.		Remark
			82800	82800-D	
B38	7.02.15.407	Drive pulley orientation screw	1	1	M6(0.75)×7
B39	7.02.15.428	Collar screw	3	3	M6(0.75)×5
B40	7.02.08.102	Arm shaft bearing collar	1	1	
B41	7.02.07.051	Vibrating needle drive gear	1	1	
B42	7.02.15.126	Small gear screw	3	3	1/4(40)×7
B43	7.02.03.070	Arm shaft	1	1	
B44	7.02.07.053	Synchronous pulley (upper)	1	1	
B45	7.02.15.431	Synchronous pulley screw	2	2	M6(0.75)×10
B46	7.02.18.076	Elasticity stop ring	1	1	GB/T893.1-1986-62
B47	7.02.18.078	Elasticity stop ring	1	1	GB/T894.1-1986-30
B48	7.02.04.027	Arm shaft bearing(right)	1	1	6206
B49	7.02.07.054	Pulley	1	1	
B50	7.02.11.064	Pulley cover	1	1	
B51	7.02.15.432	Pulley cover screw	3	3	M3×8

C. Needle bar vibrating parts

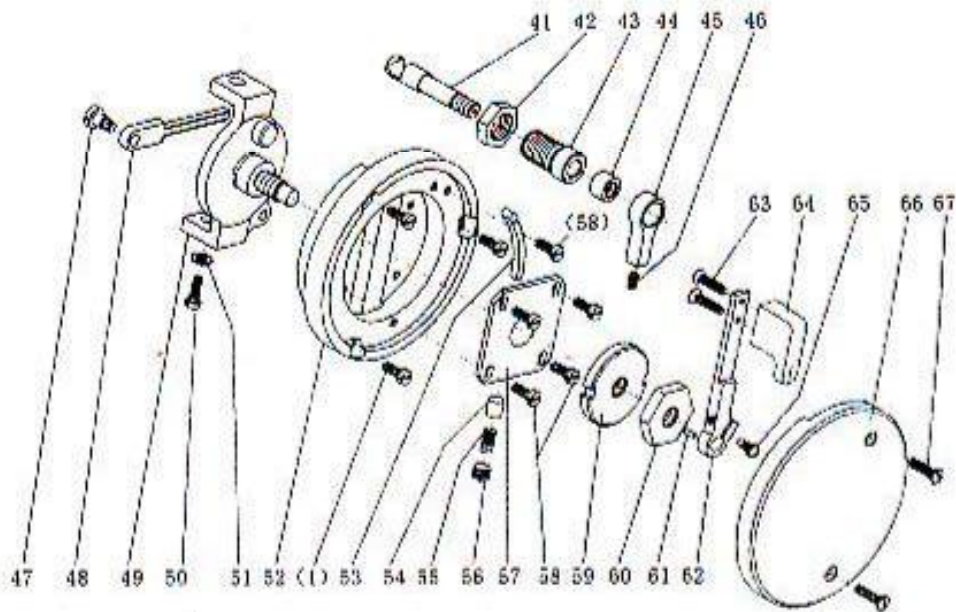
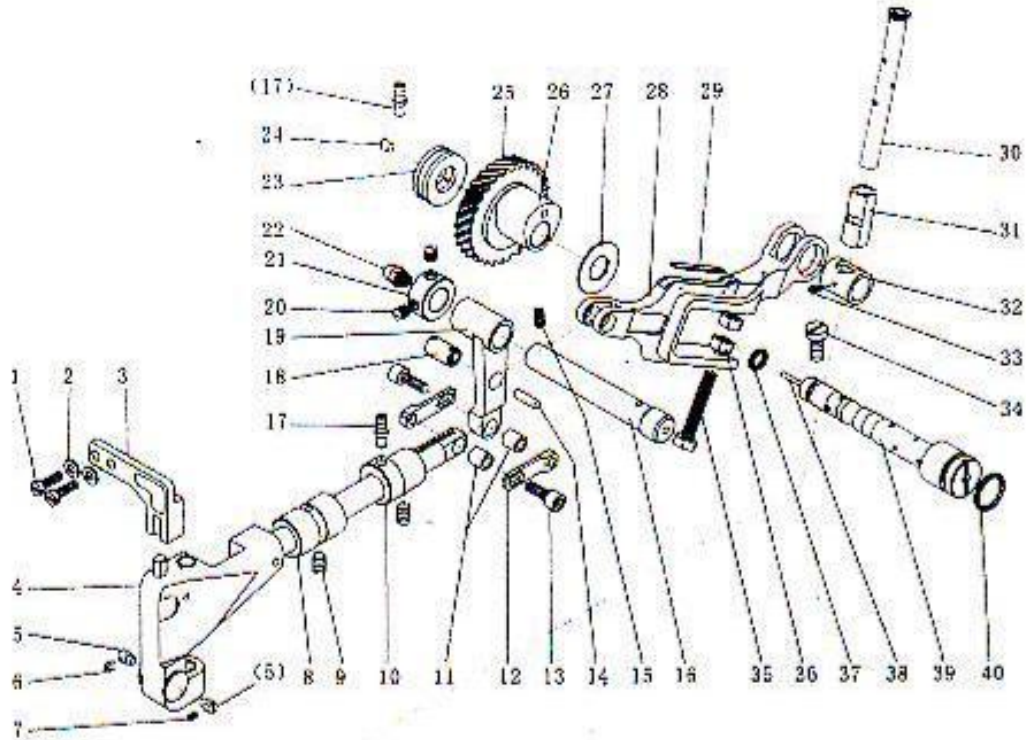

C. Needle bar vibrating parts

No.	PartNo.	Name	Qty.		Remark
			82800	82800-D	
C01	7.02.15.405	Fixed bracket screw	5	5	M4×14
C02	7.02.18.071	Washer	2	2	GB/T97.1 4
C03	7.02.13.043	Needle bar vibrating fixed bracket	1	1	
C04	7.02.01.039	Needle bar vibrating bracket	1	1	
C05	7.02.15.407	Needle bar vibrating bracket screw	2	2	M6(0.75)×7
C06	7.02.15.391	Tighten screw	1	1	M4×5
C07	7.02.15.406	Tighten screw	1	1	M3×4
C08	7.02.08.096	Needle bar vibrating shaft bushing (left)	1	1	
C09	7.02.15.410	Needle bar vibrating shaft bushing screw	2	2	M6×8
C10	7.02.08.097	Needle bar vibrating shaft bushing (right)	1	1	
C11	7.02.08.101	Connection bushing	2	2	
C12	7.02.17.091	Connection plate	2	2	
C13	7.02.15.443	Connection screw	2	2	M5(0.5)×14
C14		Felt	1	1	
C15	7.02.15.049	Needle feeding crank shaft tighten screw	1	1	M5×8
C16	7.02.03.075	Needle feeding crank shaft	1	1	
C17	7.02.16.059	Oil spile	2	2	
C18	7.02.10.093	Connection shaft	1	1	
C19	7.02.05.076	Link lever	1	1	
C20	7.02.15.428	Collar screw	2	2	M6(0.75)×5
C21	7.02.09.030	Needle feeding crank shaft collar	1	1	
C22	7.02.16.067	Coppery oil spile	1	1	
C23	7.02.04.026	Bearing	1	1	51101
C24	7.02.16.064	Aluminium oil plug	1	1	
C25	7.02.07.050	Vibrating needle driven gear	1	1	
C26	7.02.06.037	Vibrating needle cam	1	1	
C27	7.02.18.075	Coppery washer	1	1	
C28	7.02.05.077	Vibrating needle link lever	1	1	
C29		Felt	1	1	
C30	7.02.03.074	Vibrating range shaft	1	1	
C31	7.02.08.099	Vibrating bushing	1	1	
C32	7.02.08.100	Connection bushing	1	1	
C33	7.02.15.427	Connection bushing screw	1	1	M2×4
C34	7.02.15.426	Vibrating needle eccentric shaft screw	1	1	M6×12
C35	7.02.15.446	Vibrating needle link rod screw	1	1	M6(0.75)×34
C36	7.02.15.449	Vibrating needle link rod screw locking nut	2	2	M6(0.75)
C37	7.02.16.056	Vibrating needle eccentric shaft o-ring (small)	1	1	

C. Needle bar vibrating parts

No.	PartNo.	Name	Qty.		Remark
			82800	82800-D	
C38		Oil wick	1	1	Φ2×80mm
C39	7.02.10.094	Vibrating needle eccentric shaft	1	1	
C40	7.02.16.066	O-ring (big)	1	1	
C41	7.02.01.04102	Vibrating needle bracket connector	1	1	
C42	7.02.01.04103	Vibrating needle bracket nut	1	1	
C43	7.02.01.04104	Vibrating needle bracket holder	1	1	
C44	7.02.01.04105	Nut	1	1	
C45	7.02.01.04106	Vibrating needle locking spanner	1	1	
C46	7.02.01.04107	Vibrating needle locking spanner screw	1	1	
C47	7.02.15.425	Vibrating needle bracket link rod screw	1	1	
C48	7.02.01.04101	vibrating needle bracket link rod	1	1	
C49	7.02.13.044	Vibrating bracket	1	1	
C50	7.02.15.416	Vibrating range shaft screw	1	1	M5×12
C51	7.02.18.016	Vibrating range shaft screw washer	1	1	GB/T97.1 5
C52	7.02.13.045	Turntable	1	1	
C53	7.02.17.089	Vibrating needle spanner stop block	1	1	
C54	7.02.16.063	Plug	1	1	
C55	7.02.17.090	Plug spring	1	1	
C56	7.02.15.423	Plug spring screw	1	1	M8(0.75)×5
C57	7.02.12.046	Slide block	1	1	
C58	7.02.15.424	Slide block screw	5	5	M4×12
C59	7.02.15.451	Round nut	1	1	
C60	7.02.15.450	Hexagonal nut	1	1	
C61		Vibrating needle spanner orientation pin	1	1	
C62	7.02.05.071	Vibrating needle spanner	1	1	
C63	7.02.15.421	Vibrating needle spanner handel screw	2	2	
C64	7.02.05.070	Vibrating needle spanner handle	1	1	
C65	7.02.15.417	Vibrating needle spanner screw	1	1	M4×12
C66	7.02.16.062	Scale	1	1	
C67	7.02.15.422	Scale screw	2	2	M4×18

D. Presser foot parts

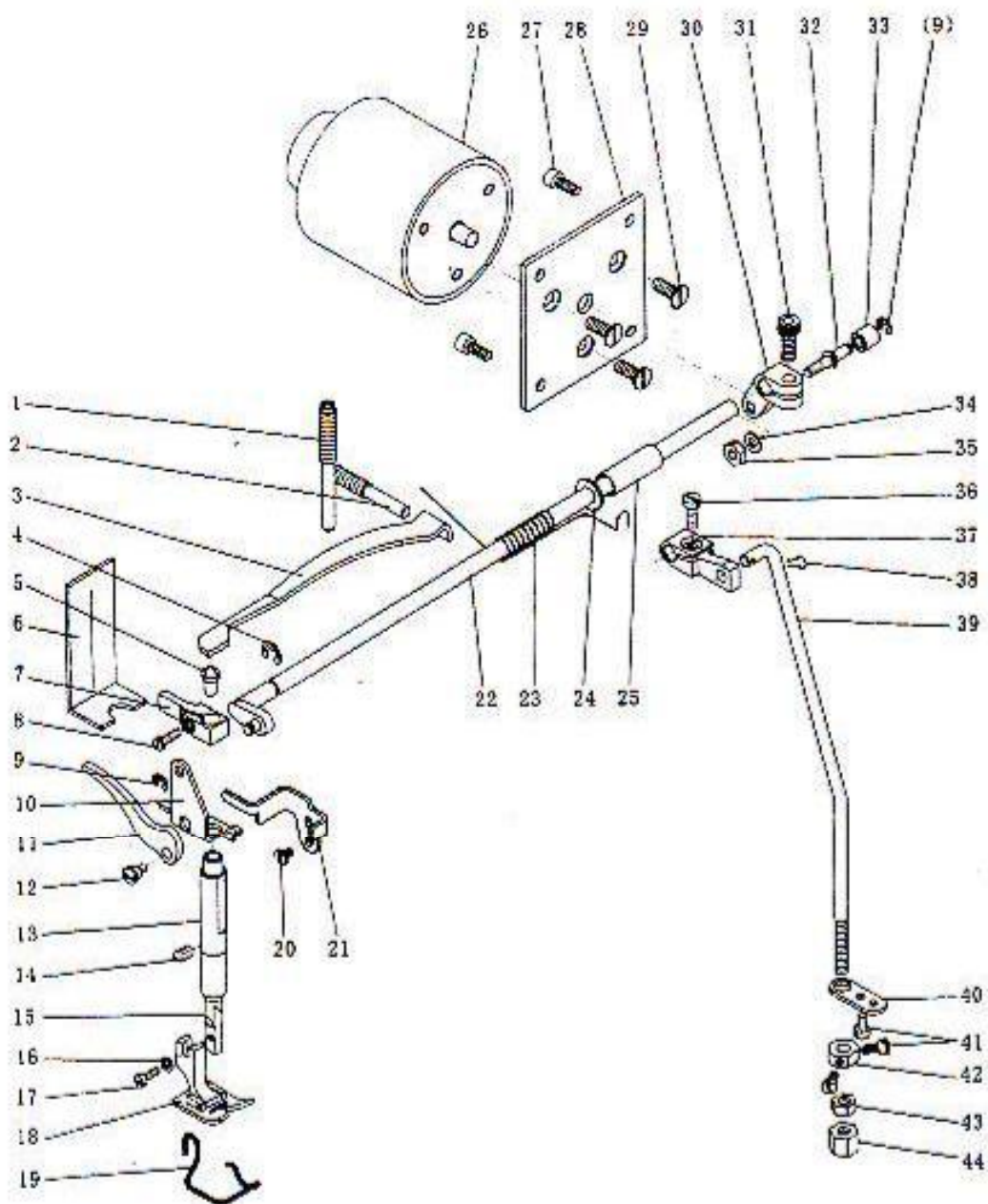

D、Presser foot parts

No.	PartNo.	Name	Qty.		Remark
			82800	82800-D	
D01	7.02.15.414	Presser foot pressure adjustive screw	1	1	
D02	7.02.15.415	Presser bar spring support screw	1	1	
D03	7.02.17.085	Presser bar spring	1	1	
D04	7.02.18.072	E-ring	1	1	GB/T896-1986-6
D05	7.02.10.092	Presser bar pin	1	1	
D06		Felt	1	1	
D07	7.02.12.045	Presser bar slide block	1	1	
D08	7.02.15.417	Presser bar slide block screw	1	1	M4×12
D09	7.02.18.031	E-ring	1	2	GB/T896-1986-4
D10	7.02.17.087	Presser foot lifting connection plate	1	1	
D11	7.02.05.068	Presser bar spanner	1	1	
D12	7.02.15.418	Presser bar spanner screw	1	1	
D13	7.02.08.098	Presser bar bushing	1	1	
D14	7.02.15.411	Presser bar bushing tighten screw	1	1	M6(0.75)×8
D15	7.02.03.072	Presser bar	1	1	
D16	7.02.18.057	Presser foot screw washer	1	1	
D17	7.02.15.419	Presser foot screw	1	1	M3.5×10
D18	7.02.02.089	Presser foot	1	1	
D19	7.02.17.088	Spring	1	1	
D20	7.02.15.394	Release lever screw	1	1	
D21	7.02.05.063	Release lever	1	1	
D22	7.02.03.073	Presser foot lifting shaft	1	1	
D23	7.02.17.086	Replacement spring	1	1	
D24	7.02.18.060	Washer		1	GB/T97.1 8
D25	7.02.08.040	Presser foot lifting shaft bushing		1	
D26	7.02.19.035	presser foot Lifting electromagnetic		1	
D27	7.02.15.053	Fixed plate screw		4	M5×12
D28	7.02.11.095	Lifting presser foot electromagnetic fixed plate		1	
D29	7.02.15.105	Lifting presser foot electromagnetic screw		3	M6×8
D30	7.02.06.081	Presser foot lifting crank		1	
D31	7.02.15.048	Presser foot lifting crank screw		1	M6×15
D32	7.02.10.146	Presser foot lifting crank pin		1	
D33	7.02.12.081	Slide pole		1	
D34	7.02.18.016	Washer		1	GB/T97.1 5
D35	7.02.15.068	Presser foot lifting crank pin nut		1	GB/T 6170 M5
D36	7.02.15.416	Knee lifting crank screw	1		M5×12
D37	7.02.05.069	Knee lifting crank	1		

D、Presser foot parts

No.	PartNo.	Name	Qty.		Remark
			82800	82800-D	
D38	7.02.17.041	Pin	1		
D39	7.02.01.04001	Presser foot lifting link lever	1		
D40	7.02.01.04002	Link lever fixed plate	3		M4×6
D41	7.02.15.420	Link lever fixed plate screw	1		
D42	7.02.01.04003	Link lever collar	1		
D43	7.02.01.04004	Nut	1		
D44	7.02.01.04005	Knee lifting connection nut	1		

E. Stitch length adjustment and backstitch parts

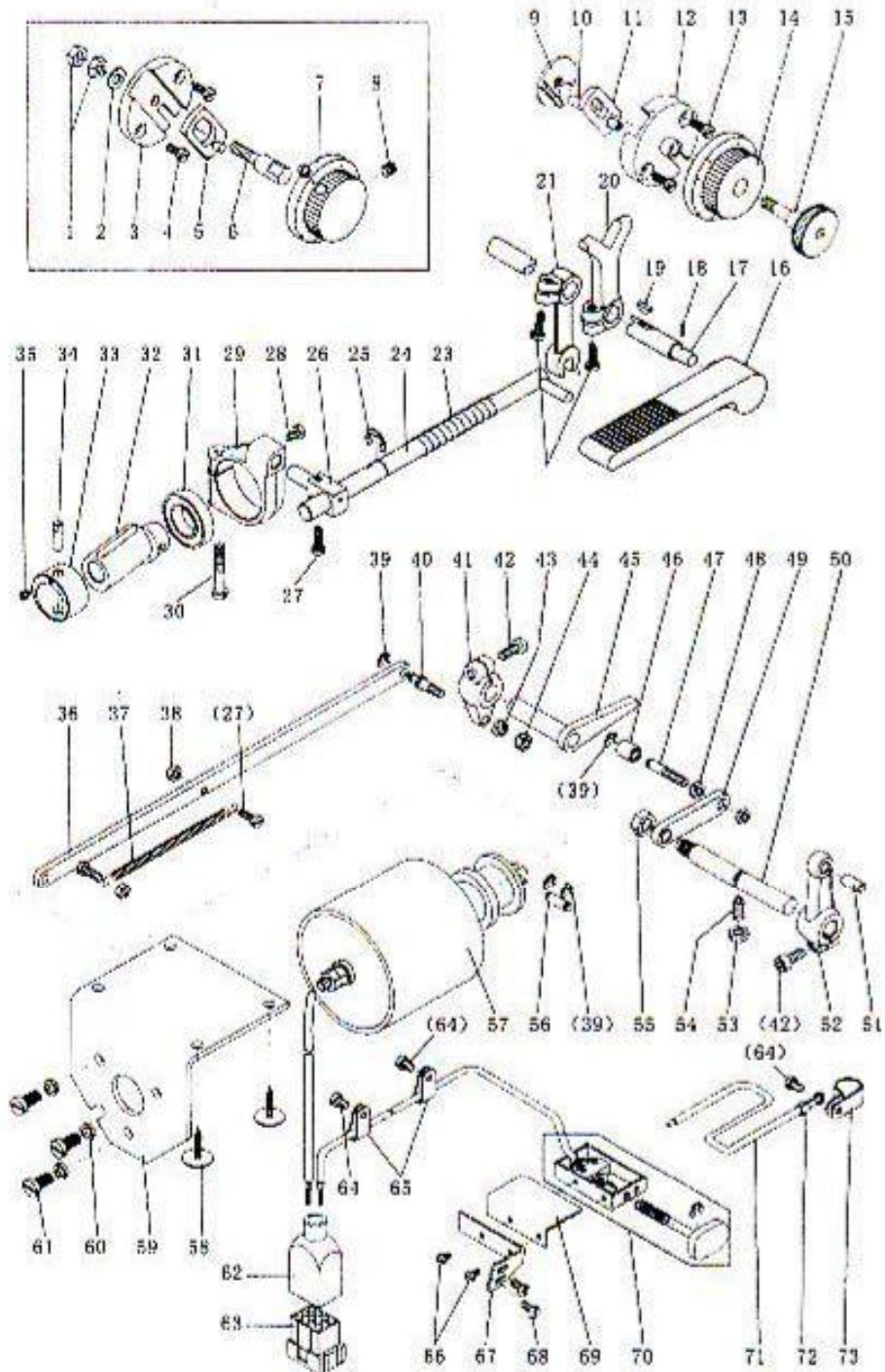

E. Stitch length adjustment and backstitch parts

No.	PartNo.	Name	Qty.		Remark
			82800	82800-D	
E01	7.02.12.047.01	Stitch length indication holder nut	2		
E02	7.02.12.047.02	Washer	1		
E03	7.02.12.047.03	Stitch length indication holder	1		
E04	7.02.15.006	Stitch length indication holder screw	2		M4×8
E05	7.02.12.048	Stitch length adjustive block	1		
E06	7.02.12.047.04	Stitch length indication holder shaft	1		
E07	7.02.16.068	Stitch length indication dial	1		
E08	7.02.15.428	Stitch length indication dial screw	2		M6(0.75)×5
E09	7.02.12.135	Stitch length adjustive tighten block		1	
E10	7.02.05.217	Stitch length adjustive lever		1	
E11	7.02.13.185	Stitch length adjustive block		1	
E12	7.02.13.186	Stitch length indication holder		1	
E13	7.02.15.017	Stitch length indication holder screw		2	M4×10
E14	7.02.16.212	Stitch length indication dial		1	
E15	7.02.05.216	Stitch length dial locking screw		1	
E16	7.02.05.079	Backstitch control lever spanner	1	1	
E17	7.02.03.077	Backstitch control lever	1	1	
E18		Pin	1	1	
E19	7.02.12.049	Backstitch stop lever block	1	1	
E20	7.02.05.078	Stitch length adjustive crank	1	1	
E21	7.02.05.080	Backstitch control lever crank	1	1	
E22	7.02.15.416	Backstitch control lever crank screw	2	2	M5×12
E23	7.02.17.092	Replacement spring	1	1	
E24	7.02.03.076	Backstitch connection shaft	1	1	
E25	7.02.18.021	E-ring	1	1	GB/T896-1986-7
E26	7.02.12.050	Backstitch block	1	1	
E27	7.02.15.424	Backstitch block screw	1	3	M4×12
E28	7.02.15.447	Backstitch block tighten screw	1	1	M4×6
E29	7.02.06.039	Backstitch cam crank	1	1	
E30	7.02.15.436	Backstitch cam crank screw	1	1	M5×30
E31	7.02.04.024	Backstitch cam crank bearing	1	1	6003
E32	7.02.01.04201	Feed backstitch cam	1	1	
E33	7.02.01.04202	Feed backstitch cam bushing	1	1	
E34	7.02.01.04203	Orientation pin	1	1	
E35	7.02.01.04204	Orientation pin screw	1	1	
E36	7.02.05.175	Backstitch link lever		1	
E37	7.02.17.033	Backstitch link lever replacement spring		1	

E. Stitch length adjustment and backstitch parts

No.	PartNo.	Name	Qty.		Remark
			82800	82800-D	
E38	7.02.15.268	Replacement spring nut	2		GB/T 6170 M4
E39	7.02.18.031	E-ring	4		GB/T896-1986-4
E40	7.02.10.149	Backstitch link lever crank pin	1		
E41	7.02.06.083	Backstitch link lever crank	1		
E42	7.02.15.053	Backstitch link lever crank screw	2		M5×12
E43	7.02.18.055	Spring washer	1		GB/T93. 5
E44	7.02.15.068	Backstitch link lever crank pin nut	1		GB/T6170 M5
E45	7.02.21.176	Knee lifting Lever assy.	1		
E46	7.02.07.071	Foot control shaft link lever screw roller	1		
E47	7.02.15.107	Foot control shaft link lever screw	1		
E48	7.02.15.108	Foot control shaft link lever nut	2		GB/T6172 M5
E49	7.02.05.176	Foot control shaft link lever	1		
E50	7.02.03.112	Foot control backstitch shaft	1		
E51	7.02.10.148	Foot control backstitch crank pin	1		
E52	7.02.21.173	Foot control backstitch crank	1		
E53	7.02.15.089	Stop screw/nut	1		GB/T6172 M6
E54	7.02.15.088	Stop screw	1		M6×12
E55	7.02.15.106	Foot control shaft nut	1		M8 (左)
E56	7.02.10.147	Backstitch electromagnetic pin	1		
E57	7.02.19.036	Backstitch electromagnetic	1		
E58	7.02.21.033	Backstitch electromagnetic fixed plate screw	4		GB/T99 4.5×20
E59	7.02.11.104	Backstitch electromagnetic fixed plate	1		
E60	7.02.18.058	Spring washer	3		GB/T93. 6
E61	7.02.15.007	Backstitch electromagnetic screw	3		M6×10
E62	7.02.19.030	Jacket	1		
E63	7.02.19.027	Socket	1		
E64	7.02.15.420	Wire clip screw	3		M4×6
E65	7.02.16.166	Nylon clip AB-3N	2		
E66	7.02.15.101	Switch box fixed bracket screw	2		M3×4
E67	7.02.13.072	Switch box fixed bracket	1		
E68	7.02.15.005	Switch box screw	2		M4×8
E69	7.02.11.079	Switch box cover plate	1		
E70	7.02.01.059	Backstitch switch assy.	1		
E71	7.02.19.113	Earthing wire	1		
E72	7.02.19.104	Earthing plug	1		
E73	7.02.16.167	Nylon clip AB-8N	1		

F. Lower shaft, feed dog parts

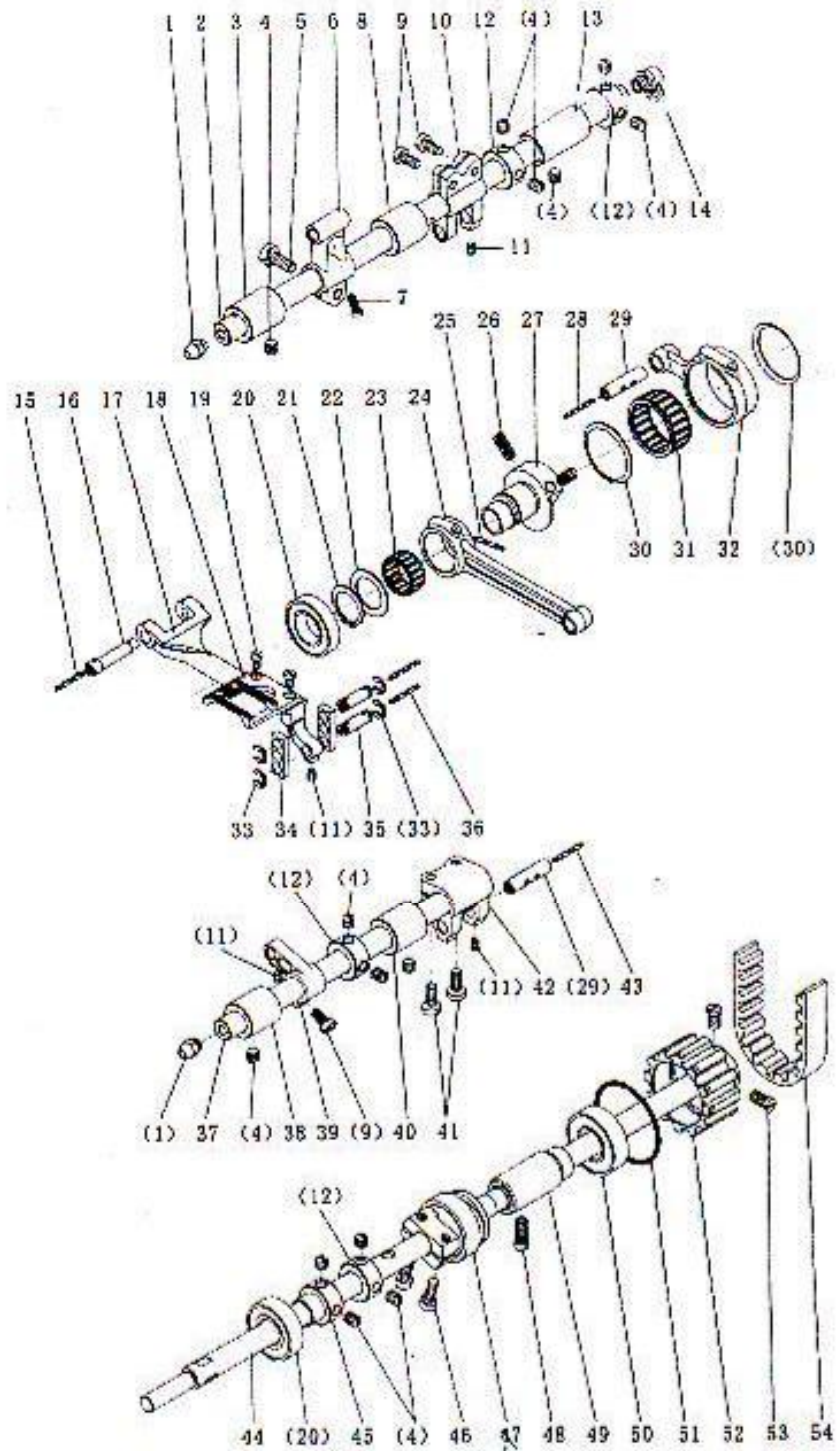

F. Lower shaft, feed dog parts

No.	PartNo.	Name	Qty.		Remark
			82800	82800-D	
F01	7.02.16.067	Oil spile	2	2	
F02	7.02.03.079	Feed shaft	1	1	
F03	7.02.08.103	Feed shaft bushing (left)	1	1	
F04	7.02.15.428	Bushing screw	12	14	M6(0.75)×5
F05	7.02.15.448	Feed crank (left) screw	1	1	M6×14
F06	7.02.05.081	Feed crank (left)	1	1	
F07	7.02.15.408	Feed dog holder adjustive pin screw	1	1	M4×8
F08	7.02.08.104	Feed shaft bushing (middle)	1	1	
F09	7.02.15.430	Feed crank (right) screw	3	3	M5×10
F10	7.02.06.038	Feed crank (right)	1	1	
F11	7.02.15.391	Feed crank pin screw	4	4	M4×5
F12	7.02.09.030	Collar	3	4	
F13	7.02.08.105	Feed shaft bushing (right)	1	1	
F14	7.02.16.072	Oil spile (big)	1	1	
F15		Feed dog holder adjustive pin oil wick	2	2	Φ2×160mm
F16	7.02.10.097	Feed dog holder adjustive pin	1	1	
F17	7.02.02.090	Feed dog holder	1	1	
F18	7.02.02.087	Feed dog	1	1	
F19	7.02.15.433	Feed dog screw	2	2	M4×6
F20	7.02.04.028	Lifting feed dog cam bearing	2	2	6002
F21	7.02.18.079	Elasticity stop ring	1	1	GB/T894.1-1986-18
F22	7.02.18.080	Washer	1	1	
F23	7.02.04.030	Lifting feed dog cam link lever bearing	1	1	
F24	7.02.05.082	Lifting feed dog cam link lever	1	1	
F25		Lifting feed dog cam link lever oil wick	1	1	Φ2×350mm
F26	7.02.15.050	Lifting feed dog cam screw	2	2	M6(0.75)×8
F27	7.02.07.055	Lifting feed dog cam	1	1	
F28		Backstitch cam link lever oil wick	1	1	Φ2×200mm
F29	7.02.10.096	Feed crank pin	2	2	
F30	7.02.18.082	Gear washer	2	2	
F31	7.02.04.029	Backstitch cam link lever bearing	1	1	
F32	7.02.05.083	Backstitch cam link lever	1	1	
F33	7.02.18.031	E-ring	4	4	GB/T896-1986-4
F34	7.02.11.065	Connection plate	2	2	
F35	7.02.10.095	Lifting feed dog link lever pin	2	2	
F36		Lifting feed dog link lever pin oil wick	1	1	Φ2×60mm
F37	7.02.03.080	Lifting feed dog shaft	1	1	

F、 Lower shaft, feed dog parts

No.	PartNo.	Name	Qty.		Remark
			82800	82800-D	
F38	7.02.08.108	Lifting feed dog shaft bushing (left)	1	1	
F39	7.02.05.084	Lifting feed dog crank (left)	1	1	
F40	7.02.18.109	Lifting feed dog shaft bushing (right)	1	1	
F41	7.02.15.389	Lifting feed dog crank (right) screw	2	2	M5×14
F42	7.02.06.040	Lifting feed dog crank (right)	1	1	
F43		Lifting feed dog crank pin oil wick	1	1	Φ2×30mm
F44	7.02.03.078	Lower shaft	1	1	
F45	7.02.08.107	Lower shaft bearing bushing	1	1	
F46	7.02.15.058	Thread trimming cam screw		2	M5×16
F47	7.02.06.080	Thread trimming cam		1	
F48	7.02.15.437	Lower shaft bearing bushing screw	1	1	M6(0.75)×14
F49	7.02.08.106	Lower shaft bearing bushing	1	1	
F50	7.02.04.024	Lower shaft bearing	1	1	6003
F51	7.02.18.081	Synchronous pulley (lower) washer	1	1	
F52	7.02.07.056	Synchronous pulley (lower)	1	1	
F53	7.02.15.431	Synchronous pulley screw	2	2	M6(0.75)×10
F54	7.02.07.052	Synchronous belt	1	1	

G、 Hook assembly

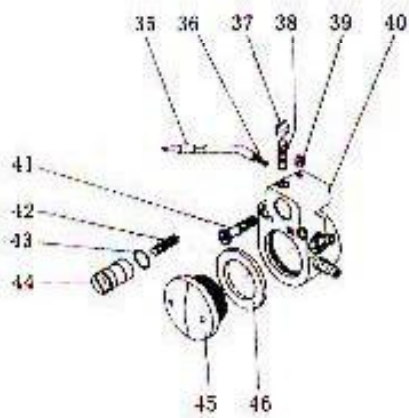
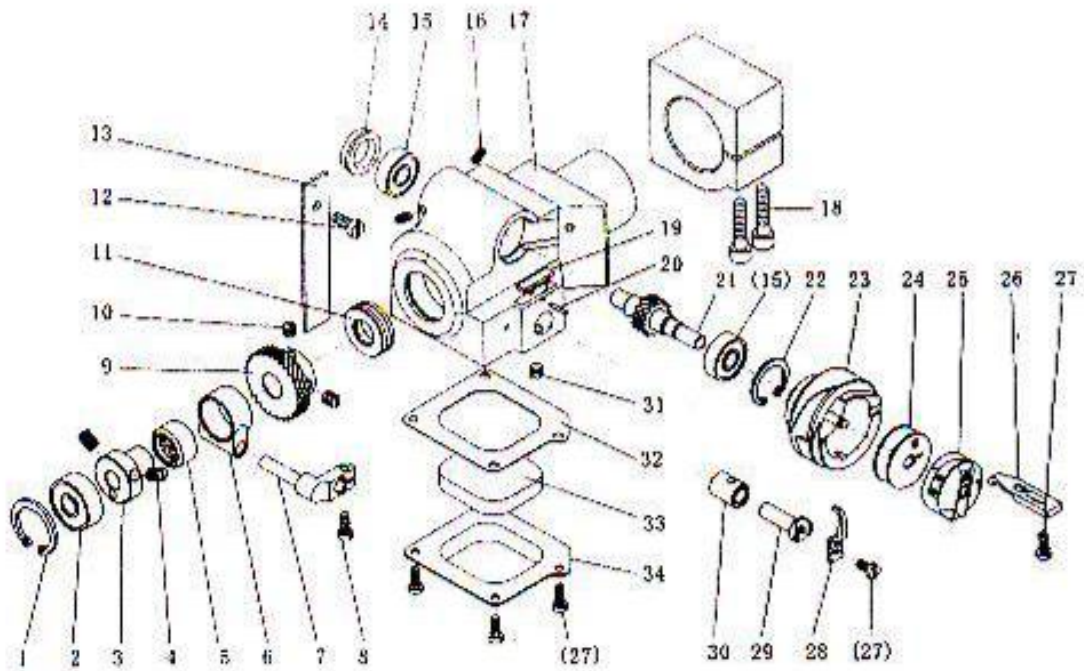

G. Hook assembly

No.	PartNo.	Name	Qty.		Remark
			82800	82800-D	
G01	7.02.18.083	Elasticity stop ring	1	1	GB/T893.1-1986- 26
G02	7.02.04.031	Bearing	1	1	6292
G03	7.02.06.041	Opener cam	1	1	
G04	7.02.15.434	Opener cam screw	2	2	M6(0.75)×7
G05	7.02.04.033	Opener cam bearing	1	1	HK1412
G06	7.02.08.112	Opener cam bushing	1	1	
G07	7.02.08.111	Hook opener	1	1	
G08	7.02.15.017	Hook opener screw	1	1	M4×10
G09	7.02.07.058	Hook drive gear	1	1	
G10	7.02.15.126	Drive gear screw	2	2	1/4(40)×7
G11	7.02.04.026	Bearing	1	1	51101
G12	7.02.15.439	Felt fixed screw	1	1	M5×8
G13		Felt	1	1	
G14	7.02.09.031	Hook saddle bearing cover	1	1	
G15	7.02.04.032	Bearing	2	2	608
G16	7.02.15.438	Bearing cover screw	2	2	M4(0.5)×7
G17	7.02.13.046	Hook saddle	1	1	
G18	7.02.15.445	Hook saddle fixed screw	2	2	M6×25
G19		Felt	1	1	
G20	7.02.10.098	Elasticity pin	1	1	
G21	7.02.07.057	Hook gear	1	1	
G22	7.02.18.027	Elasticity stop ring	1	1	GB/T893.1-1986- 22
G23	7.02.02.092	Hook	1	1	
G24	7.02.21.144	Bobbin	1	1	
G25		Bobbin case	1	1	
G26	7.02.02.094	Hook orientation claw	1	1	
G27	7.02.15.006	Hook orientation claw screw	5	5	M4×8
G28	7.02.02.091	Hook thread distributing claw	1	1	
G29	7.02.10.099	Hook thread distributing bracket	1	1	
G30	7.02.08.110	Hook thread distributing bracket bushing	1	1	
G31	7.02.15.440	Bushing tighten screw	1	1	M6(0.75)×3.5
G32	7.02.18.084	Hook saddle bottom cover washer	1	1	
G33		Felt	1	1	
G34	7.02.13.047	Hook saddle bottom cover	1	1	
G35	7.02.16.075	Hook cooper oil tube	1	1	
G36		Hook oil wick	1	1	
G37	7.02.15.441	Oil seal screw	1	1	M6×5

H、 Thread trimming parts

No.	PartNo.	Name	Qty.		Remark
			82800	82800-D	
H01	7.02.19.032	Thread trimming electromagnetic		1	
H02	7.02.15.037	Thread trimming electromagnetic screw		4	M3×6
H03	7.02.18.123	Thread trimming electromagnetic screw washer		4	GB/T97.1 3
H04	7.02.17.125	Thread trimming electromagnetic fixed plate		1	
H05	7.02.15.032	Thread trimming electromagnetic fixed plate screw		2	M4×8
H06	7.02.05.163	Thread trimming electromagnetic link lever		1	
H07	7.02.10.136	Thread trimming electromagnetic link lever pin		1	
H08	7.02.18.024	E-ring		3	GB/T896-1986-3
H09	7.02.15.096	Thread trimming parts setting bracket screw		3	M5×16
H10	7.02.13.073	Thread trimming parts setting bracket		1	
H11	7.02.15.268	Crank connection screw/nut		3	GB/T6170 M4
H12	7.02.06.075	Link lever crank (upper)		1	
H13	7.02.10.137	Link lever crank pin		1	
H14	7.02.15.097	Crank connection screw		2	M4×6.5
H15	7.02.17.018	Replacement spring		2	
H16	7.02.10.144	Replacement spring pin		1	
H17	7.02.15.006	Link lever crank pin screw		11	M4×8
H18	7.02.11.101	Release soft-shaft fixed press plate		1	
H19	7.02.11.100	Release soft-shaft fixed plate		1	
H20	7.02.05.172	Link lever		1	
H21	7.02.06.076	Link lever crank (lower)		1	
H22	7.02.15.416	Link lever crank (lower) screw		2	M5×12
H23	7.02.12.073	Stopper block		1	
H24	7.02.15.430	Stopper block screw		3	M5×10
H25	7.02.06.077	Release crank		1	
H26	7.02.16.122	Release soft-shaft connection		1	
H27	7.02.06.078	Thread trimming drive crank		1	
H28	7.02.03.111	Thread trimming crank shaft		1	
H29	7.02.18.039	E-ring		1	GB/T896-1986-5
H30	7.02.06.079	Thread trimming vibrating crank		1	
H31	7.02.10.139	Thread trimming drive crank pin		1	
H32	7.02.10.138	Thread trimming vibrating crank pin		1	
H33	7.02.18.031	E-ring		6	GB/T896-1986-4
H34	7.02.18.016	Washer		1	GB/T97.1 5
H35	7.02.17.019	Replacement spring		1	
H36	7.02.18.071	Washer		1	GB/T97.1 4
H37	7.02.15.099	Thread trimming link lever adjustive screw		1	

H. Thread trimming parts

No.	PartNo.	Name	Qty.		Remark
			82800	82800-D	
H38	7.02.15.098	Thread trimming vibrating crank stopper screw		1	M4×20
H39	7.02.05.173	Thread trimming link lever (right)		1	
H40	7.02.10.140	Thread trimming link lever pin		2	
H41	7.02.10.141	Thread trimming link and vibrating lever pin		1	
H42	7.02.08.039	Thread trimming link and vibrating lever pin bushing		1	
H43	7.02.05.177	Thread trimming link and vibrating lever		1	
H44	7.02.05.093	Thread trimming link lever tie-in		2	
H45	7.02.10.193	Thread trimming link lever joint lever		1	
H46	7.02.15.622	Thread trimming link lever nut (left)		1	M5(left)
H47	7.02.05.171	Thread trimming link lever (left)		1	
H48	7.02.15.068	Thread trimming link lever nut		1	GB/T6170 M5
H49	7.02.05.174	Thread trimming vibrating lever		1	
H50	7.02.10.143	Thread trimming vibrating lever eccentricity pin		1	
H51	7.02.15.056	Thread trimming vibrating lever eccentricity pin screw		1	M5×6
H52	7.02.15.053	Thread trimming vibrating lever socket setting screw		3	M5×12
H53	7.02.13.074	Thread trimming vibrating lever socket		1	
H54	7.02.10.142	Thread trimming vibrating lever pin		1	
H55	7.02.18.059	Washer		1	
H56	7.02.21.085	E-ring		1	GB/T896-1986-9
H57	7.02.15.102	Movable knife support plate screw		2	M4×6.5
H58	7.02.11.103	Movable knife support plate		1	
H59	7.02.20.030	Movable knife		1	
H60	7.02.11.102	Movable knife guide plate		2	
H61	7.02.15.100	Movable knife guide plate screw		2	M4×4
H62	7.02.15.103	Fixed knife screw		1	
H63	7.02.20.031	Fixed knife		1	
H64	7.02.15.104	Thread trimming pressure adjustive screw		1	
H65	7.02.02.073	Slide plate		1	
H66	7.02.15.388	Slide plate screw		2	M4×8
H67	7.02.15.101	Movable knife assistant support plate screw		2	M3×4
H68	7.02.18.061	Spring washer		2	GB/T93. 3
H69	7.02.11.098	Movable knife assistant support plate		1	
H70		Felt		1	
H71	7.02.17.032	Release lever replacement spring		1	
H72	7.02.01.058	Release lever assy.		1	
H73	7.02.10.145	Release soft-shaft stopper pin		1	
H74	7.02.01.060	Flexible wire assy.		1	

I. Oil lubrication parts

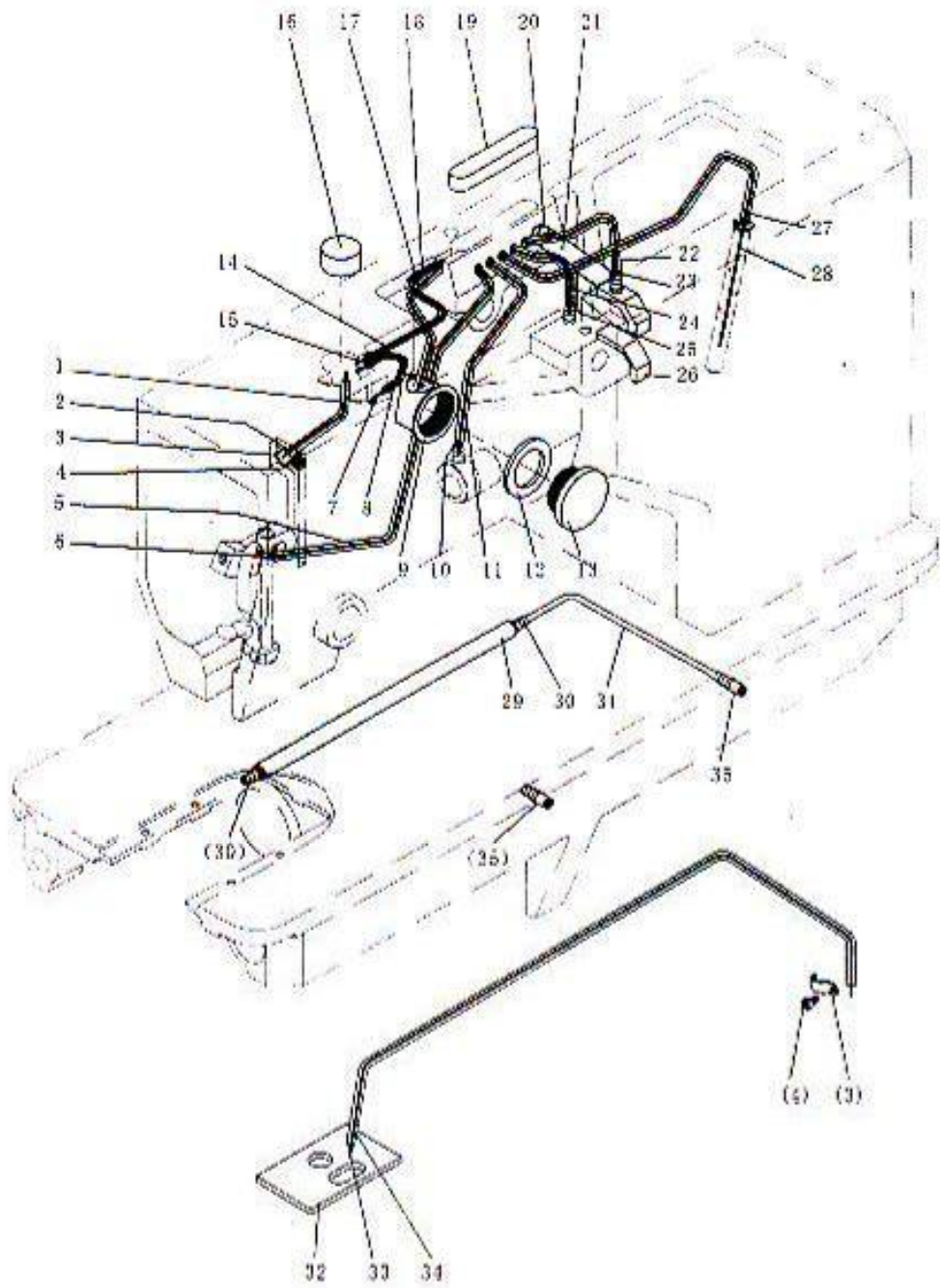

I. Oil lubrication parts

No.	PartNo.	Name	Qty.		Remark
			82800	82800-D	
101		Oil tube	1	1	Φ3/Φ5×65mm
102		Oil wick	1	1	Φ2×140mm
103	7.02.17.029	Oil tube clip	2	2	
104	7.02.15.037	Oil tube clip screw	2	2	M3×6
105		Oil tube	1	1	Φ3/Φ5×200mm
106		Oil wick	1	1	Φ2×250mm
107		Oil wick	1	1	Φ2×150mm
108		Oil tube	1	1	Φ3/Φ5×70mm
109	7.02.16.070	Oil window	1	1	
110		Oil wick	1	1	Φ2×200mm
111		Oil tube	1	1	Φ3/Φ5×130mm
112	7.02.16.071	Oil window cover washer	1	1	
113	7.02.16.069	Oil window cover	1	1	
114		Oil tube	1	1	Φ3/Φ5×110mm
115		Oil wick	1	1	Φ2×200mm
116		Felt	2	2	Φ16×12
117		Oil wick	1	1	Φ3×200mm
118		Oil tube	1	1	Φ3/Φ5×110mm
119		Felt	1	1	
120	7.02.15.044	Oil felt clip screw	1	1	M5×8
121	7.02.17.093	Oil felt clip	1	1	
122		Oil tube	1	1	Φ3/Φ5×100mm
123		Oil wick	1	1	Φ2×180mm
124		Oil tube	1	1	Φ3/Φ5×100mm
125		Oil wick	1	1	Φ2×160mm
126		Felt	1	1	
127		Oil tube	1	1	Φ3/Φ5×200mm
128		Oil wick	1	1	Φ2×300mm
129	7.02.16.073	Coppery oil tube	1	1	
130	7.02.16.060	Oil spile	2	2	
131		Oil tube	1	1	Φ3/Φ5×50mm
132		Felt	1	1	
133		Oil wick	1	1	Φ2×640mm×2
134		Oil tube	1	1	Φ3/Φ5×600mm
135	7.02.16.059	Oil spile	2	2	

J. Accessories

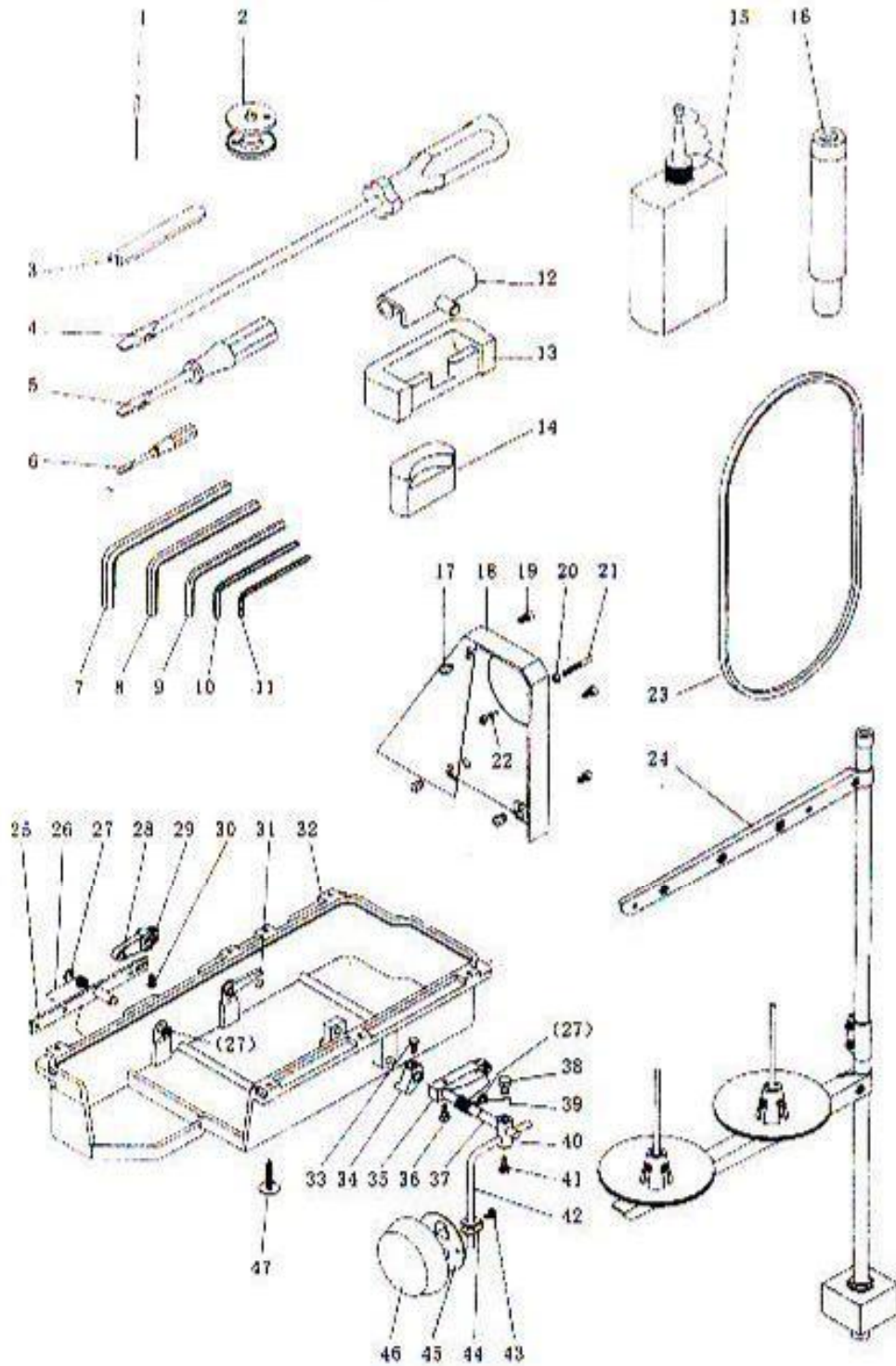

J. Accessories

No.	PartNo.	Name	Qty.		Remark
			82800	82800-D	
J01	7.02.21.140	Needle	4	4	19'
J02	7.02.21.144	Bobbin	4	4	
J03	7.02.21.142	Open end wrench	1	1	
J04	7.02.21.003	Screw driver (big)	1	1	
J05	7.02.21.002	Screw driver (middle)	1	1	
J06	7.02.21.001	Screw driver (small)	1	1	
J07	7.02.21.238	Hexagonal Wrench		1	6mm
J08	7.02.21.100	Hexagonal Wrench	1	1	5mm
J09	7.02.21.099	Hexagonal Wrench		1	4mm
J10	7.02.20.209	Hexagonal Wrench		1	3mm
J11	7.02.21.299	Hexagonal Wrench		1	2.5mm
J12	7.02.21.080	Hinge	2	2	
J13	7.02.21.079	Hinge cover	2	2	
J14	7.02.21.291	Vibration preventing rubber	2	2	
J15	7.02.21.008	Small oil pot	1	1	
J16	7.02.21.147	Crosstie	1	1	
J17	7.02.18.077	Rubber pad	3	3	
J18	7.02.21.136	Belt cover	1	1	
J19		Belt cover screw	3	3	M6×10
J20	7.02.21.138	Nut	2	2	M5
J21	7.02.21.137	Screw	1	1	
J22	7.02.21.139	Spring washer	1	1	
J23	7.02.21.095	Belt	1	1	
J24	7.02.21.050	Thread stand	1	1	
J25	7.02.21.171	Foot control backstitch lever	1		
J26	7.02.21.172	Replacement spring	1		
J27	7.02.18.021	E-ring	3		GB/T896-1986-9
J28	7.02.21.175	Foot control backstitch crank pin	1		
J29	7.02.21.173	Foot control backstitch crank	1		
J30	7.02.21.174	Foot control backstitch crank screw	1		
J31	7.02.21.176	Knee lifting Lever assy,	1		
J32	7.02.21.164	Oil reservoir	1		
J33	7.02.21.162	Knee lifting orientation block screw	1		
J34	7.02.21.165	Knee lifting orientation block	1		
J35	7.02.21.153	Roller joint	1		
J36		Roller joint screw	1		
J37	7.02.21.168	Straight lever	1		