

零件手册

PARTS BOOK

1. 机身部件

Housing sections

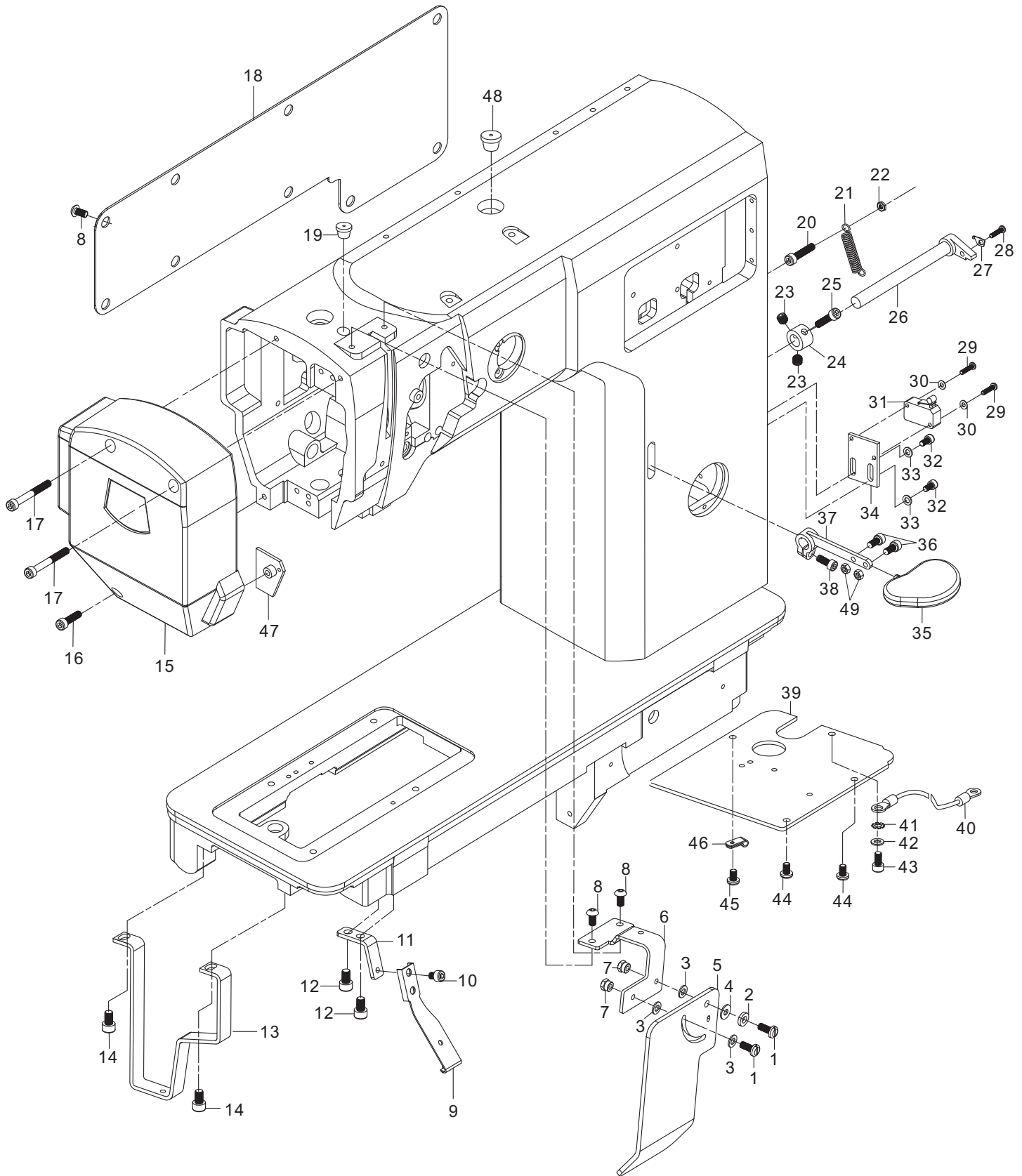

1. 机身部件

Housing sections

序号 No.	件号 Part No.	名称	DESCRIPTION	数量 Qty
1	10005271	螺钉 M5×12	Screw M5×12	2
2	10003235	垫圈 Φ5	Washer Φ5	1
3	10005016	垫圈 Φ5	Washer Φ5	4
4	10001413	垫圈 Φ5	Washer Φ5	1
5	10001607	防护板	Protection apron	1
6	20003964	防护板支架	Protection apron bracket	1
7	10003021	螺母 M5	NUT M5	2
8	10007096	螺钉 M5×10	Screw M5×10	11
9	10005187	安全板	Safety plate	1
10	10005539	螺钉 M5×6	Screw M5×6	1
11	10005008	支板	Trestle board	1
12	10005122	螺钉 M6×10	Screw M6×10	2
13	10054582	支脚	Bracket	1
14	10004974	螺钉 M6×10	Screw M6×10	2
15	10057383	步进机面板	Panel	1
16	10003141	螺钉 M5×20	Screw M5×20	1
17	10041446	螺钉 M5×45	Screw M5×45	2
18	20021234	侧盖板	Lateral board	1
19	10005124	油塞	Oil dam	1
20	10007637	螺钉 M5×40	Screw M5×40	1
21	10041260	倒缝杆弹簧	Spring	1
22	10002952	螺母 M5	NUT M5	1
23	10011802	SM11/64"×40螺钉	Screw SM11/64"×40	2
24	10000378	倒送料轴挡圈	Thrust collar for feeding axis	1
25	10000560	SM11/64"×40螺钉	Screw SM11/64"×40	1
26	10057382	倒缝扳手轴	Axis of spanner for reversal stitch	1
27	10005287	弹簧固定板	Spring fix board	1
28	10005186	螺钉 M4×8	Screw M4×8	1
29	10001368	螺钉 M3×14	Screw M3×14	2
30	10002068	垫圈 Φ3	Washer Φ3	2
31	10035679	倒缝点动开关	Power switch	1
32	10005350	螺钉 M4×8	Screw M4×8	2
33	10005260	垫圈 Φ4	Washer Φ4	2
34	10057392	开关安装板	Mounting plate	1
35	10057379	倒缝扳手	Spanner of reversal stitch	1
36	10012752	螺钉 M4×10	Screw M4×10	2
37	10057380	扳手挡圈	Thrust collar for spanner	1
38	10005139	螺钉 M5×12	Screw M5×12	1
39	10041476	底板盖板	Bottom cover	1
40	10005458	接地线组件	Ground lead	1
41	10005425	外齿锁紧垫圈 Φ5	Washer Φ5	1
42	10005016	垫圈 Φ5	Washer Φ5	1
43	10005322	螺钉 M5×10	Screw M5×10	1
44	10005003	螺钉 M5×8	Screw M5×8	2
45	10005513	螺钉 M4×8	Screw M4×8	1
46	10008228	SN-3A夹头	Clamp	1
47	10001414	面板油箱盖	Plate of panel lube tank	1
48	10005501	油塞	Oil dam	1
49	10003027	螺母M4	NUT M4	2

2. 机头零件(1) Needle head parts (1)

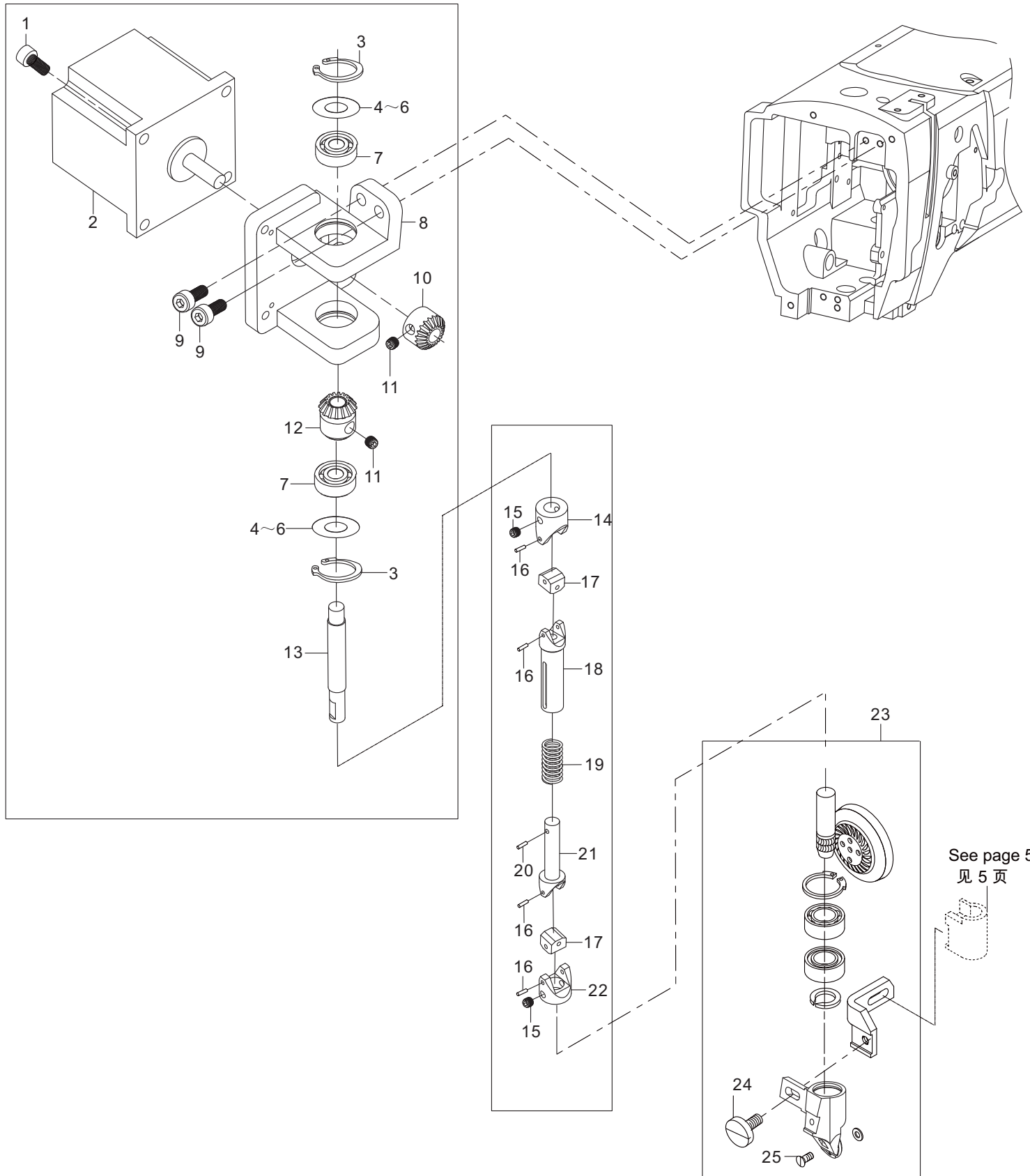

2. 机头零件 (1)

Needle head parts (1)

序号 No.	件号 Part No.	名称	DESCRIPTION	数量 Qty
1	10059082	M5×16螺钉	Screw M5×16	3
2	10062956	送料步进电机	Feeding stepping motor	1
3	10052006	挡圈	Retaining ring	2
4	10057361	调节垫片 0.15	Adjusting washer 0.15	2
5	10057362	调节垫片 0.3	Adjusting washer 0.3	2
6	10057363	调节垫片 0.5	Adjusting washer 0.5	2
7	10027118	轴承	Bearing	2
8	10057360	上送料支座	Above feeding support	1
9	10003164	螺钉 M5×16	Screw M5×16	2
10	10008672	574倒缝传动齿轮 II	574 Backstitch transmission gear	1
11	10005549	M6×5螺钉	Screw M6×5	4
12	10007075	574倒缝传动齿轮 I	574 Backstitch transmission gear	1
13	10062393	转轴A	Axis A	1
14	10056359	万向头A	Universal joint A	1
15	10009741	M4×6螺钉	Screw M4×6	2
16	10039834	滚针P2×11.8	Needle roller P2×11.8	4
17	10056362	联接块	Connecting block	2
18	10056357	万向连杆	Universal connecting rod	1
19	10053250	压缩弹簧	Pressure spring	1
20	10053251	滚针P2.5×13.8	Needle roller P2.5×13.8	1
21	10056358	万向轴	Idler wheel foot asm	1
22	10056360	万向头B	Universal joint B	1
23	10056370	滚轮压脚组件	Idler wheel foot asm	1
24	10005243	螺钉 M4×8	Screw M4×8	1
25	10005070	螺钉 M2.5×6	Screw M2.5×6	1

3. 机头零件(2) Needle head parts (2)

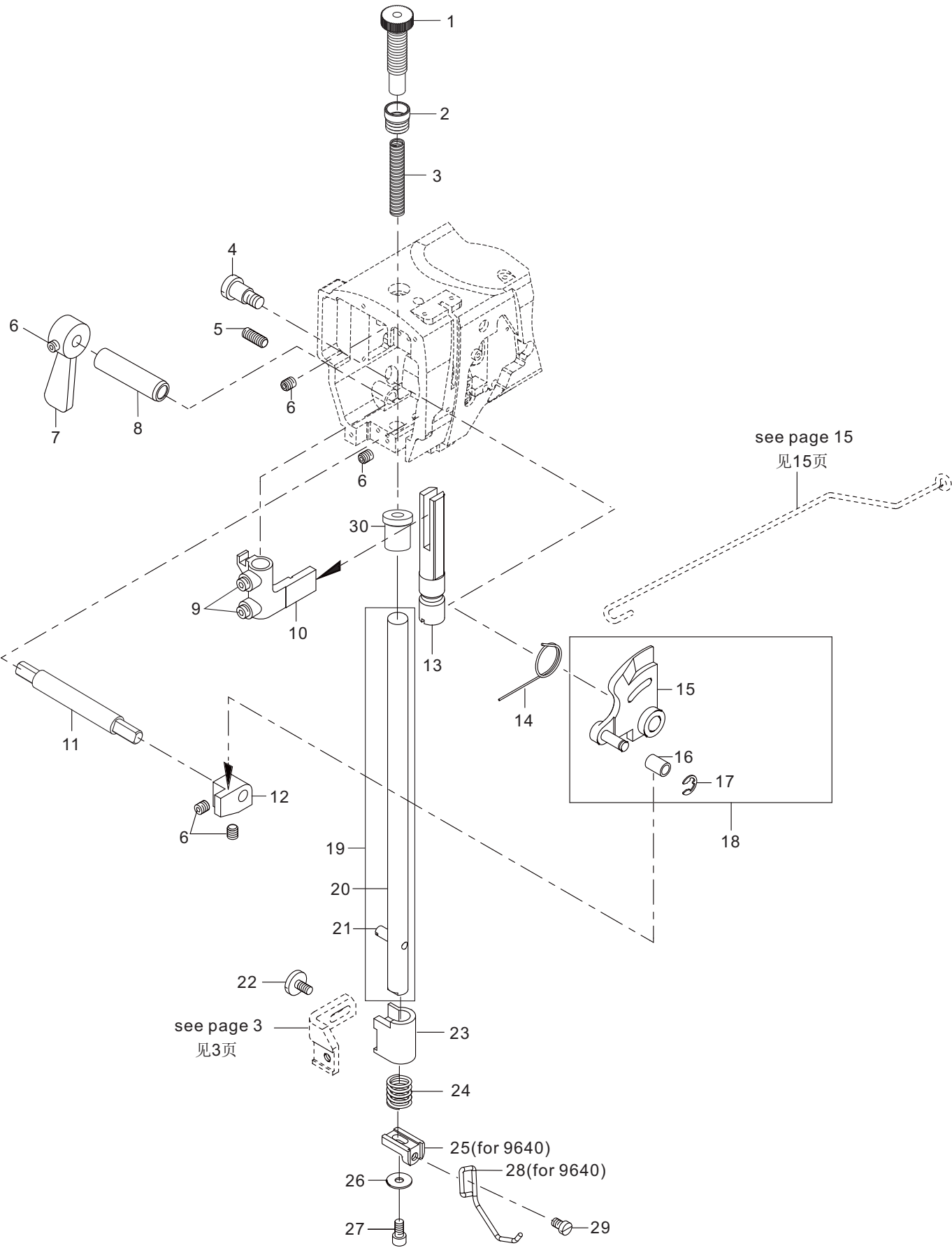

3. 机头零件 (2)

Needle head parts (2)

序号 No.	件号 Part No.	名称	DESCRIPTION	数量 Qty
1	10057364	调压螺钉	Adjusting pressure screw	1
2	10057365	调压锁紧螺母	Adjusting pressure jam nut	1
3	10057366	压紧弹簧	Compress spring	1
4	10005312	螺钉 M6×8	Screw M6×8	1
5	10009187	螺钉 M6×8	Screw M6×8	1
6	10012162	螺钉 M5×5	Screw M5×5	5
7	20003486	压脚扳手	Presserfoot spanner	1
8	10005412	抬压脚手柄轴套	Presser feet handle bushing	1
9	10005549	螺钉 M6×5	Screw M6×8	2
10	10005208	压杆滑块	Strut bar slides	1
11	10005011	抬压脚轴	Presser foot lift axle	1
12	10005543	抬压脚凸块	Presser foot lift bump	1
13	10005192	压杆滑块导杆	Strut bar slides guide bar	1
14	10005418	松线复位簧	Replacement spring	1
15	10005239	抬压脚前杠杆焊接件	Presser foot lift jointing	1
16	10005406	抬压脚前杠杆销套	Presser foot lift pin	1
17	10005078	挡圈	Collar	1
18	10039313	抬压脚前杠杆组件	Presser foot lift asm	1
19	10005178	压脚杆组件	Presser feet assembly	1
20	10005247	压脚杆	Presser feet	1
21	10005422	下节销螺钉 M4×5.2	Screw M4×5.2	1
22	10005243	螺钉 M4×8	Screw M4×8	1
23	10005068	压脚柄	Presser feet handle	1
24	10005460	压簧	Pressure spring	1
25	10001492	压料器定位座 (for 9640)	Eccentric swage locating seat (for 9640)	1
26	10005415	垫圈 Φ4	Washer Φ4	1
27	10005350	螺钉 M4×8	Screw M4×8	1
28	10030364	压料簧 (for 9640)	Eccentric swage spring (for 9640)	1
29	10005204	螺钉 M4×6	Screw M4×6	1
30	10057367	压杆下套	Presser busing	1

4. 机头零件(3) Needle head parts (3)

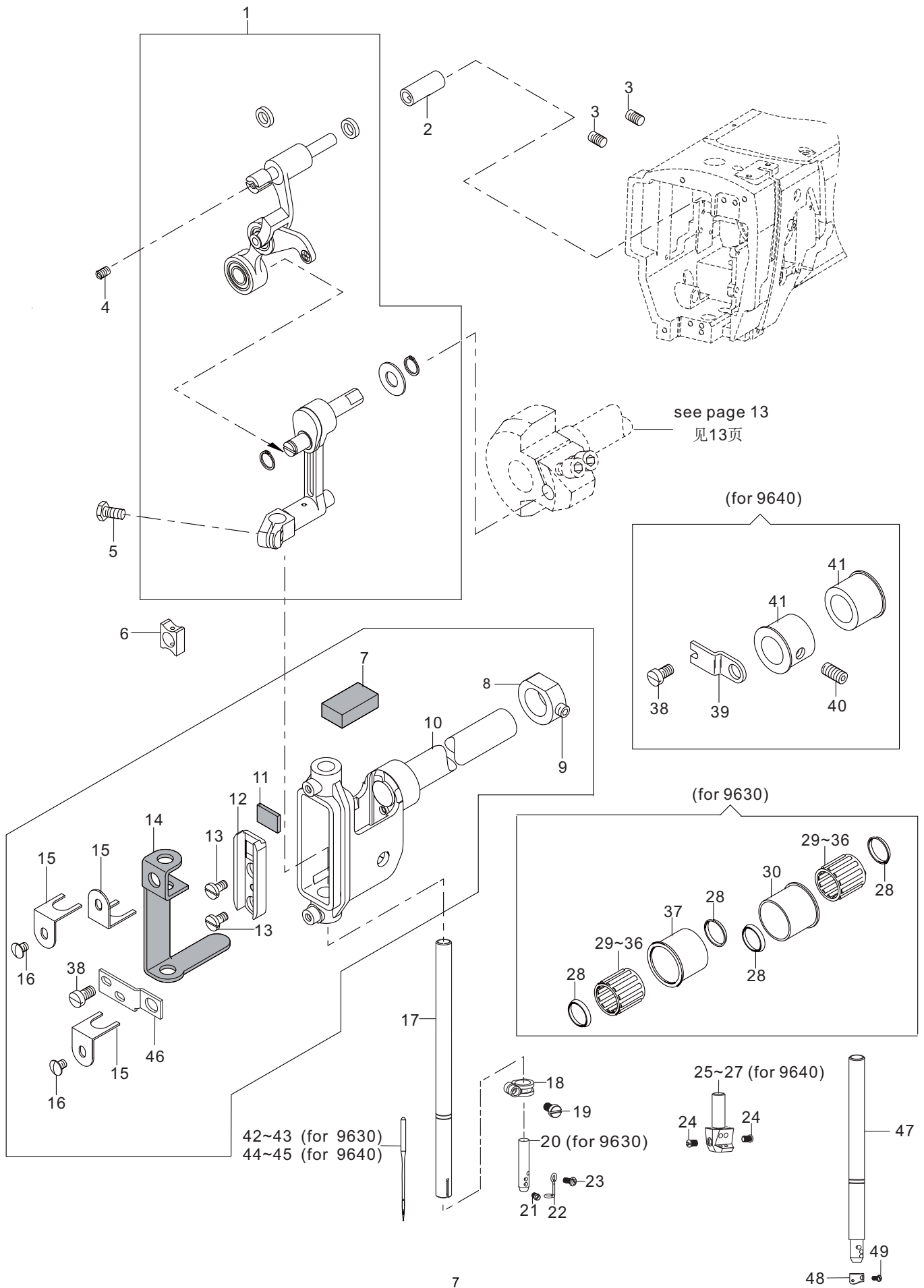

4. 机头零件 (3)

Needle head parts (3)

序号 No.	件号 Part No.	名称	DESCRIPTION	数量 Qty
1	10005207	挑线杆组件	Takeuplever assembly	1
2	10005267	挑线连杆销衬套	Takeuplever pin bushing	1
3	10004949	螺钉 M5×8	Screw M5×8	2
4	10005295	螺钉 M4×5	Screw M4×5	1
5	10005314	螺栓 M5×10	Screw M5×10	1
6	10005326	针杆连接柱滑块	Needle joining slider	1
7	10005275	油毡	Felt	1
8	10040233	针杆架轴挡圈	Uper check ring	1
9	10005258	螺钉 M6×0.75×5	Screw M6×0.75×5	1
10	10005397	针杆架件	Needle bar assembly	1
11	10005188	油毡	Felt	1
12	10005263	针杆滑块槽	Needle slider groove	1
13	10005379	螺钉 M4×4.5	Screw M4×4.5	2
14	10004947	油毡	Felt	1
15	10005197	油毡压板	Linoleum clamp	3
16	10005050	螺钉 M4×4	Screw M4×4.5	1
17	10005491	针杆上节	Needle bar uper	1
18	10005181	针杆锁紧圈	Needle bar clamp ring	1
19	10005209	螺钉 M4×8	Screw M4×8	1
20	10005214	针杆下节 (For 9630)	Pin chuck (for 9630)	1
21	10005478	机针锁紧螺钉 M4×8	Screw M4×8	1
22	10004943	下过线钩	Arm thread guide	1
23	10005547	螺钉 M3×6	Screw M3×6	1
24	10001578	螺钉 M3×3.2	Screw M3×3.2	2
25	10001494	3.2针夹头 (For 9640)	Pin chuck 3.2 (For 9640)	(1)
26	10002199	2.8针夹头 (For 9640)	Pin chuck 2.8 (For 9640)	(1)
27	10001421	2.4针夹头 (For 9640)	Pin chuck 2.4 (For 9640)	(1)
28	10005031	内卡圈	Inner retainer ring	4
29	10005408	滚针轴承	Needle bearing	(2)
30	10007188	滚针轴承	Needle bearing	(2)
31	10007189	滚针轴承	Needle bearing	(2)
32	10007190	滚针轴承	Needle bearing	(2)
33	10007191	滚针轴承	Needle bearing	(2)
34	10007192	滚针轴承	Needle bearing	(2)
35	10007193	滚针轴承	Needle bearing	2
36	10007194	滚针轴承	Needle bearing	(2)
37	10004952	上边轴轴承套	Bearing bush	2
38	10001493	螺钉 M5×6	Screw M5×6	2
39	10008050	定位板	Guide plate	1
40	10002163	螺钉 M6×14	Screw M6×14	1
41	10008049	针杆架轴套	Needle bar bush	2
42	10006103	机针134PCL90/14 (for 9630-M)	Neddle 134PCL 90/14 (for 9630-M)	1
43	10004103	机针134PC120/19 (for 9630-H)	Neddle 134PCL 120/19 (for 9630-H)	(1)
44	10001375	机针134-35 90/14 (for 9640-M)	Neddle 134-35 90/14 (for 9640-M)	2
45	10030202	机针134-35120/19 (for 9640-H)	Neddle 134-35 120/19 (for 9640-H)	(2)
46	10057385	摆针限位板	Neddle limit board	1
47	10059855	单针针杆B	Needle bar B	1
48	10013181	针杆线钩	Thread hook	1
49	10005478	M3×4螺钉	Screw M3×4	1

5. 机头零件(4) Needle head parts (4)

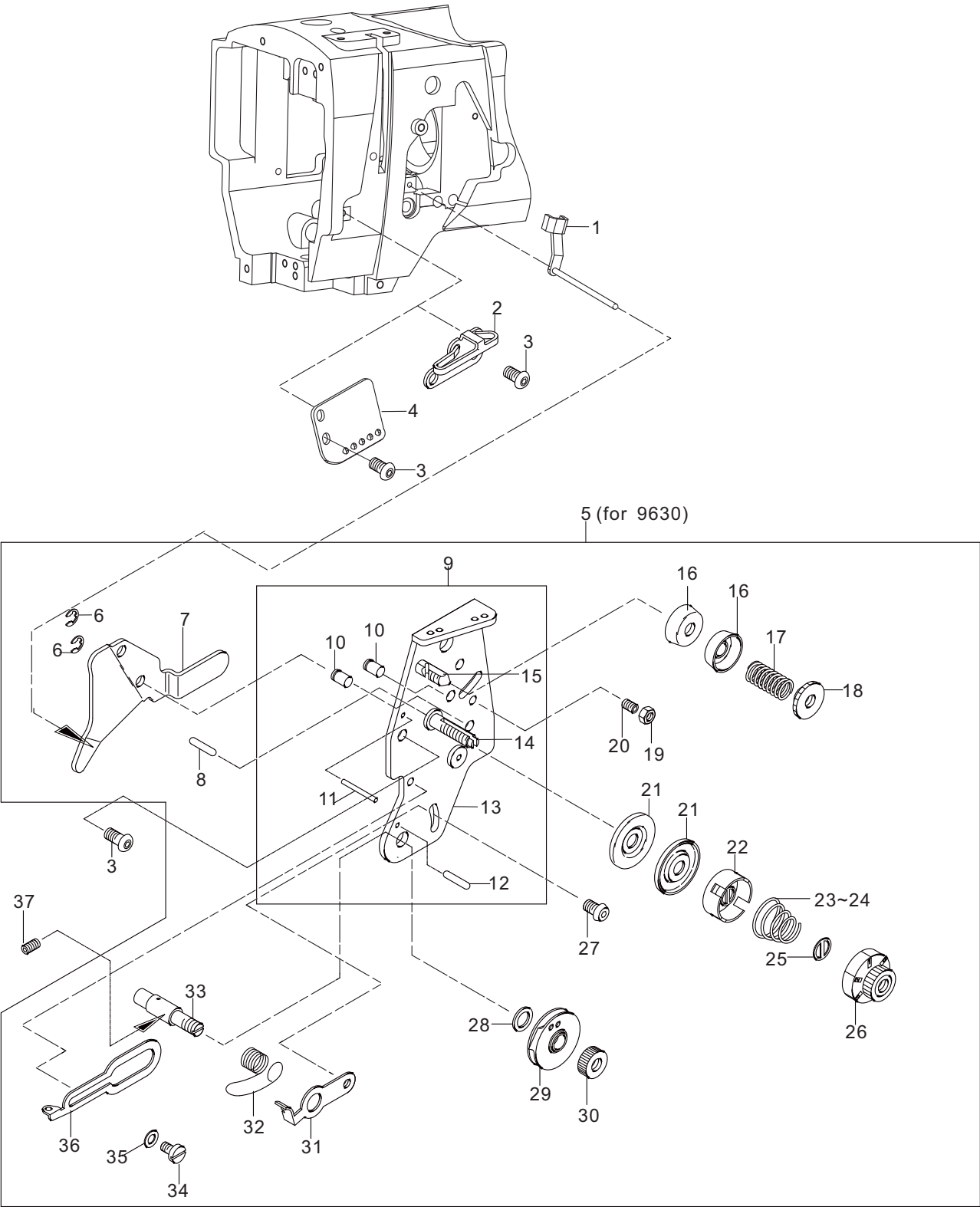

5. 机头零件 (4)

Needle head parts (4)

序号 No.	件号 Part No.	名称	DESCRIPTION	数量 Qty
1	10001657	电磁铁挺线钉	Tension release crank	1
2	10005118	左右过线勾	Left and right wire hook	1
3	10007096	螺钉 M5×10	Screw M5×10	4
4	10052849	大过线勾	Thread guide plate	1
5	10004080	夹线器 (9630专用)	Conductor holder for 9630	1
6	10009669	卡圈	Collar	2
7	10004977	挑线簧限位板	Spring guard	1
8	10005252	过线钉	Pin	1
9	10005302	夹线大板组件	Bobbin winder tension disc asm	1
10	10005032	销钉 5×8	Screw pin 5×8	2
11	10005289	防转长销钉 2×20	Screw pin 5×8	1
12	10005316	防转销钉 2×8	Screw pin 5×8	1
13	10004941	夹线大板	Bobbin winder tension disc	1
14	10005554	螺钉	Screw	1
15	10005548	夹线调压螺钉	Screw	1
16	10005019	调节簧座	Thred tension disk	2
17	10005241	夹线调节弹簧	Spring	1
18	10005190	夹线调节螺母 M6	Screw M6	1
19	10005328	挺线电磁铁调节螺母 M4	Screw M4	1
20	10003147	螺钉 M4×8	Screw M4×8	1
21	10005489	过线板	Thread guide plate	2
22	10005210	夹线簧座	Split line spring plate	1
23	10005014	夹线簧-薄料 (—M机型)	Split line spring (for —M Model)	1
24	10005347	夹线簧-厚料 (—H机型)	Split line spring (for —H Model)	(1)
25	10005317	压簧板	Spring plate	1
26	10005304	夹线螺母	NUT	1
27	10005107	螺钉 M4×6	Screw M4×6	1
28	10005056	垫片 Φ7.3	Washer Φ5	1
29	10005329	挑线过线焊件	Balance thread guide	1
30	10005538	挑线簧组件螺母 M6×0.75	NUT M6×0.75	1
31	10005417	挡簧块	E-ring	1
32	10005067	挑线簧	Spring	1
33	10005505	夹线过线轴	Thread guide spindle	1
34	10005299	螺钉 M4×5	Screw M4×6	1
35	10003122	垫圈 Φ4	Washer Φ4	1
36	10005429	过线调节板	Thread guide plate	1
37	10004949	螺钉 M5×8	Screw M4×6	1

6. 机头零件(5) Needle head parts (5)

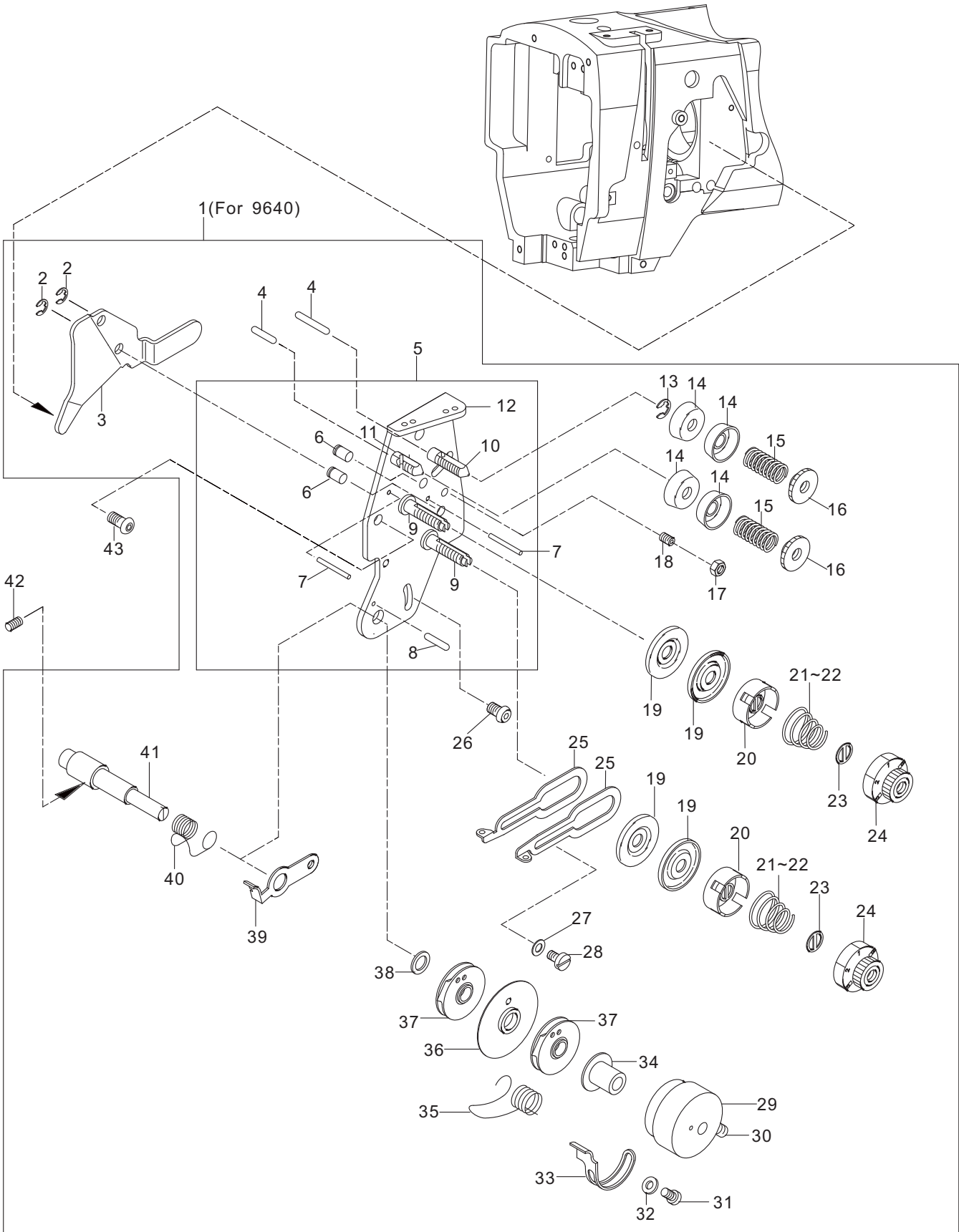

6. 机头零件 (5)

Needle head parts (5)

序号 No.	件号 Part No.	名称	DESCRIPTION	数量 Qty
1	10014515	夹线器 (9620专用)	Conductor holder (for 9620)	1
2	10009669	卡圈	Collar	2
3	10004977	挑线簧限位板	Spring guard	1
4	10005252	过线钉	Pin	1
5	10005302	夹线大板组件	Bobbin winder tension disc asm	1
6	10005032	销钉 5×8	Screw pin 5×8	2
7	10005289	防转长销钉 2×20	Screw pin 2×20	2
8	10005316	防转销钉 2×8	Screw pin 2×8	1
9	10005554	螺钉	Screw	2
10	10001534	夹线调压螺钉 I	Screw	1
11	10005548	夹线调压螺钉	Screw	1
12	10004941	夹线大板	Bobbin winder tension disc	1
13	10005078	卡圈	Collar	1
14	10005019	调节簧座	Thred tension disk	4
15	10005241	夹线调节弹簧	Spring	2
16	10005190	夹线调节螺母 M6	Nut M6	2
17	10005328	挺线电磁铁调节螺母 M4	Nut M4	1
18	10003147	螺钉 M4×8	Screw M4×8	1
19	10005489	过线板	Thread guide plate	4
20	10005210	夹线簧座	Split line spring plate	2
21	10005014	夹线簧-薄料 (—M机型)	Split line spring (for —M Model)	2
22	10005347	夹线簧-厚料 (—H机型)	Split line spring (for —H Model)	(2)
23	10005317	压簧板	Spring plate	2
24	10005304	夹线螺母	Nut	2
25	10005429	过线调节板	Thread guide plate	2
26	10005107	螺钉 M4×6	Screw M4×6	1
27	10003122	垫圈 Φ4	Washer Φ4	1
28	10005299	螺钉 M4×5	Screw M4×6	1
29	10001495	挑线簧调节转动套筒	Sleeve	1
30	10002856	螺钉 M4×4	Screw M4×6	1
31	10003034	螺钉 M3×5	Screw M3×5	1
32	10003071	垫圈 Φ3	Washer Φ3	1
33	10002009	挡簧块 I	E-ring I	1
34	10001496	套环	Pipe casing	1
35	10002404	挑线簧 I	Spring I	1
36	10001532	挑线簧隔板	Partition board	1
37	10005329	挑线过线焊件	Balance thread guide	2
38	10005056	垫片 Φ7.3	Washer Φ5	1
39	10005417	挡簧块	E-ring	1
40	10005067	挑线簧	Spring	1
41	10001531	挑线簧调节轴	Adjustment axle	1
42	10004949	螺钉 M5×8	Screw M4×6	1
43	10007096	螺钉 M5×10	Screw M5×10	1

7. 机臂零件(1) Arm parts (1)

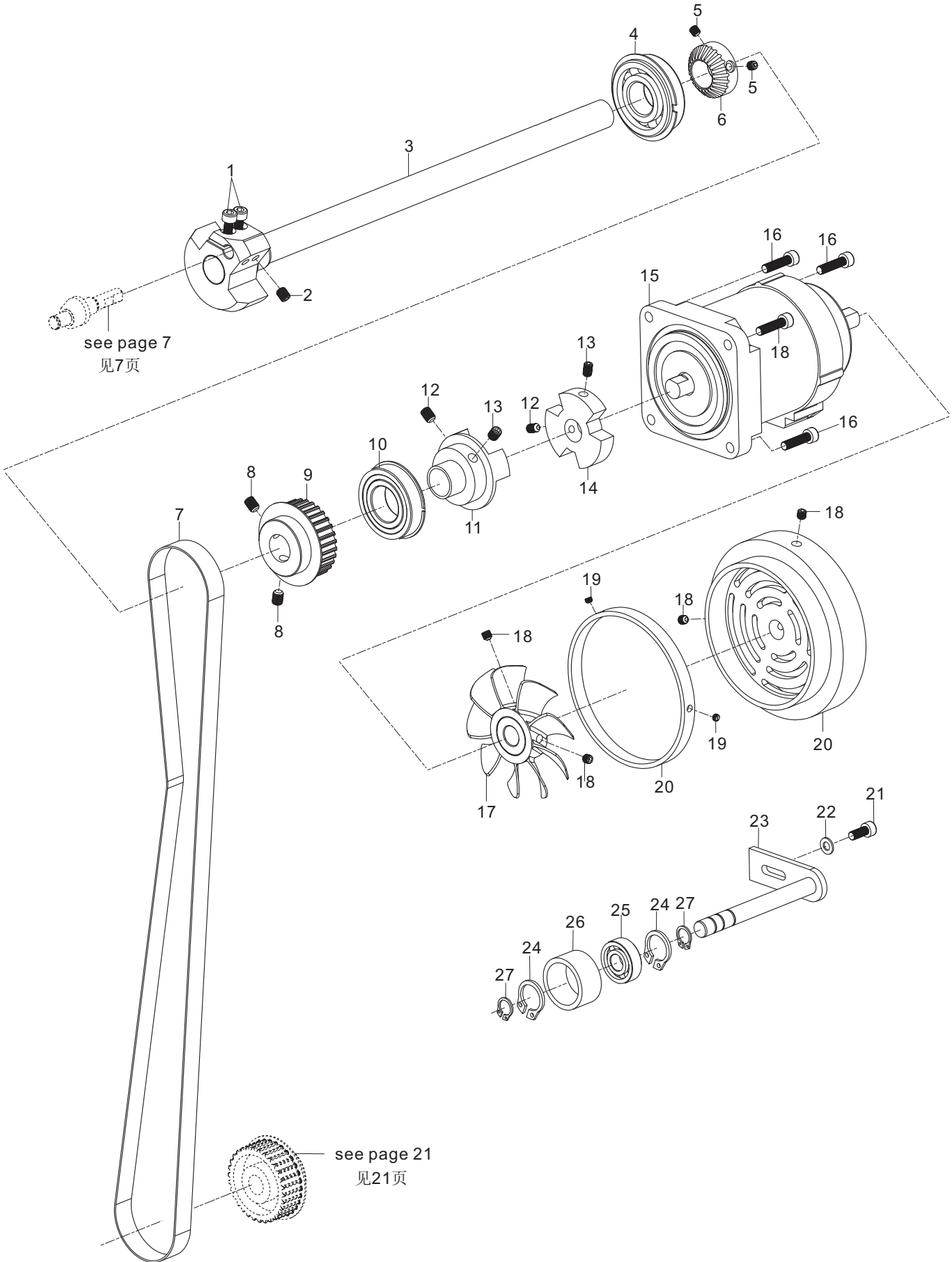

7. 机臂零件 (1)

Arm parts (1)

序号 No.	件号 Part No.	名称	DESCRIPTION	数量 Qty
1	10010953	螺钉 M5×10	Screw M5×10	2
2	10005466	螺钉 M6×0.75×7	Screw M6×0.75×7	1
3	10041482	曲柄主轴组件	Counter weight assy	1
4	10003578	主轴前轴承 6204ZZNR	Bearing 6204ZZNR	1
5	10012162	螺钉 M5×5	Screw M5×5	2
6	10054658	绕线主动轮	Pulley	1
7	10041479	一体机同步带	Synchronous belt	1
8	10009187	螺钉 M6×8	Screw M6×8	2
9	10041636	主轴宽带轮	Spindle Pulley	1
10	10041481	轴承NSK 60/22ZZNR	Bearing 60/22ZZNR NSK	1
11	10041480	主轴联轴器	Coupling	1
12	10005300	螺钉 M6×0.75×8	Screw M6×0.75×8	2
13	10004938	螺钉 M6×0.75×8	Screw M6×0.75×8	2
14	10042979	电机联轴器组件	Coupling rubber	1
15	10062954	主轴电机	Axis Motor	1
16	10000157	螺钉 M5×18.5	Screw M5×18.5	4
17	10041729	一体机风扇	Fan	1
18	10004949	螺钉 M5×8	Screw M5×5	4
19	10006279	螺钉 M4×2.8	Screw M4×2.8	2
20	20018197	一体机手轮喷漆	Uppper wheel	1
21	10005139	螺钉 M5×12	Screw M5×12	1
22	10005016	垫圈 Φ5	Washer Φ5	1
23	10057391	同步带压紧焊接件	Seal part	1
24	10027928	挡圈	Collar	2
25	10003576	轴承 6000ZZ	Bearing 6000ZZ	1
26	10005396	皮带压紧器轴承套	Bearing bush	1
27	10004945	挡圈	Collar	2

8. 机臂零件(2) Arm parts (2)

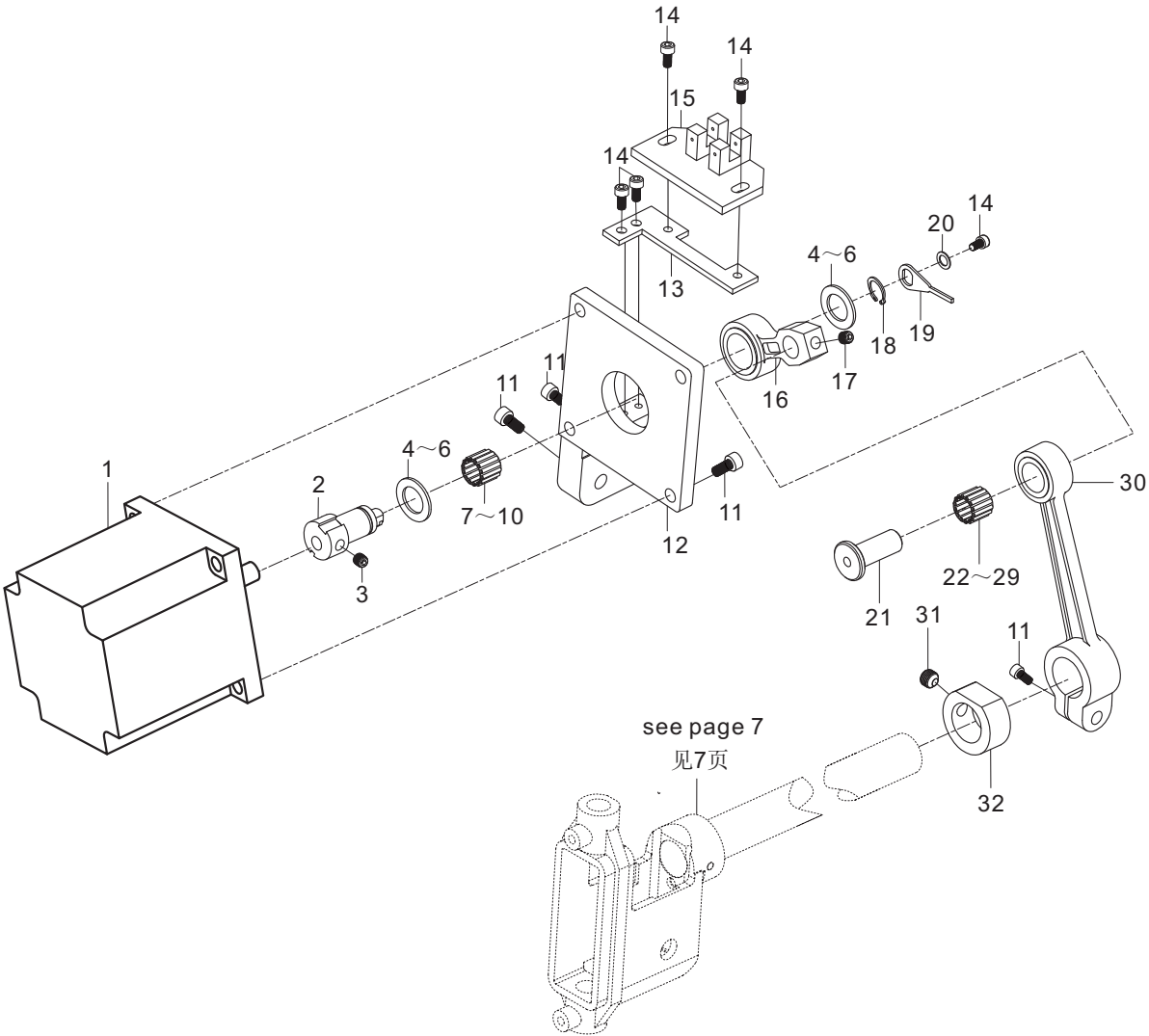

8. 机臂零件 (2)

Arm parts (1)

序号 No.	件号 Part No.	名称	DESCRIPTION	数量 Qty
1	10062955	摆针步进电机	Stepping motor	1
2	10057369	偏心轴	Ecentric axis	1
3	10009741	M4×6螺钉	Screw M4×6	1
4	10057374	Φ10垫片	Washer Φ10	2
5	10063319	Φ10垫片	Washer Φ10	(2)
6	10063320	Φ10垫片	Washer Φ10	(2)
7	10057525	K10×13×10滚针轴承	Needle bearing K10×13×10	1
8	10057526	K10×13×10滚针轴承	Needle bearing K10×13×10	(1)
9	10057371	K10×13×10滚针轴承	Needle bearing K10×13×10	(1)
10	10057372	K10×13×10滚针轴承	Needle bearing K10×13×10	(1)
11	10005139	M5×12螺钉	Screw M5×12	4
12	10057368	针送电机座	Motor support	1
13	10057375	传感器安装板	Plate for install sensor	1
14	10002975	M3×6螺钉	Screw M3×6	5
15	10063777	传感器	Sensor	1
16	10057370	曲柄连杆	Reciprocation rod	1
17	10004949	M5×8螺钉	Screw M5×8	1
18	10003277	挡圈	Thrust collar	1
19	10057376	传感片	Sensor pieces	1
20	10062255	传感片垫圈	Washer	1
21	10005047	针距调节连杆销	Pin	1
22	10005035	K8×11×10滚针轴承	Needle bearing K8×11×10	(1)
23	10007195	K8×11×10滚针轴承	Needle bearing K8×11×10	(1)
24	10007196	K8×11×10滚针轴承	Needle bearing K8×11×10	(1)
25	10007197	K8×11×10滚针轴承	Needle bearing K8×11×10	(1)
26	10007198	K8×11×10滚针轴承	Needle bearing K8×11×10	(1)
27	10007199	K8×11×10滚针轴承	Needle bearing K8×11×10	(1)
28	10007367	K8×11×10滚针轴承	Needle bearing K8×11×10	(1)
29	10007368	K8×11×10滚针轴承	Needle bearing K8×11×10	(1)
30	10057373	针送连杆	Needle feeding connecting rod	1
31	10005258	M6×0.75×5螺钉	Screw M6×0.75×5	1
32	10040233	针杆架轴挡圈	Thrust collar	1

9. 机臂零件(3) Arm parts (3)

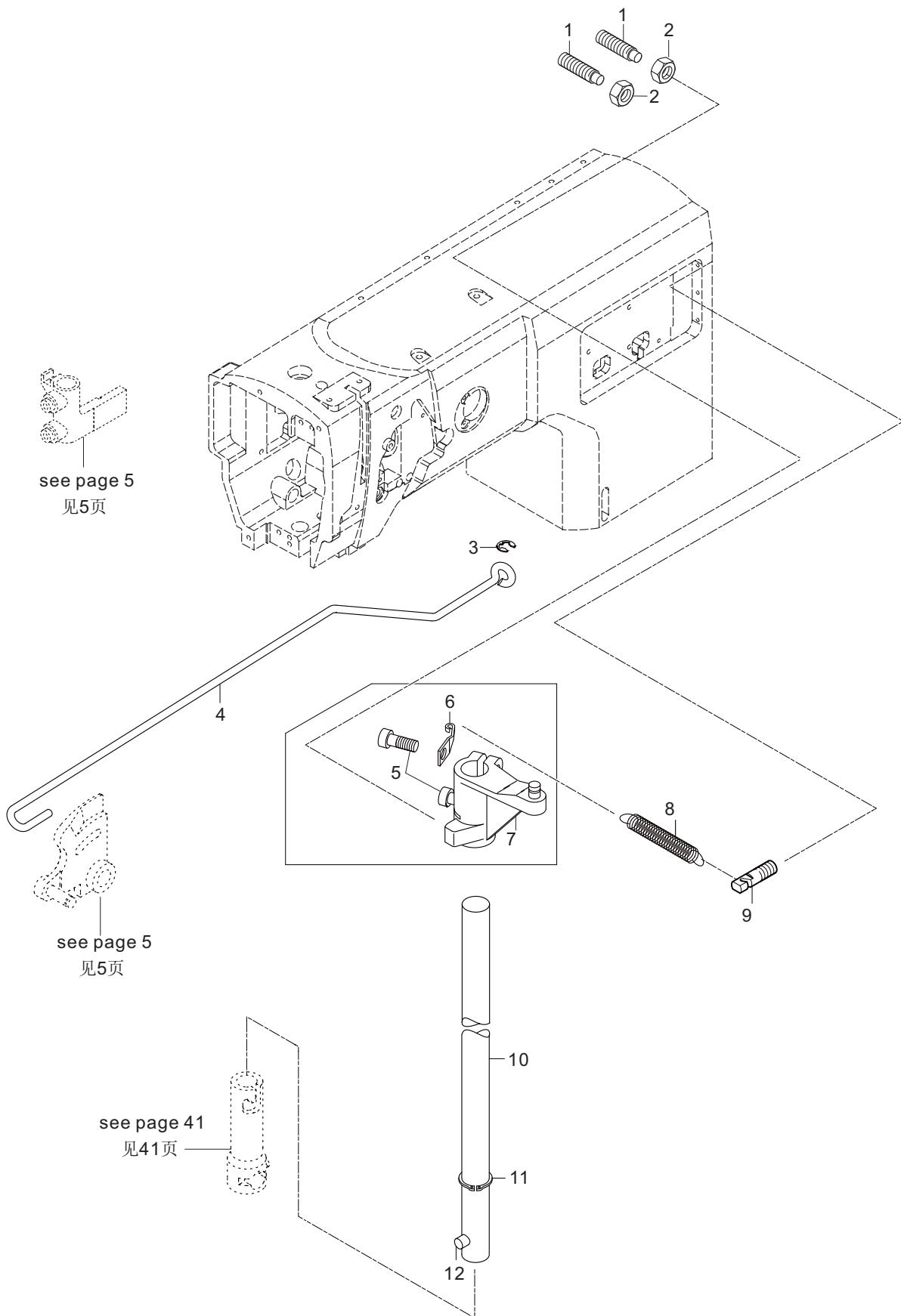

9. 机臂零件 (3)

Arm parts (3)

序号 No.	件号 Part No.	名称	DESCRIPTION	数量 Qty
1	10005001	螺钉 M6×30	Screw M6×30	2
2	10059873	调节螺母 M6	Nut M6	2
3	10005078	卡圈	collar	1
4	10055048	压脚拉杆B	Connecting rod	1
5	10005139	螺钉 M5×12	Screw M5×12	2
6	10005287	弹簧固定板	Spring Board	1
7	10005233	脚杆动轴曲柄组件	Crank	1
8	10041445	脚杆动轴拉簧	Spring	1
9	10005318	螺钉 M6×8	Screw M6×8	1
10	10006434	脚杆动轴组件	Moving axis assm	1
11	10005345	卡圈	Collar	1
12	10004983	销 5×14	Pin 5×14	1

10. 机臂零件(4)

Arm parts (4)

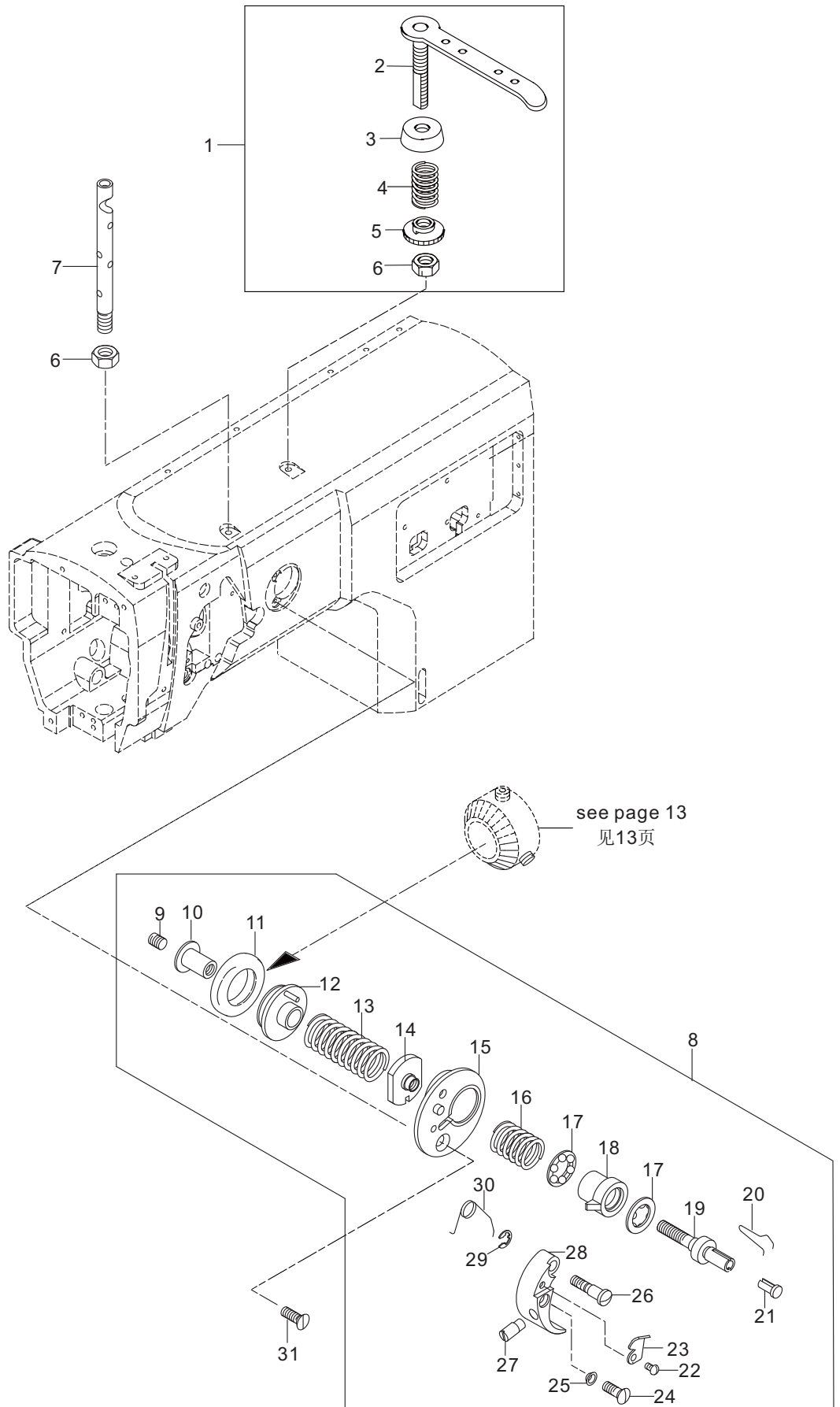

10. 机臂零件 (4)

Arm parts (4)

序号 No.	件号 Part No.	名称	DESCRIPTION	数量 Qty
1	10005108	过线器	Thread guide	1
2	10004976	过线杆组件	Thread crossing column assy	1
3	10005359	调节簧座	Thred tension disk	1
4	10005069	过线器压簧	Spring	1
5	10005520	夹线调节螺母 M6	Nut M6	1
6	10004970	六角螺母 M6	Nut M6	2
7	10005384	过线柱	Thread crossing column	1
8	10005149	绕线器	Bobbin winder unit	1
9	10012162	螺钉 M5×5	Screw M5×5	1
10	10004954	螺杆座	Screw plate	1
11	10005545	橡胶轮	Ring	1
12	10005261	绕线轮座组件	Bobbin winder shaft compl.	1
13	10005404	下压簧	Compression spring	1
14	10005075	压簧座	Compression spring seat	1
15	10005120	线圈板组件	Retaining ring assy	1
16	10005516	上压簧	Compressing spring	1
17	10005324	端面轴承	Edge bearing	2
18	10005235	芯轴衬套	Shaft bush	1
19	10005110	芯轴	Shaft	1
20	10005319	梭芯簧	Shuttle spring	1
21	10004986	梭芯衬套	Shuttle bush	1
22	10008017	切刀定位螺钉	Screw	1
23	10008016	剪刀	Knife	1
24	10005355	挡块销紧定螺钉 M3×8	Screw M3×3	1
25	10005313	挡块螺钉垫	Washer	1
26	10005033	转动螺钉 M4×4	Screw M4×4	1
27	10005553	挡块销	Pin	1
28	10005475	挡块	Plate	1
29	10003248	挡圈 Φ3	Collar	1
30	10005375	扭簧	Spring	1
31	10005459	螺钉 M4×8	Screw M4×8	1

11. 底板零件(1)

Bedplate psrts (1)

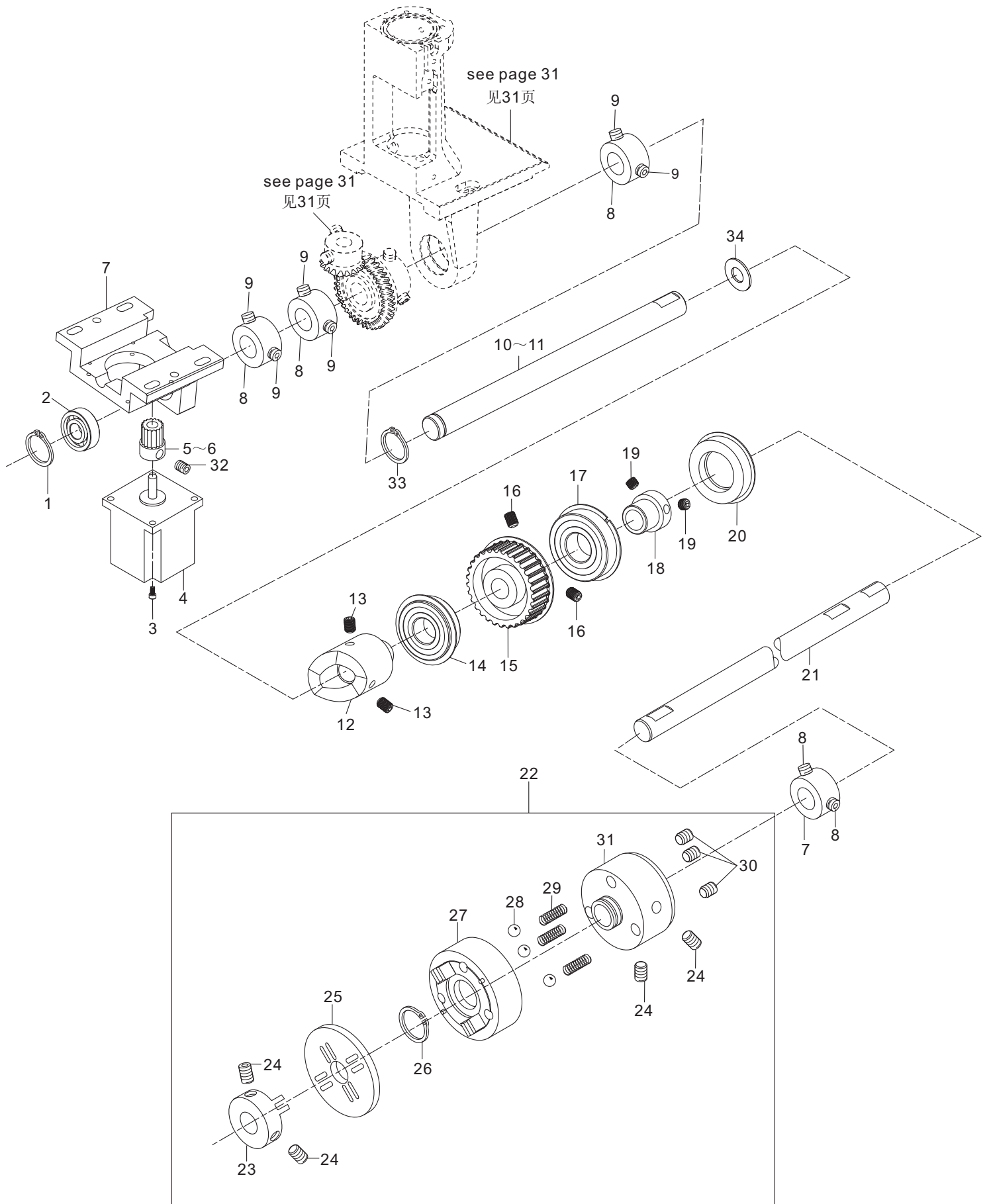

11. 底板零件 (1)

Bedplate parts (1)

序号 No.	件号 Part No.	名称	DESCRIPTION	数量 Qty
1	10005029	卡圈	Collar	1
2	10007200	轴承	Bearing	1
3	10005139	螺钉 M5×12	Screw M5×12	4
4	10062956	送料步进电机	Feeding stepping motor	1
5	10054591	送料带轮 (for 9630)	Feeding belt wheel (for 9630)	1
6	10054590	送料带轮 (for 9640)	Feeding belt wheel (for 9640)	1
7	10057356	下送料电机座	Below feeding motor support	1
8	10005409	12万向联接轴挡圈	Shaft collar	4
9	10012162	螺钉 M5×5	Screw M5×5	8
10	10038490	万向联接轴A (for 9630)	Universal coupling spindle A (for 9630)	1
11	10042082	双针万向联接轴 (for 9640)	Universal coupling spindle (for 9640)	1
12	10001509	下轴剪线凸轮	Thread trimming cam	1
13	10004938	螺钉 M6×0.75×8	Screw M6×0.75×8	2
14	10009787	轴承	Bearing	1
15	10041637	下轴宽带轮	Lower shaft sprocket	1
16	10009187	螺钉 M6×8	Screw M6×8	2
17	10007152	轴承	Bearing	1
18	20000511	下轴轴承套组件	Lower shaft rear bush	1
19	10005549	螺钉 M6×5	Screw M6×5	2
20	10041424	下轴胶塞	Rubber plug	1
21	10041426	一体下轴	Lower shaft	1
22	10005250	离合器	Clutch	1
23	10004969	离合器小连接组件	Clutch minor connector	1
24	10005300	螺钉 M6×0.75×8	Screw M6×0.75×8	4
25	10005364	离合器连接板	Clutch gusset	1
26	10005147	卡圈	Collar	1
27	10005189	离合器连接组件	Clutch connector	1
28	10013306	钢珠球	Steel ball	3
29	10004948	离合器小弹簧	Spring	3
30	10005119	螺钉 M6×0.75×6	Screw M6×0.75×6	3
31	10005486	离合器连接座	Clutch coupling	2
32	10011803	螺钉 M5×6	Screw M5×6	2
33	1005345	挡圈	Collar	1
34	10012782	垫圈	Washer	1

12. 底板零件(2)

Bedplate psrts (2)

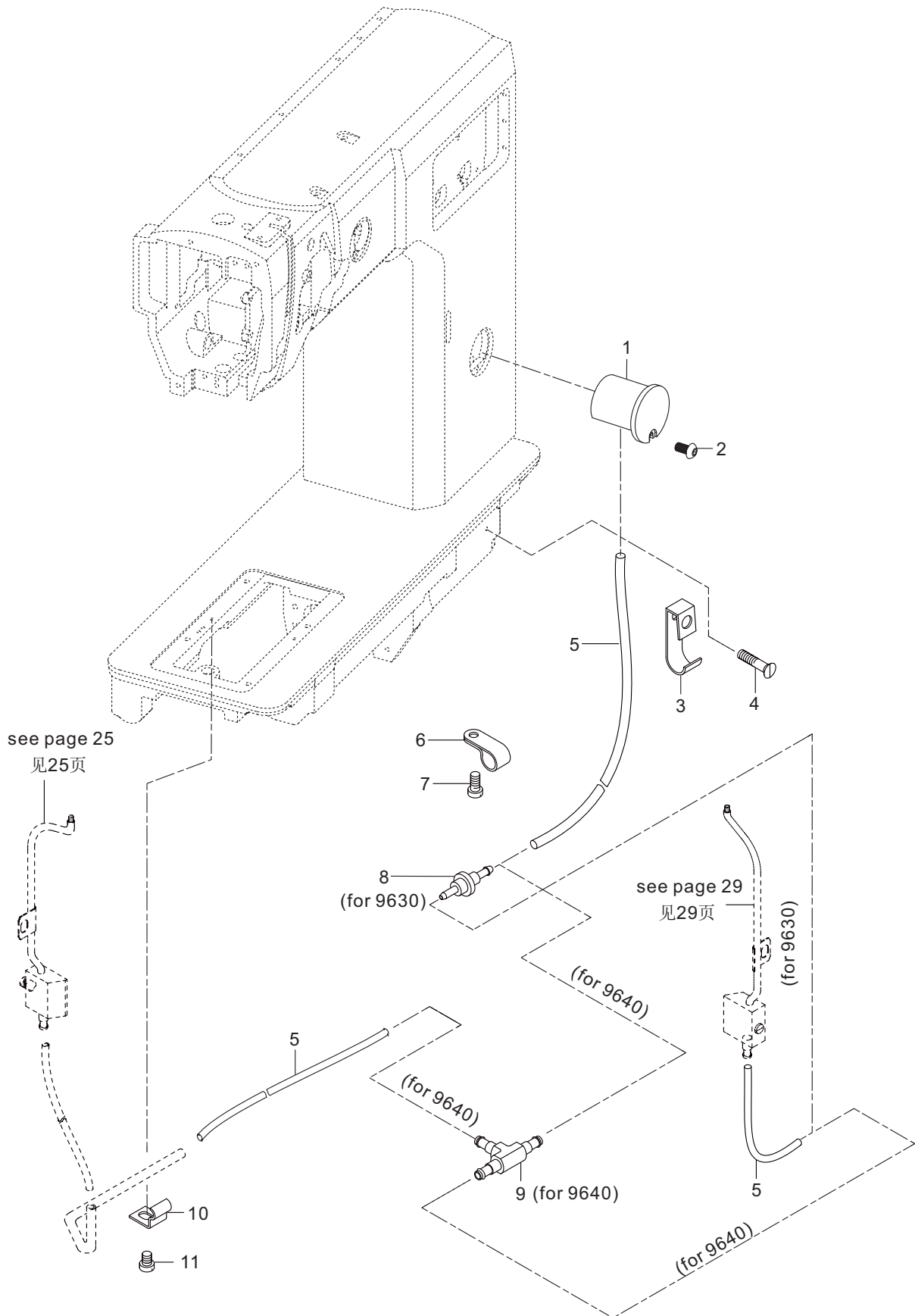

12. 底板零件 (2)

Bedplate parts (2)

序号 No.	件号 Part No.	名称	DESCRIPTION	数量 Qty
1	10041464	油窗组件	Oil tank assy	1
2	10005107	螺钉 M4×6	Screw M4×6	1
3	10004973	油管夹	Oil pipe clip	1
4	10041018	沉头螺钉 M4×14	Screw M4×14	1
5	10007800	油管	Oil tube	2
6	10008228	油管夹	Oil pipe clip	1
7	10005513	螺钉 M4×8	Screw M4×8	1
8	10005311	油管接头	Terminall	1
9	10001535	T形接头	Terminall	1
10	10002150	油管夹板	Oil tube support	1
11	10005076	螺钉 M4×5	Screw M4×5	1

13. 旋梭左支座(1) Hook post, left(1)

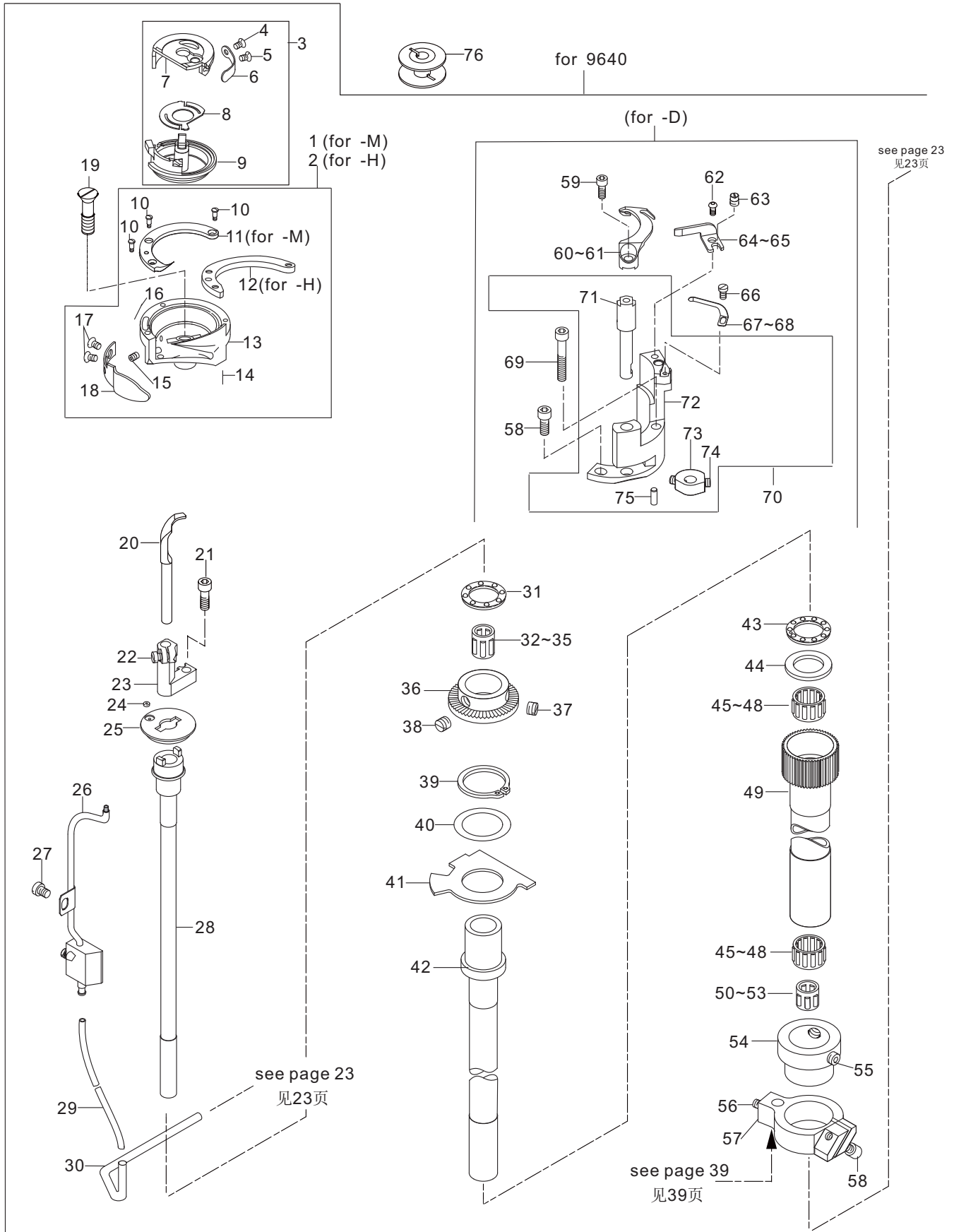

13. 旋梭左支座 (1)

Hook post, left (1)

序号 No.	件号 Part No.	名称	DESCRIPTION	数量 Qty
1	10005378	薄料旋梭 (for -M)	Hook-thin (for -M)	1
2	10004081	厚料旋梭 (for -H)	Hook-thickness (for -H)	1
3	10005393	梭壳组件	Bobbin case asm	1
4	10004944	板式弹簧螺钉 I	Screw	1
5	10005206	板式弹簧螺钉 II	Screw	1
6	10005488	板式弹簧	Spring plate	1
7	10005555	梭头体	Hook-top	1
8	10005066	弹簧片	Spring	1
9	10005518	梭兜	Shuttle wan	1
10	10005541	螺钉	Screw	3
11	10005203	内梭头舌-薄料 (for -M)	Shuttle' tongue (for -M)	1
12	10005308	内梭头舌-厚料 (for -H)	Shuttle' tongue (for -H)	1
13	10005452	梭壳	Bobbin case	1
14	10005184	注塞	Wick	1
15	10005353	油毡注塞	Oil felt wick	1
16	10005354	螺钉 M3×4	Screw M3×4	1
17	10005106	螺钉 M2.6×4	M2.6×4	2
18	10005315	护针板	Needle protected plate	1
19	10004984	螺钉 M5×13	Screw M5×20	1
20	10005182	旋梭定位勾	Positioning finger	1
21	10005366	螺钉 M4×12	Screw M4×12	1
22	10005204	螺钉 M4×6	Screw M4×6	1
23	10005154	旋梭定位勾座	Positioning finger plate	1
24	10004937	O形圈	O ring	1
25	10005360	旋梭端盖	hook lid	1
26	10005394	油量调节组成	Rubber assy	1
27	10005076	螺钉 M4×5	Screw M4×5	1
28	10005245	旋梭传动芯轴	Hook transmission mandrel	1
29	10007800	油管	Oil felt	1
30	10002151	铜油管	Copper tubing	1
31	10005346	小端面轴承	Small end bearing	1
32	10007373	滚针轴承	Needle bearing	(1)
33	10007404	滚针轴承	Needle bearing	(1)
34	10007405	滚针轴承	Needle bearing	(1)
35	10007374	滚针轴承	Needle bearing	1
36	10001555	送料转盘	Feeding wheel	1
37	10001538	送料转盘螺钉 I M6×0.75×3	Screw M6×0.75×3	1
38	10001559	送料转盘螺钉 M6×.075×5	Screw M6×0.75×3	1
39	10001416	20旋梭护片卡圈	Collar	1
40	10001415	20旋梭护片垫圈	Collar	1
41	10001611	旋梭护片	Armor pieces	1
42	10001558	574送料传动轴	574 feeding drive shaft	1
43	10001556	574端面轴承	574 end bearing	1
44	10001560	端面轴承垫圈	Washer	1
45	10007759	滚针轴承	Needle bearing	2
46	10007758	滚针轴承	Needle bearing	(2)
47	10007757	滚针轴承	Needle bearing	(2)
48	10008054	滚针轴承	Needle bearing	(2)
49	10008234	574旋梭传动轴 I	574 hook shaft	1
50	10007368	滚针轴承	Needle bearing	(1)
51	10007367	滚针轴承	Needle bearing	1
52	10007199	滚针轴承	Needle bearing	1
53	10007198	滚针轴承	Needle bearing	1
54	10001887	20旋梭传动轴挡圈	Retaining ring	1
55	10005549	螺钉 M6×0.75×5	Screw M6×0.75×5	2
56	10012162	螺钉 M5×5	Screw M5×5	1
57	10001426	574旋梭传动曲柄	Crank	1
58	10012752	螺钉 M4×10	Screw M4×10	2
59	10005692	螺钉 M4×10	Screw M4×10	1
60	10039485	动刀 (台湾)	Movable knife (Made in Taiwan)	1
61	10038408	动刀 (国产)	Movable knife (Made in Chian)	(1)
62	10005107	螺钉 M4×6	Screw M4×6	1
63	10038411	偏心销	Eccentric pin	1
64	10039486	定刀 (台湾)	Fixed knife (Made in Taiwan)	1
65	10038410	定刀 (国产)	Fixed knife (Made in Chian)	1
66	10001512	螺钉 M2.5×3	Screw M2.5×3	1
67	10039487	线夹 (台湾)	Wire clip (Made in Taiwan)	1
68	10038412	线夹 (国产)	Wire clip (Made in Chian)	(1)
69	10001608	螺钉 M4×25	Screw M4×25	1
70	10038405	定刀支架部件	Moveble knife lever	1
71	10038407	勾线板支架A	Knife holder	1
72	10038406	定刀支架	Fixed knife bracket seat	1
73	10001517	传动齿轮	Transmission gear	1
74	10001514	螺钉 M4×4	Screw M4×4	2
75	10002069	定位销 3×10	Pin 3×10	1
76	10005461	梭心	Bobbin	1

14. 旋梭左支座(2) Hook post, left(2)

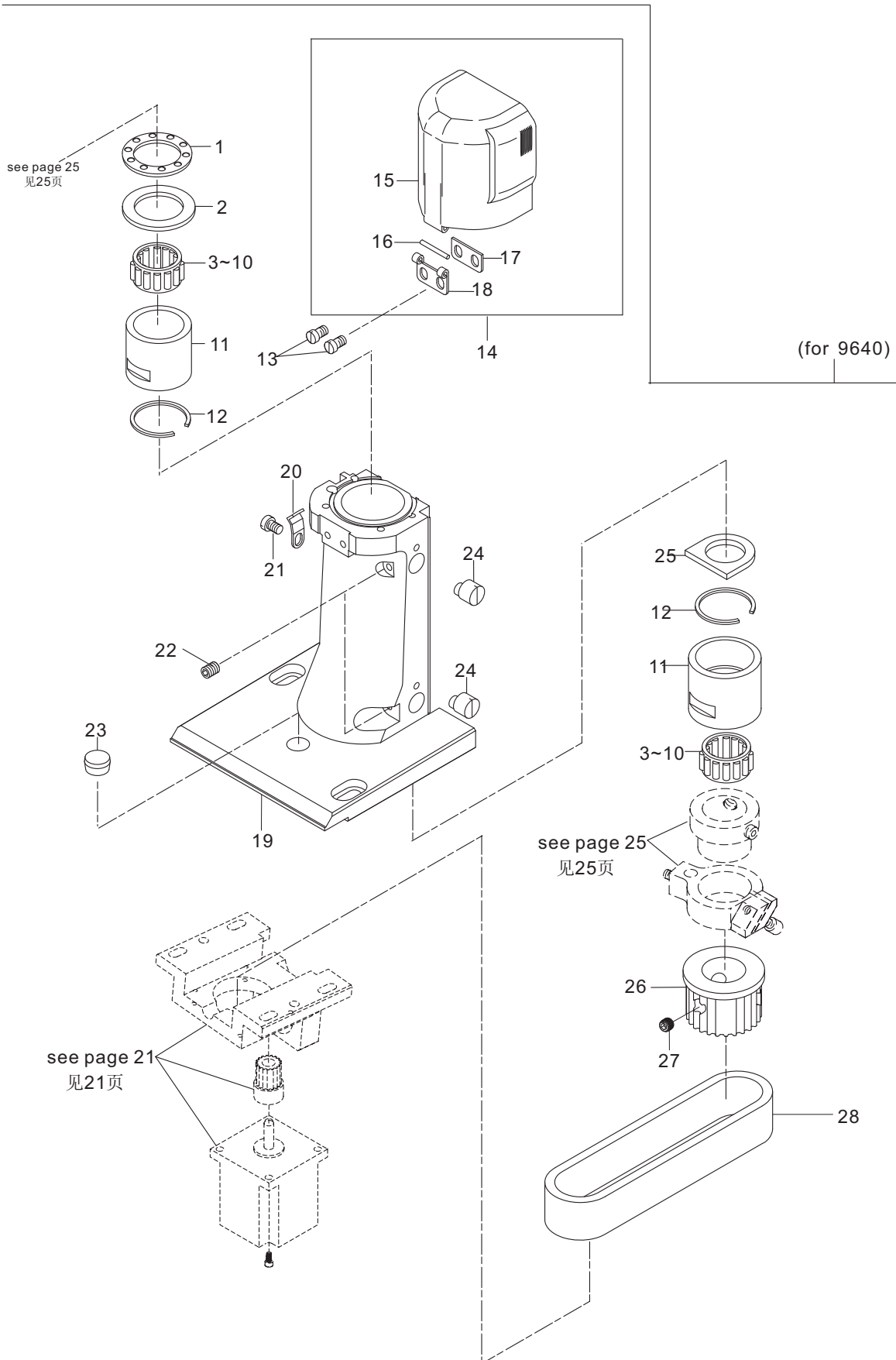

14. 旋梭左支座 (2)

Hook post, left (2)

序号 No.	件号 Part No.	名称	DESCRIPTION	数量 Qty
1	10005398	端面轴承	End bearing	1
2	10005052	垫圈	Washer	1
3	10005450	滚针轴承	Needle bearing	2
4	10006931	滚针轴承	Needle bearing	(2)
5	10006932	滚针轴承	Needle bearing	(2)
6	10006933	滚针轴承	Needle bearing	(2)
7	10007377	滚针轴承	Needle bearing	(2)
8	10007376	滚针轴承	Needle bearing	(2)
9	10007275	滚针轴承	Needle bearing	(2)
10	10007274	滚针轴承	Needle bearing	(2)
11	10005259	旋梭传动轴轴套	Hook shaft sleeve	2
12	10005383	挡圈	Collar	2
13	10005186	螺钉 M4×8	Screw M4×8	2
14	10038399	旋梭防护罩组件	Hook shield components	1
15	10038400	旋梭防护罩	Hook shield	1
16	10038404	销	Pin	1
17	10038403	垫片	Washer	1
18	10038402	护罩转动座	Shield driving seat	1
19	10057378	旋梭左支座E	Hook the left bearing	1
20	10004999	弹簧板	Spring plate	1
21	10005309	螺钉 M4×6	Screw M4×6	1
22	10009741	螺钉 M4×6	Screw M4×6	2
23	10005407	油塞	Oil plug	1
24	10005215	偏心销	Eccentric pin	2
25	10005177	油毡	Oil felt	1
26	10057352	双针电机带轮	Belt wheel	1
27	10057353	带轮螺钉M6×0.75	Screw M6×0.75	3
28	10057355	S3M同步带C	S3M Belt C	1

15. 旋梭右支座(1) Hook post, right(1)

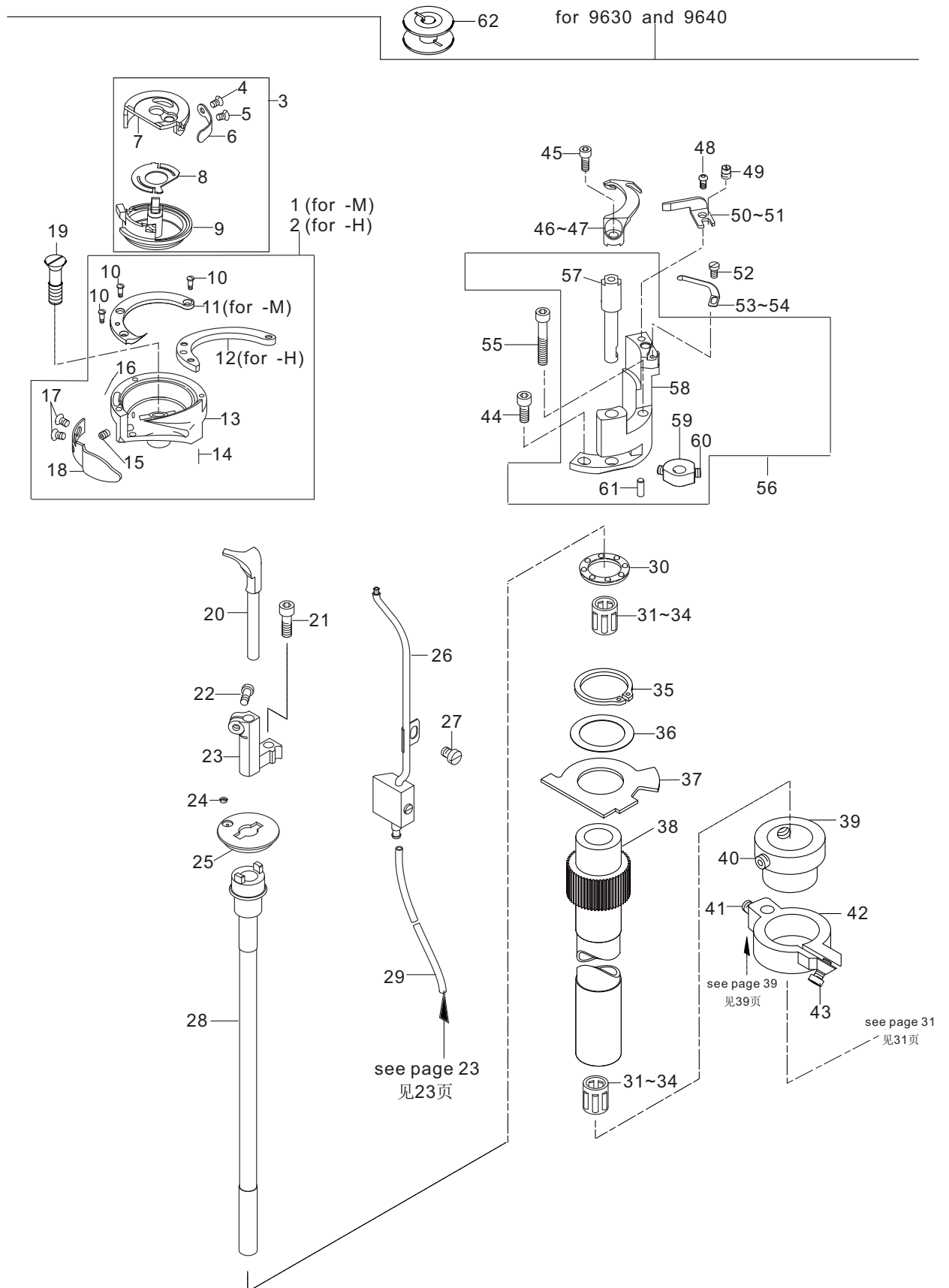

15. 旋梭右支座 (1)

Hook post, right (1)

序号 No.	件号 Part No.	名称	DESCRIPTION	数量 Qty
1	10005378	薄料旋梭 (for -M)	Hook-thin (for -M)	1
2	10004081	厚料旋梭 (for -H)	Hook-thickness (for -H)	1
3	10005393	梭壳组件	Bobbin case asm	1
4	10004944	板式弹簧螺钉 I	Screw	1
5	10005206	板式弹簧螺钉 II	Screw	1
6	10005488	板式弹簧	Spring plate	1
7	10005555	梭头体	Hook-top	1
8	10005066	弹簧片	Spring	1
9	10005518	梭宛	Shuttle wan	1
10	10005541	螺钉	Screw	3
11	10005203	内梭头舌-薄料 (for -M)	Shuttle' tongue (for -M)	1
12	10005308	内梭头舌-厚料 (for -H)	Shuttle' tongue (for -H)	1
13	10005452	梭壳	Bobbin case	1
14	10005184	注塞	Wick	1
15	10005353	油毡注塞	Oil felt wick	1
16	10005354	螺钉 M3×4	Screw M3×4	1
17	10005106	螺钉 M2.6×4	M2.6×4	1
18	10005315	护针板	Needle protected plate	1
19	10056815	螺钉 M5×13	Screw M5×20	1
20	10005182	旋梭定位勾	Positioning finger	1
21	10005366	螺钉 M4×12	Screw M4×12	1
22	10005204	螺钉 M4×6	Screw M4×6	1
23	10005154	旋梭定位勾座	Positioning finger plate	1
24	10004937	O形圈	O ring	1
25	10005360	旋梭端盖	hook lid	1
26	10005394	油量调节组成	Rubber assy	1
27	10005076	螺钉 M4×5	Screw M4×5	1
28	10005245	旋梭传动芯轴	Hook transmission mandrel	1
29	10007800	油管	Oil felt	1
30	10005346	小端面轴承	End bearing	1
31	10007374	滚针轴承	Needle bearing	(2)
32	10007405	滚针轴承	Needle bearing	(2)
33	10007404	滚针轴承	Needle bearing	2
34	10007373	滚针轴承	Needle bearing	(2)
35	10003346	轴用挡圈	Collar	1
36	10001415	20旋梭护片垫圈	Washer	1
37	10001611	旋梭护片	Armor pieces	1
38	10001418	旋梭传动轴	hook shaft	1
39	10001887	20旋梭传动轴挡圈	Collar	1
40	10005549	螺钉 M6×0.75×5	Screw M6×0.75×5	2
41	10012162	螺钉 M5×5	Screw M5×5	1
42	10002106	旋梭传动曲柄	Crank	1
43	10012752	螺钉 M4×10	Screw M4×10	1
44	10012752	螺钉 M4×10	Screw M4×10	2
45	10005692	螺钉 M4×10	Screw M4×10	1
46	10039485	动刀 (台湾)	Movable knife (Made in Taiwan)	1
47	10038408	动刀 (国产)	Movable knife (Made in Chian)	(1)
48	10005107	螺钉 M4×6	Screw M4×6	1
49	10038411	偏心销	Eccentric pin	1
50	10039486	定刀 (台湾)	Fixed knife (Made in Taiwan)	1
51	10038410	定刀 (国产)	Fixed knife (Made in Chian)	1
52	10001512	螺钉 M2.5×3	Screw M2.5×3	1
53	10039487	线夹 (台湾)	Wire clip (Made in Taiwan)	1
54	10038412	线夹 (国产)	Wire clip (Made in Chian)	(1)
55	10001608	螺钉 M4×25	Screw M4×25	1
56	10038405	定刀支架部件	Moveble knife lever	1
57	10038407	勾线板支架A	Knife holder	1
58	10038406	定刀支架	Fixed knife bracket seat	1
59	10001517	传动齿轮	Transmission gear	1
60	10001514	螺钉 M4×4	Screw M4×4	2
61	10002069	定位销 3×10	Pin 3×10	1
62	10005461	梭心	Bobbin	1

16. 旋梭右支座(2) Hook post, right(2)

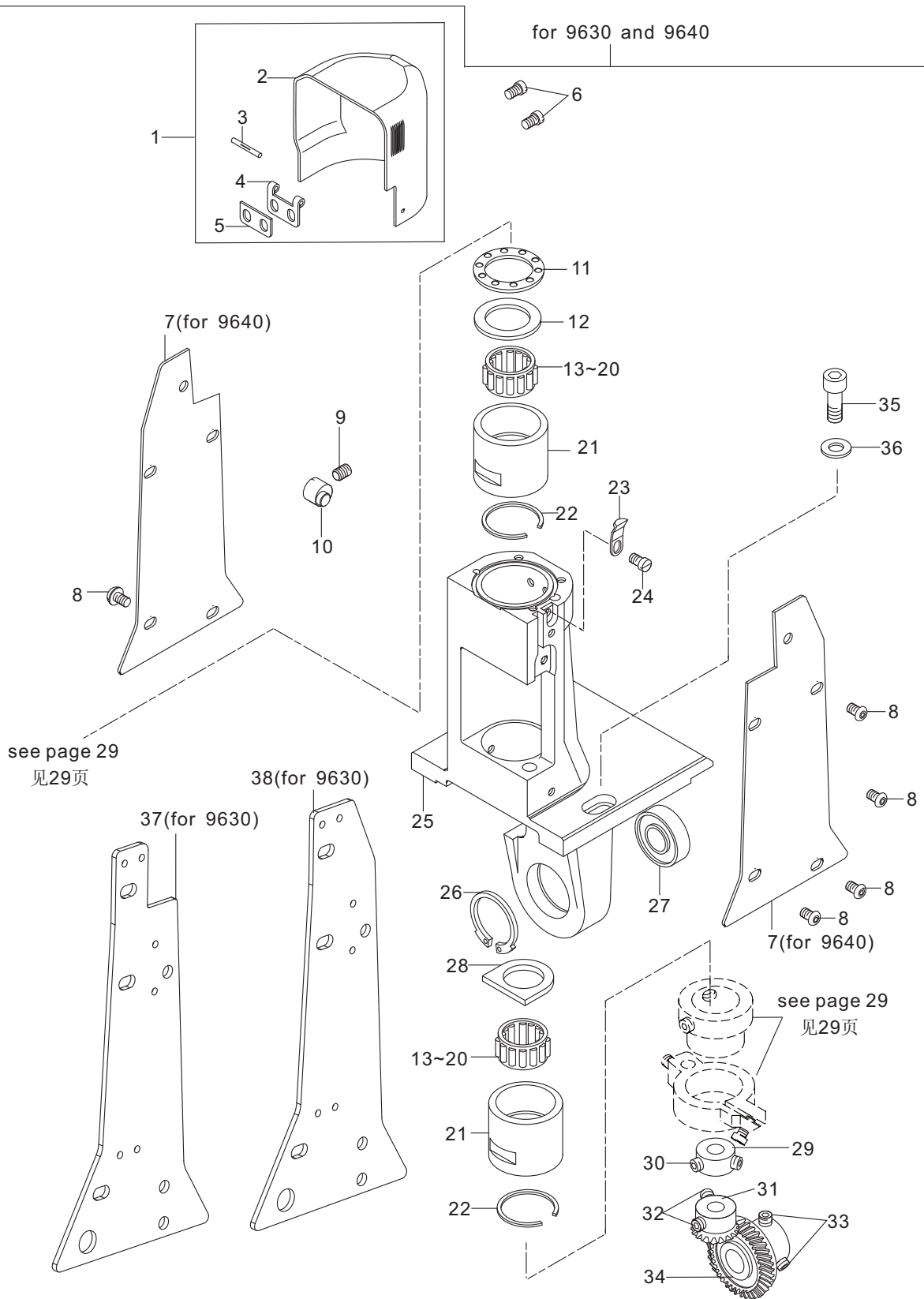

16.旋梭右支座 (2)

Hook post, right (2)

序号 No.	件号 Part No.	名称	DESCRIPTION	数量 Qty
1	10038399	旋梭防护罩组件	Hook shield components	1
2	10038400	旋梭防护罩	Hook shield	1
3	10038404	销	Pin	1
4	10038402	护罩转动座	Shield driving seat	1
5	10038403	垫片	Washer	1
6	10005186	螺钉 M4×8	Screw M4×8	2
7	20013284	双针侧盖板喷漆 (for 9640)	Double needle plate measuring (for 9640)	2
8	10005107	螺钉 M4×6	Screw M4×6	10
9	10009741	螺钉 M4×6	Screw M4×6	2
10	10005215	偏心销	Eccentric pin	2
11	10005398	端面轴承	End bearing	1
12	10005052	21垫圈	Washer	1
13	10005450	滚针轴承	Needle bearing	2
14	10006931	滚针轴承	Needle bearing	(2)
15	10006932	滚针轴承	Needle bearing	(2)
16	10006933	滚针轴承	Needle bearing	(2)
17	10007377	滚针轴承	Needle bearing	2
18	10007376	滚针轴承	Needle bearing	(2)
19	10007275	滚针轴承	Needle bearing	(2)
20	10007274	滚针轴承	Needle bearing	(2)
21	10005259	旋梭传动轴轴套	Hook shaft sleeve	2
22	10005383	挡圈	Collar	2
23	10004999	弹簧板	Spring plate	1
24	10005309	螺钉 M4×6	Screw M4×6	1
25	20003491	旋梭支座喷漆	Hook the right bearing	1
26	10005029	28挡圈	Collar	1
27	10007200	轴承 6001ZZ	Bearing 6001ZZ	1
28	10005177	油毡	Oil felt	1
29	10005413	8旋梭传动芯轴挡圈	Collar	1
30	10005549	螺钉 M6×0.75×5	Screw M6×0.75×5	2
31	10006298	旋梭传动齿轮 II	The hook driving gear II	1
32	10005258	螺钉 M6×0.75×5	Screw M6×0.75×5	2
33	10005119	螺钉 M6×0.75×6	Screw M6×0.75×6	2
34	10006297	旋梭传动齿轮 I	The hook driving gear I	1
35	10009008	螺钉 M6×16	Screw M6×16	4
36	10005550	垫圈 Φ6	Washer Φ6	4
37	20013282	单针侧盖板A喷漆 (for 9630)	One needle plate measuring (for 9630)	1
38	20003490	侧盖板I (for 9630)	Plate measuring (for 9630)	1

17. 送料支座

Feed wheel post, left

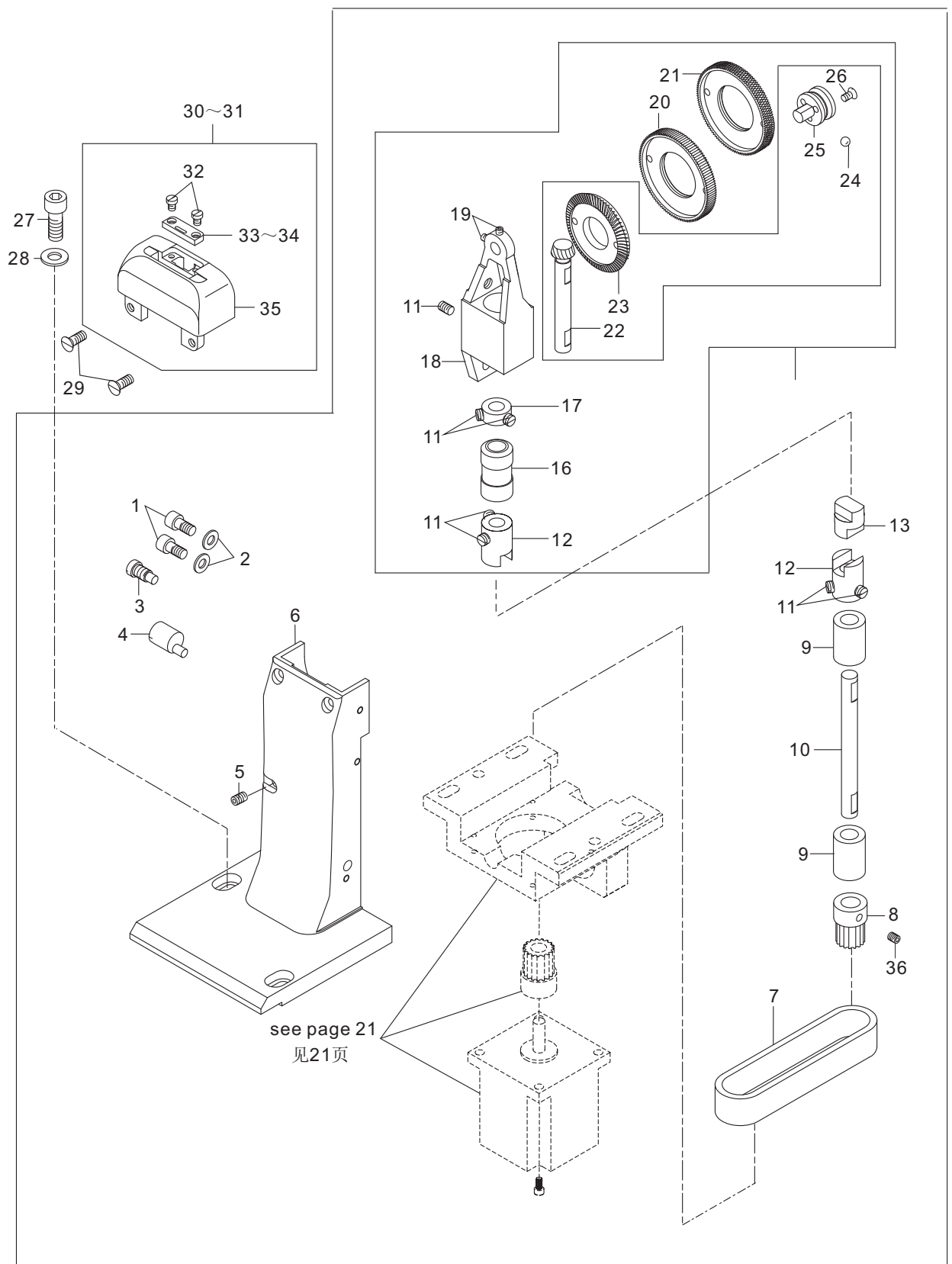

17.送料支座

Feed wheel post , left

序号 No.	件号 Part No.	名称	DESCRIPTION	数量 Qty
1	10005139	螺钉 M5×12	Screw M5×12	2
2	10005016	垫圈 Φ5	Washer Φ5	2
3	10004978	螺钉 M6×8	Screw M6×8	1
4	10005257	偏心销	Pin	1
5	10009741	螺钉 M4×6	Screw M4×6	1
6	20021226	送料支座E喷漆	Feeding support E paint	1
7	10054593	S3M传送带B	S3M Conveyor B	1
8	10054590	Φ7电机带轮	Belt wheel Φ7	1
9	10005431	套	Axle sleeve	2
10	10005402	送料传动轴	Feeding transmission shaft	1
11	10012162	螺钉 M5×5	Screw M5×5	7
12	10005236	联接衬套	Coupling bushing	2
13	10005084	联接块	Connecting block	1
14	10005376	送料机构组件（直齿送料轮）	Straight tooth feeding mechanism	1
15	10043255	滚花送料机构组件（滚花送料轮）	Knurling tooth feeding mechanism	(1)
16	10005082	送料机构座前轴套	Axle sleeve	1
17	10005310	送料传动锥齿轮挡圈	Collar	1
18	10005185	送料机构座	Feeding mechanism of bearing	1
19	10005354	螺钉 M3×4	Screw M3×4	2
20	10005037	送料盘（直齿送料轮）	Feeding straight tooth	1
21	10043256	滚花送料盘（滚花送料轮）	Knurling tooth feed tray	(1)
22	10005071	送料传动锥齿轮 I	The feed driving bevel gear I	1
23	10005117	送料传动锥齿轮 II	The feed driving bevel gear II	1
24	10006178	钢球 Φ2	Steel ball Φ2	23
25	10028364	送料齿联接块组件	The Connecting block assembly	1
26	10005348	螺钉 M2.5×4	Screw M2.5×4	3
27	10009008	螺钉 M6×16	Screw M6×16	2
28	10003324	垫圈 Φ6	Washer Φ6	2
29	10005459	螺钉 M4×8	Screw M4×8	2
30	10055259	单针针板组件（-M）	Single needle plate assembly（-M）	1
31	10055260	单针针板组件（-H）	Single needle plate assembly（-H）	(1)
32	10003903	针板螺钉 M2×3	Screw M2×3	2
33	10055257	小针板-薄料（for -M）	Small needle plate -thin material（for -M）	1
34	10055258	小针板-厚料（for -H）	Small needle plate -thick material（for -H）	(1)
35	10053427	针板罩S	Needle plate seat S	1
36	10011803	螺钉 M5×6	Screw M5×6	2

18. 送料轮托盘

Feed wheel mounting plate

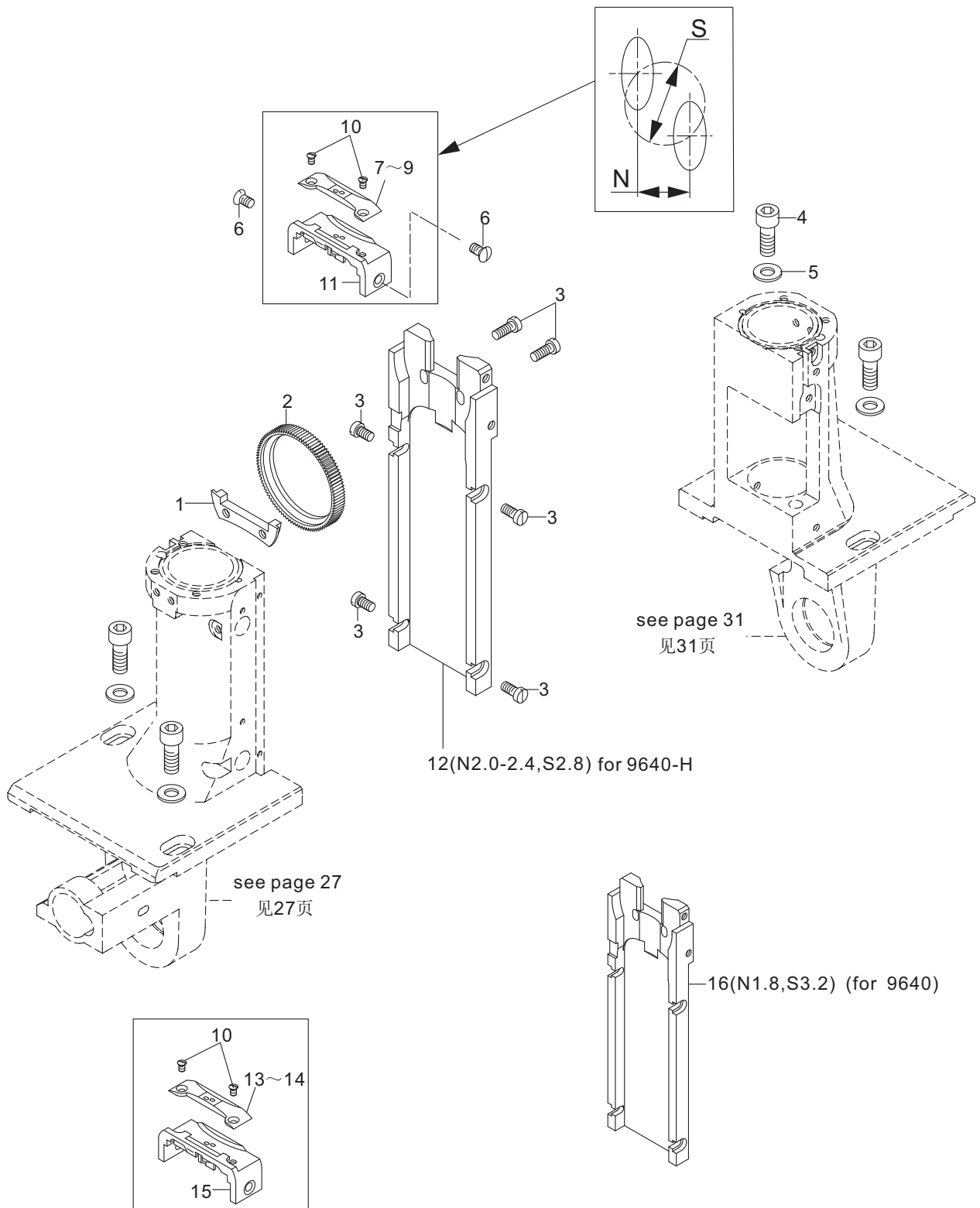

18.送料轮托盘

Feed wheel mounting plate

序号 No.	件号 Part No.	名称	DESCRIPTION	数量 Qty
1	10030181	送料轮调整块	Feeding wheel adjusting block	1
2	10030180	送料轮	Feeding wheel	1
3	10001580	螺钉 M4×10	Screw M4×10	6
4	10009008	螺钉 M6×16	Screw M6×10	4
5	10005550	垫圈 Φ6	Washer Φ6	4
6	10002545	螺钉 M4×6	Screw M4×6	2
7	10051304	双针小针板(N1.2-1.8,S2.8)	Small double needle plate(N1.2-1.8)	1
8	10051305	双针小针板(N2.0-2.4,S2.8)	Small double needle plate(N2.0-2.4)	(1)
9	10060561	双针小针板(N2.2-2.6,S2.8)	Small double needle plate(N2.0-2.6)	(1)
10	10049413	双针针板固定螺钉 M3×3.2	Screw M3×3.2	2
11	10051303	针板罩(N2.0-2.4,S2.8)	Double needle plate cover(N2.0-2.4)	1
12	10043208	针板罩座(N2.0-2.4,S2.8)	Double needle plate cover seat(N2.0-2.4)	1
13	10001383	双针小针板(N1.8,S3.2) for -M	Small double needle plate(N1.8)	(1)
14	10030579	双针小针板(N1.8,S3.2) for -H	Small double needle plate(N1.8)	(1)
15	10041325	针板罩 (N1.8,S3.2)	Double needle plate cover(N1.8)	(1)
16	10001388	针板罩座 (N1.8,S3.2)	Double needle plate cover seat (N1.8)	(1)

19. 剪线结构(-D) Thread trimmer (-D)

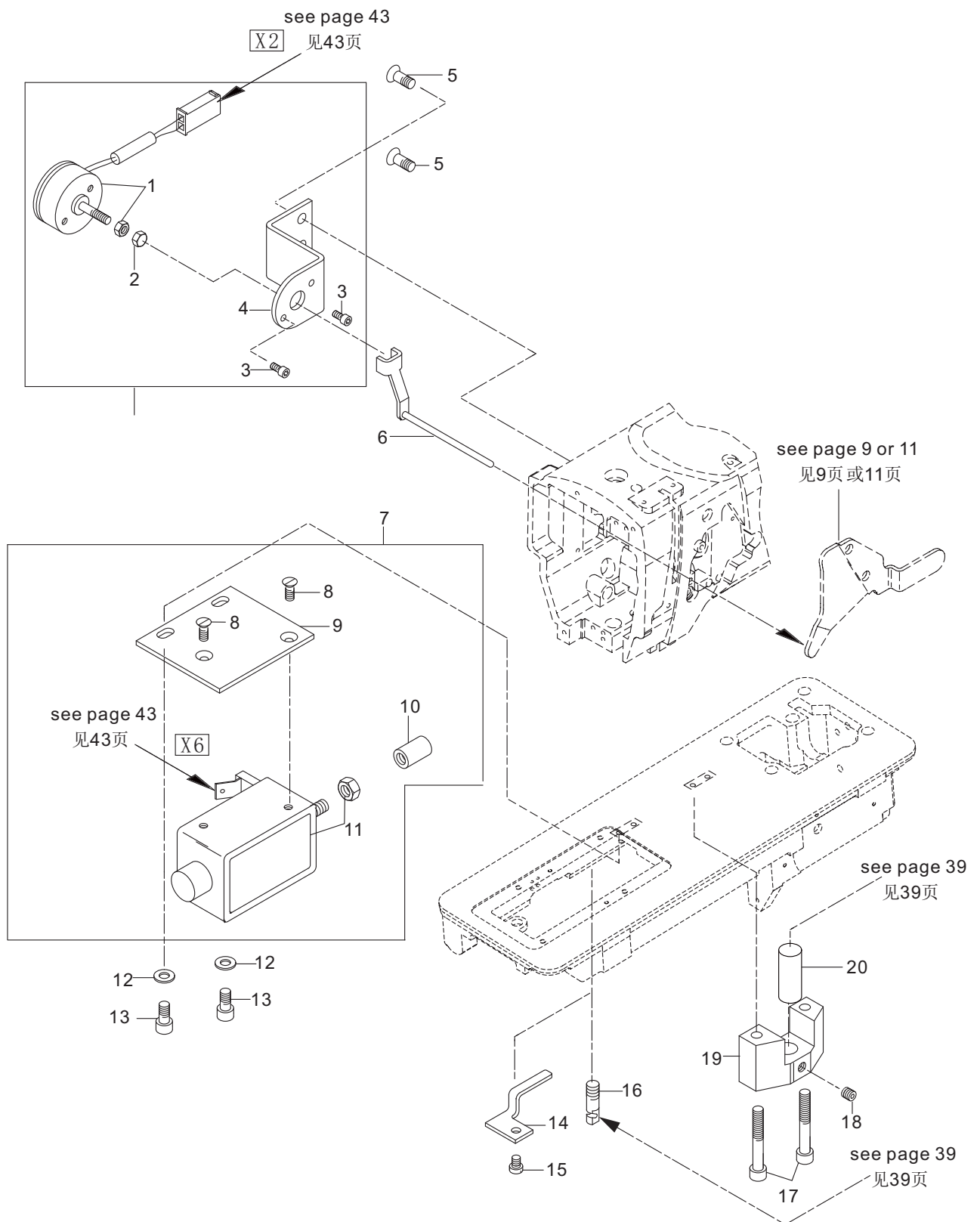

19.剪线结构 (-D)

Thread trimmer (-D)

序号 No.	件号 Part No.	名称	DESCRIPTION	数量 Qty
1	10001510	松线电磁铁	Loose line electromagnet	1
2	10001511	挺线电磁铁帽 M4	Nut M4	1
3	10002129	螺钉 M3×5	Screw M3×5	2
4	10001506	松线电磁铁安装板	Mounting plate	1
5	10001948	螺钉 M5×10	Screw M5×10	2
6	10001657	电磁铁挺线钉	Tension release pin	1
7	10006402	剪线电磁铁整组	Shear line electromagnet assembly	1
8	10008233	螺钉 M4×6	Screw M4×6	2
9	10001502	剪线电磁铁安装板	Mounting plate	1
10	10001614	剪线电磁铁联接节	Connecting block	1
11	10001499	剪线电磁铁	Shear line electromagnet	1
12	10005016	垫圈 Φ5	Washer Φ5	2
13	10010953	螺钉 M5×10	Screw M5×10	2
14	10001508	油线挡板	Oil line baffle	1
15	10005076	螺钉 M4×5	Screw M4×5	1
16	10005318	螺钉 M6×8	Screw M6×8	1
17	10001497	螺钉 M5×30	Screw M5×30	2
18	10012162	螺钉 M5×5	Screw M5×5	1
19	10002142	剪线摆动杆座	Shear line swing rod seat	1
20	10001498	剪线摆动杆座销 10×32	Pin 10×32	1

20. 剪线结构(-D) Thread trimmer (-D)

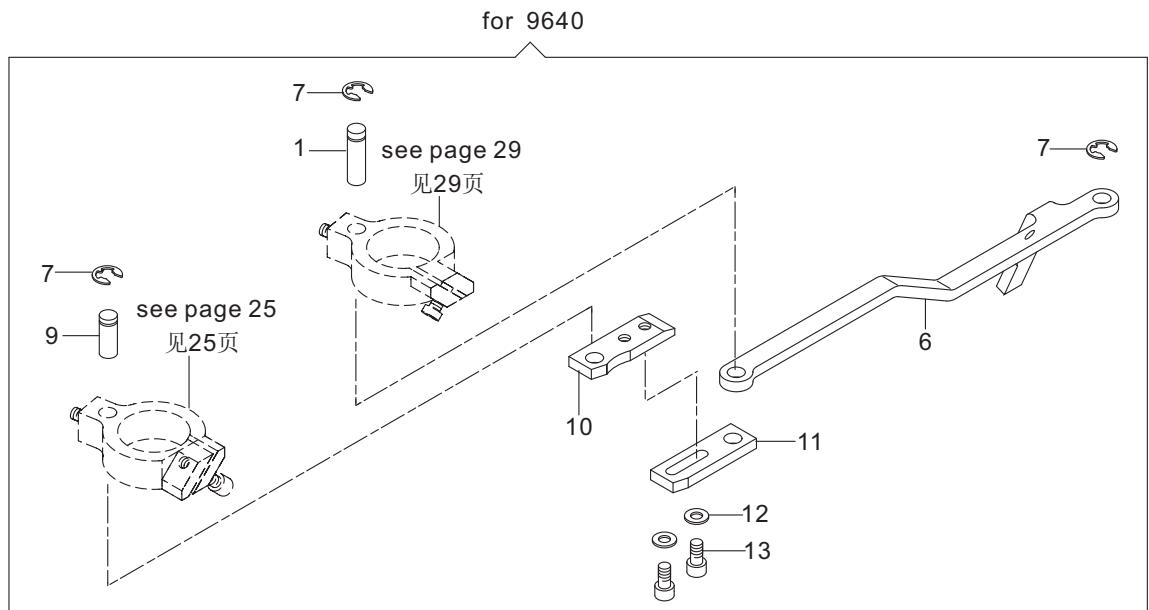
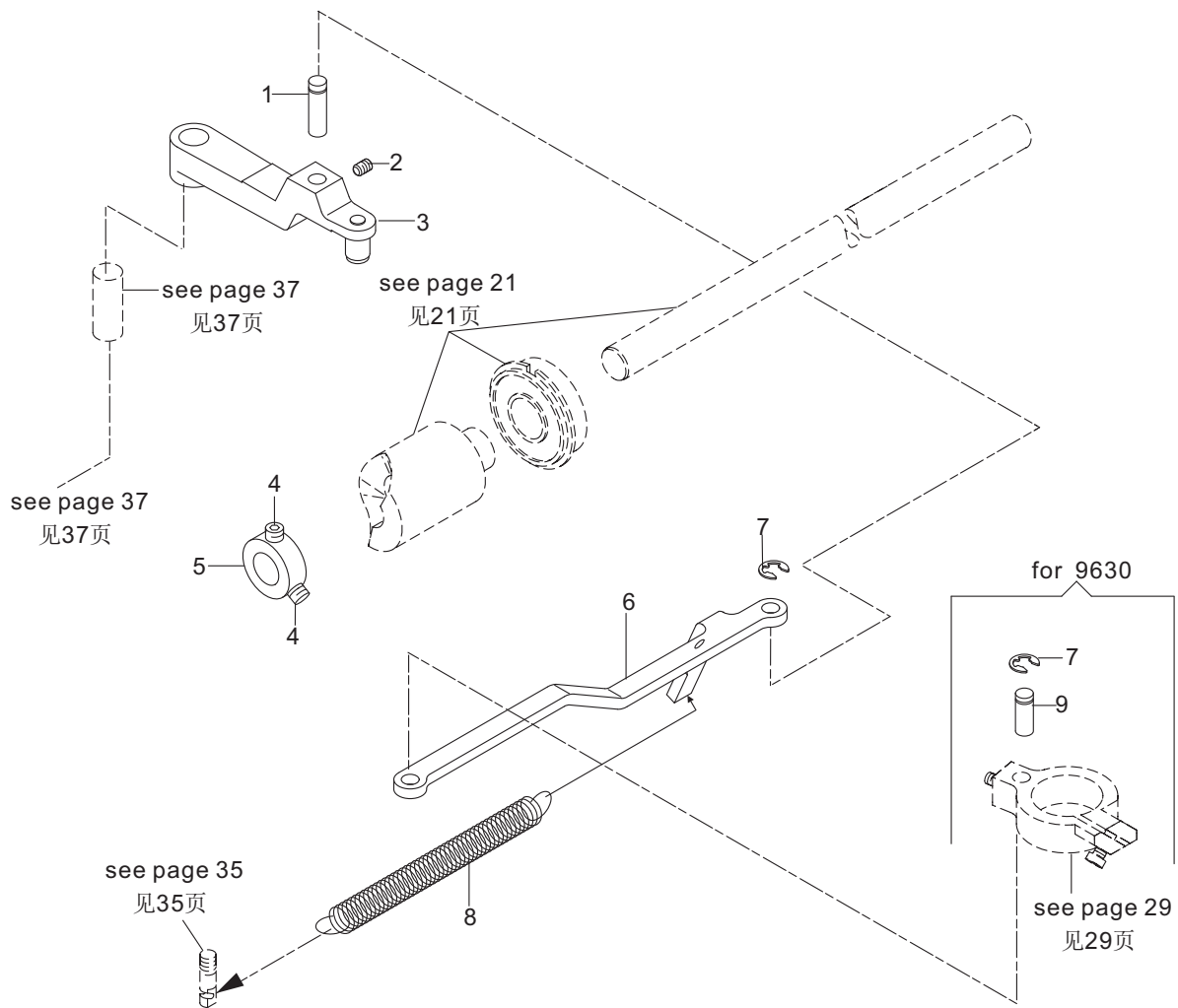

20.剪线结构 (-D)

Thread trimmer (-D)

序号 No.	件号 Part No.	名称	DESCRIPTION	数量 Qty
1	10001501	剪线摆动杆销	Pin	2
2	10012162	螺钉 M5×5	Screw M5×5	1
3	10001503	剪线摆动杆组件	Swing rod assembly	1
4	10012162	螺钉 M5×5	Screw M5×5	2
5	10005409	12万向联接轴挡圈	Retaining ring	1
6	10001504	剪线摆动拉杆	Shear line swing rod	1
7	10001947	剪线摆动杆销卡圈	Collar	3
8	10001946	剪线摆动拉杆弹簧	Spring	1
9	10001505	剪线摆动销	Pin	2
10	10002201	剪线摆动拉杆连接板 II	Connecting plate II	1
11	10001722	剪线摆动拉杆连接板 I	Connecting plate I	1
12	10005260	垫圈 Φ4	Washer Φ4	2
13	10005350	螺钉 M4×8	Screw M4×8	2

21. 自动抬压脚

Automatic presser foot lifter

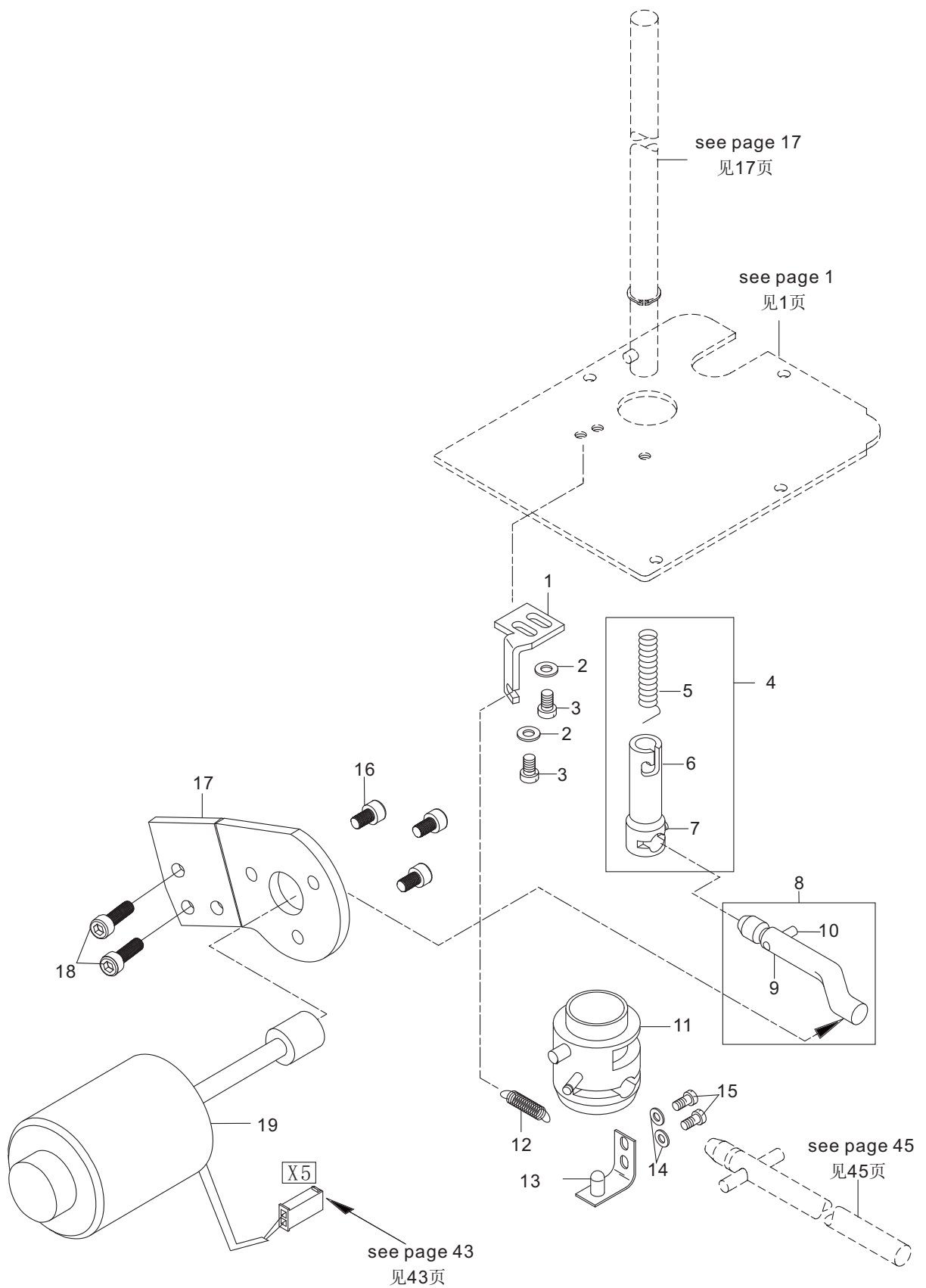

21.自动抬压脚 Automation presser foot lifter

序号 No.	件号 Part No.	名称	DESCRIPTION	数量 Qty
1	10001489	操纵顶柱复位板	Reset plate	1
2	10005260	垫圈 Φ4	Washer Φ4	2
3	10010953	螺钉 M5×10	Screw M5×10	2
4	10005514	操纵顶柱组件	Manipulating the top column assembly	1
5	10005158	操纵顶柱弹簧	Spring	1
6	10005053	操纵顶柱	Manipulating of the top pillar	1
7	10009741	螺钉 M4×6	Screw M4×6	1
8	10002145	操纵弯杆组件	Control rod bending component	1
9	10002146	操纵弯杆	Control rod bending	1
10	10001487	操作弯杆销 4×16	Pin	1
11	10001453	脚膝抬压脚操作顶柱组件	Presser foot lifting component of knee	1
12	10002144	复位弹簧	Spring	1
13	10001450	操纵弯杆挡片组件	Baffle assembly	1
14	10005260	垫圈 Φ4	Washer Φ4	2
15	10005204	螺钉 M4×6	Screw M4×6	2
16	10005122	螺钉 M6×10	Screw M6×10	3
17	10001802	中间板	Mounting plate	1
18	10002028	螺钉 M6×20	Screw M6×20	2
19	10041477	一体机压脚电磁铁	Presser foot lifting electromagnet	1

22. 电控 Electronic control

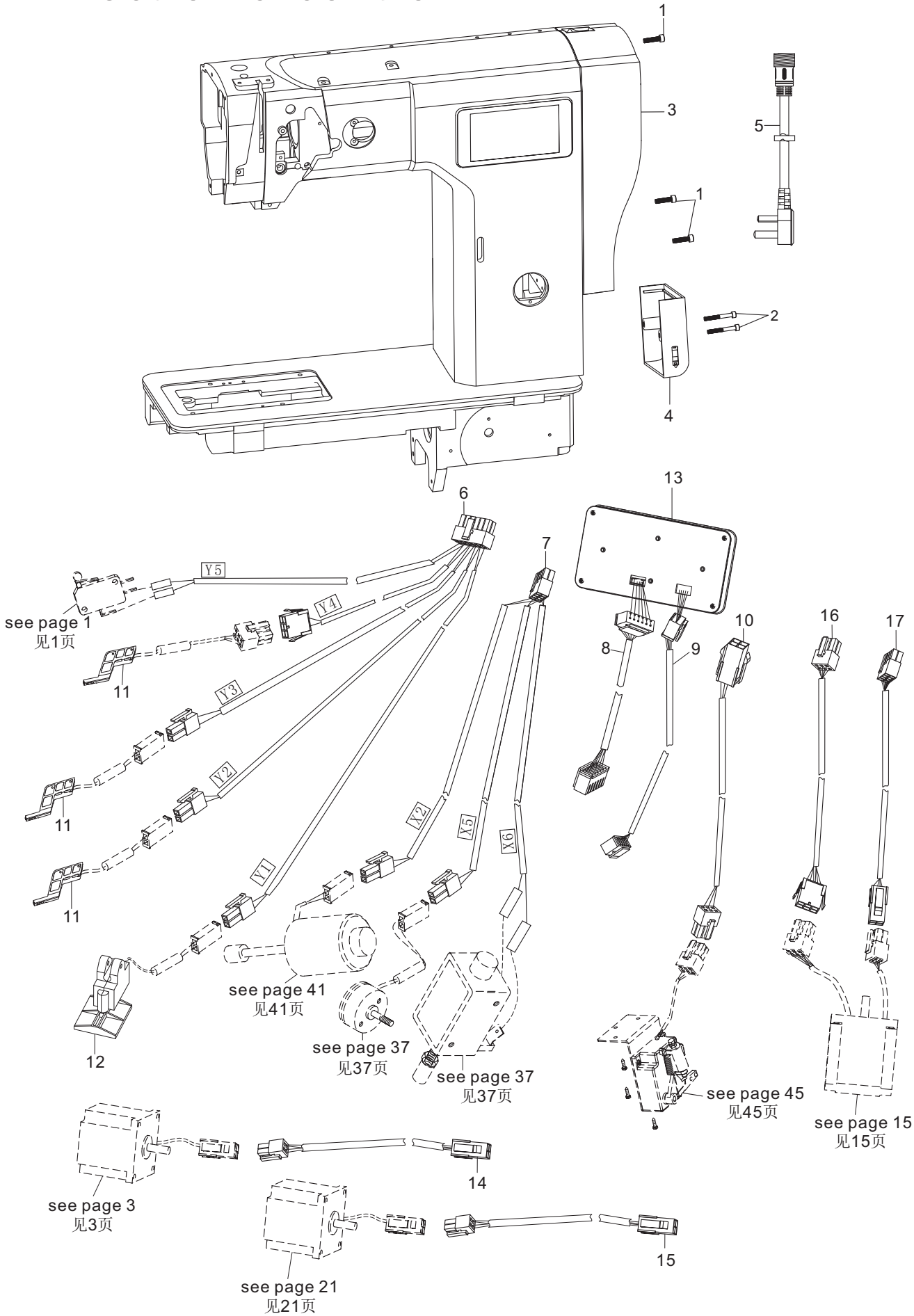

22. 电控

Electric control

序号 No.	件号 Part No.	名称	DESCRIPTION	数量 Qty
1	10003100	螺钉 M5×35	Screw M5×35	3
2	10003141	螺钉 M5×20	Screw M5×20	4
3	10061329	步进电控	Electronic control	1
4	10062455	电控下罩盖	Cover	1
5	10052822	电源转接线	The power adapter cable	1
6	10062962	机头灯转接线	Head lamp adapte	1
7	10062961	步进电磁铁线	Stepping electromagnet line	1
8	10062963	面板烧录转接线	Panel burn switch line	1
9	10062964	面板选针盒转接线	Panel needle selection box switch line	1
10	10062965	踏板转接线	Redal switch line	1
11	10061239	机头灯组件	Head lamp subassembly	1
12	20022622	点动膝控组件	Inching switch by keen	1
13	10063214	液晶面板	LCD panel	1
14	10062957	上送料步进转接线	Upper feeding stepping motor switch line	1
15	10062958	下送料步进转接线	Nether feeding stepping motor switch line	1
16	10062960	摆针步进编码器线	Stepping motor encoder line	1
17	10062959	摆针步进转接线	Stepping motor switch line	1

23. 附件(1)

Accessories components (1)

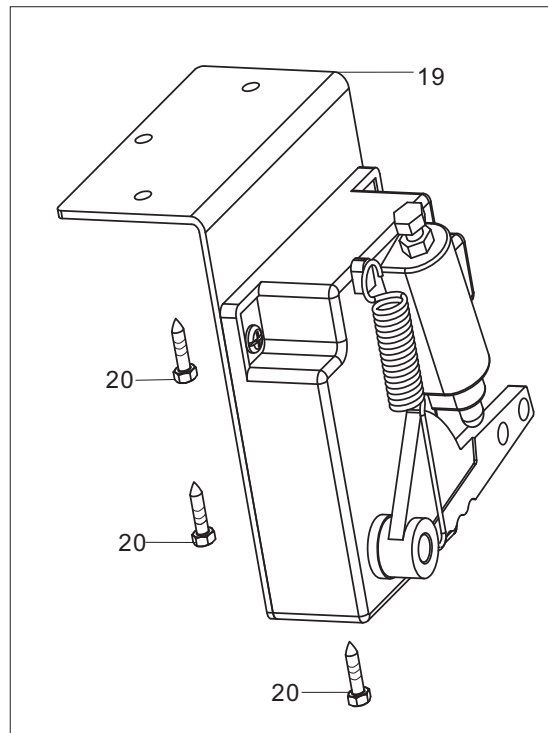
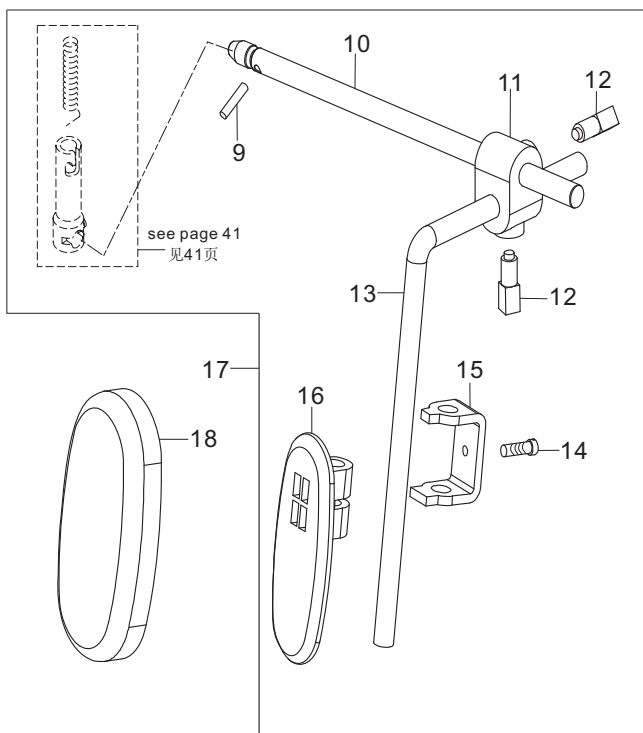
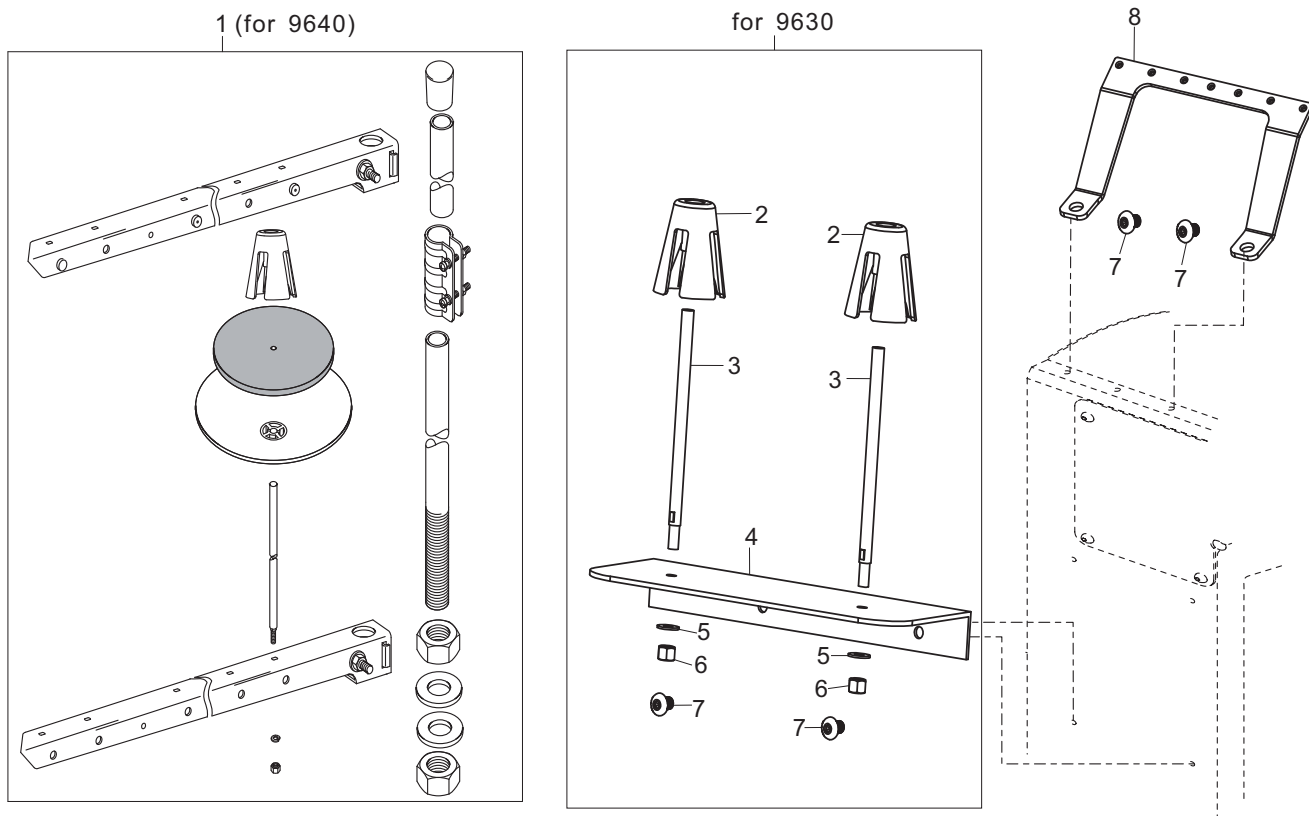

23.附件 (1) Accessories components (1)

序号 No.	件号 Part No.	名称	DESCRIPTION	数量 Qty
1	10006300	三线线架 (for 9640)	Three wire frame component	1
2	10004287	线盘塑料压块	Wire disc plastic pressing block	2
3	10041472	线架轴	Wire rack shaft	2
4	10041471	线盘支架	Wire coil bracket	1
5	10009207	垫片 $\Phi 5$	Washer $\Phi 5$	2
6	10002953	螺母 M5	Nut M5	2
7	10007096	螺钉 M5×10	Screw M5×10	2
8	10041470	过线架	Lead wire frame	1
9	10005193	销 4×18	Pin 4×18	1
10	10005045	操纵连杆	Control rod	1
11	10005199	操纵杆接头	Control rod joints	1
12	10005234	螺钉 M8×14	Screw M8×14	2
13	10005213	操纵杆	Control stick	1
14	10005421	螺钉 M5×13.3	Screw M5×13.3	1
15	10005273	膝控调节支架	Knee control adjusting bracket	1
16	10005115	膝控操纵架	Knee control frame	1
17	10004975	膝控组件	Knee control assembly	1
18	10005455	膝控软垫	Knee control pad	1
19	10048219	踏板	Pedal	1
20	10048223	踏板螺钉	Self tapping Screw	3

24. 附件(2)

Accessories components (2)

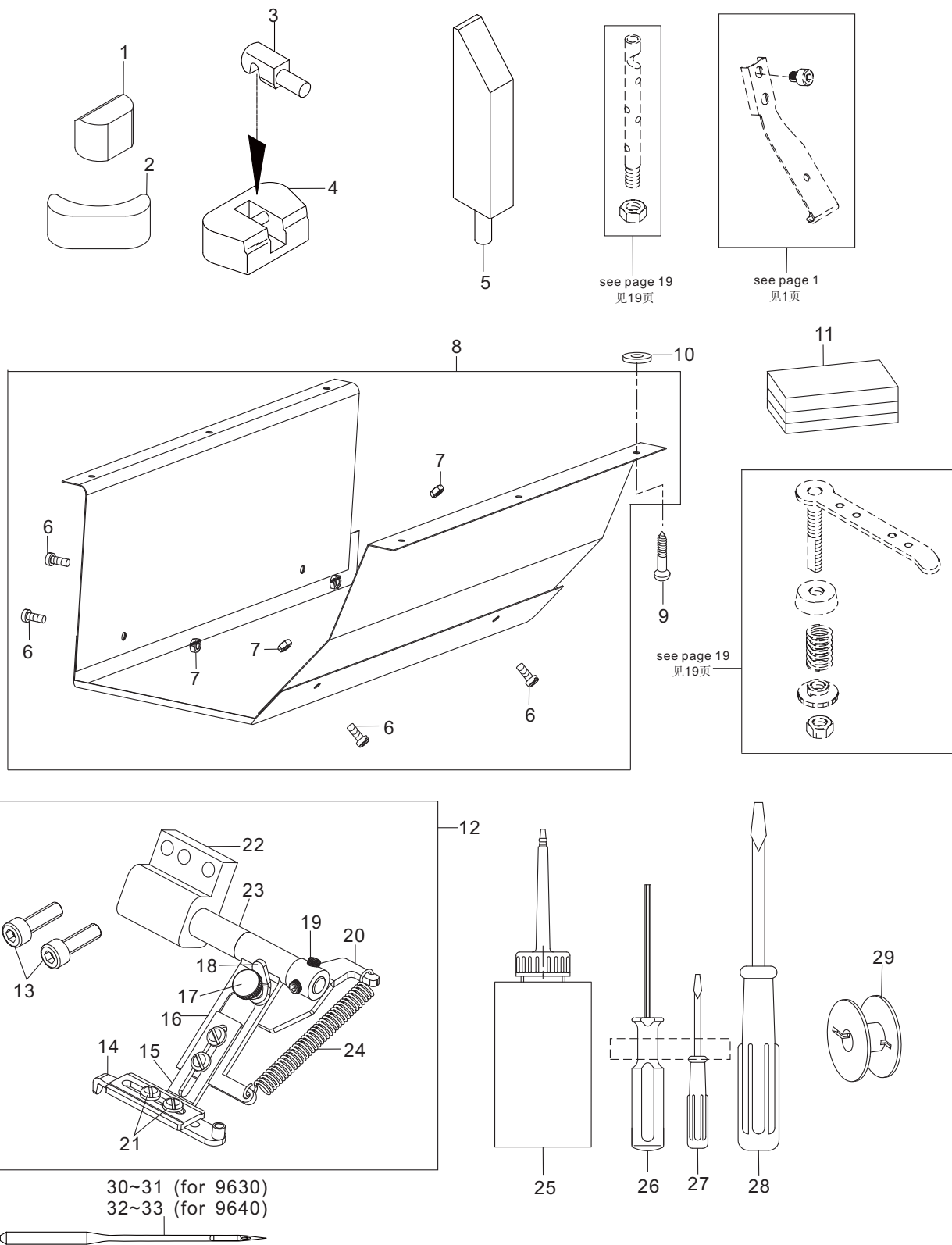

24.附件 (2) Accessories components (2)

序号 No.	件号 Part No.	名称	DESCRIPTION	数量 Qty
1	10005114	机头支座	Head support	2
2	10005248	机头座垫	Head cushion	2
3	10005374	机头铰链	head hinge	2
4	10005030	机头铰链座组件	Head hinge base assembly	2
5	10005484	木支架组件	Wood bracket assembly	1
6	10005299	螺钉 M4×5	Screw M4×5	4
7	10005297	螺母 M4	Nut M4	4
8	10056279	机头油盘	Head pan assembly	1
9	10008323	螺钉 ST4.2×20-C-H	Wood screw ST4.2×20-C-H	6
10	10005363	油盘油毡垫	Oil felt gasket	6
11	10007455	机头罩	Head cover	1
12	10041957	罗拉车靠边器	Pull device	1
13	10003164	螺钉 M5×16	Screw M5×16	2
14	10041972	靠边板组件	side plate assembly	1
15	10041959	调节板	Adjusting plate	1
16	10041961	导向板焊接件	Welding guide plate	1
17	10041958	滚花高头螺钉 M4×12	Screw M4×12	1
18	10041964	紧固扳手	Fastening wrench	1
19	10041976	螺钉 M6×5	Screw M6×5	1
20	10041968	调整焊接件	Welding adjustment	1
21	10003065	螺钉 M4×5	Screw M4×5	4
22	10041965	安装座	Mounting seat	1
23	10041966	轴	Shaft	1
24	10041971	拉簧	Drag spring	1
25	10005356	油壶	Oil pot	1
26	10009270	内六角扳手	Inner six angle wrench	1
27	10013185	小螺丝刀	Small screwdriver	1
28	10010995	中螺丝刀	Medium screwdriver	1
29	10005461	梭心	Bobbin	3
30	10006103	机针134PCL 90/14(for 9630-M)	Needle 134PCL 90/14 (for 9630-M)	4
31	10004103	机针134PCL120/19(for 9630-H)	Needle 134PCL120/19 (for 9630-H)	(4)
32	10001375	机针134-35 90/14(for 9640-M)	Needle 134-35 90/14 (for 9640-M)	4
33	10030202	机针134-35120/19(for 9640-H)	Needle 134-35120/19 (for 9640-H)	(4)

25. 可选配件 Optional fittings

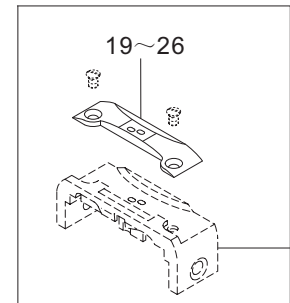
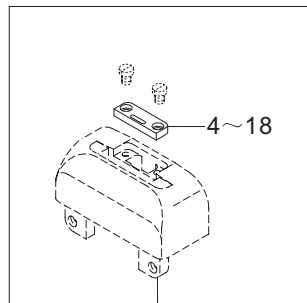
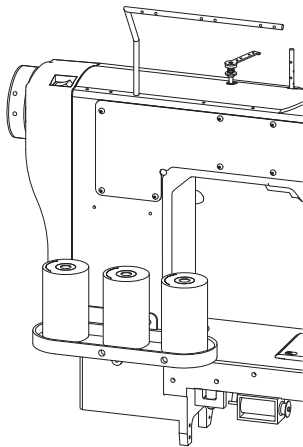
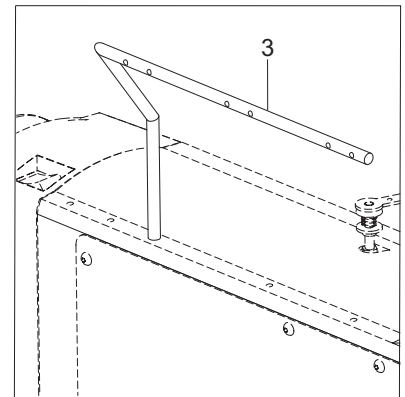
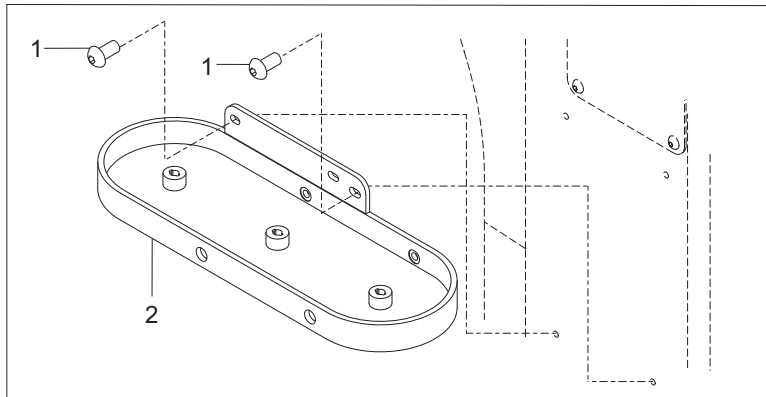

see page 37
见37页

see page 39
见39页

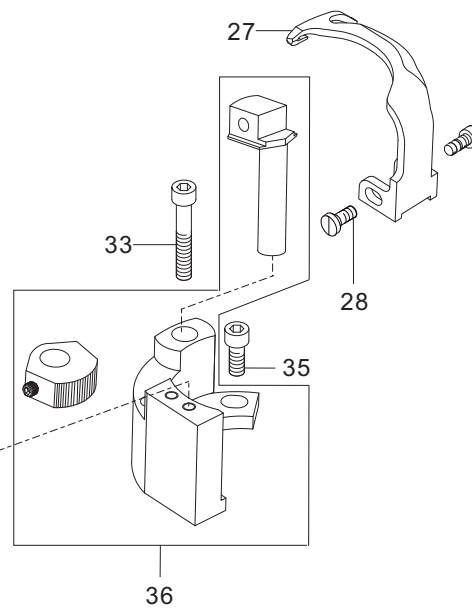
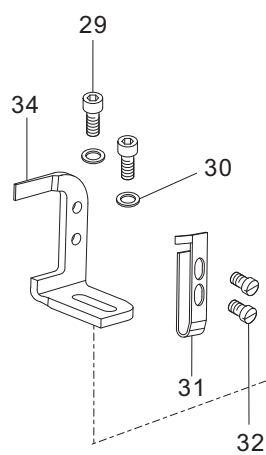

25.可选配件

Optional fittings

序号 No.	件号 Part No.	名称	DESCRIPTION	数量 Qty
1	10007096	螺钉 M5×10	Screw M5×10	1
2	10061819	线盘	Wire plate	1
3	10061818	过线架	Leading thread bracket	1
4	10053423	小针板M7.0	Small needle plate M7.0	(1)
5	10053424	小针板H7.0	Small needle plate H7.0	(1)
6	10055257	小针板M4.5	Small needle plate M4.5	(1)
7	10055258	小针板H4.5	Small needle plate H4.5	(1)
8	10057277	小针板M4.5	Small needle plate M4.5	(1)
9	10057278	小针板H4.5	Small needle plate H4.5	(1)
10	10050839	针板B7.0	Needle plate B7.0	(1)
11	10050840	针板C7.0	Needle plate C7.0	(1)
12	10054730	针板	Needle plate	(1)
13	10006299	针板-薄料	Needle plate thin	(1)
14	10001612	针板-厚料	Needle plate thick	(1)
15	10060559	单针小针板CH4.5	Single needle plate CH4.5	(1)
16	10063814	小针板CM4.5	Small needle plate CM4.5	(1)
17	10004104	针板-厚料	Needle plate thick	(1)
18	10059868	单针小针板H4.5	Single small needle plate	(1)
19	10004966	针板组件	Needle plate asm	1
20	10004102	针板组件-厚料	Needle plate asm thick	(1)
21	10001480	针板组件-厚料	Needle plate asm thick	(1)
22	10001478	针板组件-薄料	Needle plate asm thin	(1)
23	10039089	针板组件S(B4.5)	Needle plate asm (B4.5)	(1)
24	10039088	针板组件S(C4.5)	Needle plate asm (C4.5)	(1)
25	10050839	针板B7.0	Needle plate B7.0	(1)
26	10050840	针板C7.0	Needle plate C7.0	(1)
27	10001519	勾线板	Thread hook	1
28	10005547	螺钉 M3×6	Screw M3×6	2
29	10001513	螺钉 M3×6	Screw M3×6	2
30	10002068	垫圈	Washer	2
31	10001609	剪线刀固定板	Trimming knife fixation plate	1
32	10001512	螺钉 M2.5×3	Screw M2.5×3	2
33	10001608	螺钉 M4×25	Screw M4×25	1
34	10036966	剪线刀T	Trimming knife T	1
35	10005041	螺钉 M4×10	Screw M4×10	1
36	10001515	勾线板座	Thread hook bracket	1

